



HeartMate 3™

Left Ventricular Assist System

Instructions for Use

For Use with the HeartMate Touch™
Communication System



Abbott

HEARTMATE 3™ LEFT VENTRICULAR ASSIST SYSTEM

Instructions for Use

™ Indicates a trademark of the Abbott group of companies.

‡ Indicates a third party trademark, which is property of its respective owner.

Pat. <http://www.abbott.com/patents>

© 2020 Abbott. All Rights Reserved.

Bluetooth and Bluetooth logo are registered trademarks of Bluetooth SIG, Inc.

Preface - - - - - ix

1 Introduction - - - - - 1-1

Understanding Warnings and Cautions - - - - - 1-2

Overview - - - - - 1-3

Indications - - - - - 1-7

Contraindications - - - - - 1-7

Adverse Events - - - - - 1-8

Pre-Use Requirements - - - - - 1-8

Equipment Overview - - - - - 1-10

Required, Backup, and Optional Components and Equipment - - - - - 1-15

Principles of Operation - - - - - 1-17

Explanation of Parameters - - - - - 1-19

2 System Operations - - - - - 2-1

HeartMate 3™ Left Ventricular Assist Device Overview- - - - - 2-2

System Controller Overview- - - - - 2-8

The Backup System Controller- - - - - 2-45

3 Powering the System - - - - - 3-1

Power Overview - - - - - 3-2

Using the Power Module - - - - - 3-4

Using the Mobile Power Unit - - - - - 3-34

Using HeartMate 14 Volt Lithium-Ion Batteries - - - - - 3-51

Switching Power Sources - - - - - 3-66

Battery Charger Overview - - - - - 3-73

Charging HeartMate Batteries - - - - - 3-80

Calibrating HeartMate Batteries - - - - - 3-84

Using the Charger to Check Battery Power - - - - - 3-86

Care and Maintenance of the Battery Charger - - - - - 3-87

4 HeartMate Touch™ Communication System - - - - - 4-1

Overview - - - - - 4-2

Set Up the HeartMate Touch™ Communication System- - - - - 4-7

Connect the HeartMate Touch™ Wireless Adapter to the

HeartMate Touch Communication System	4-11
Interface Overview	4-20
HeartMate Touch™ App Views	4-21
Settings Panel	4-23
Alarms	4-40
Pump Parameters	4-50
Monitor View	4-55
Clinical View	4-56
Historical View	4-62

5 Surgical Procedures - - - - - 5-1

Surgical Considerations-	5-2
Equipment and Supplies Required for Implant	5-4
Preimplant Procedures-	5-7
Unpacking	5-10
Unpacking the Pump and Accessories Tray-	5-12
Unpacking the Sealed Outflow Graft	5-16
Preparing the Sealed Outflow Graft	5-17
Unpacking the System Controller	5-18
Unpacking the Modular Cable	5-19
Connecting and Initializing the Sterile System Controller to Non-Sterile Equipment	5-22
Preparing, Running, and Priming the Pump-	5-25
Preparing the Coring Knife	5-34
Implant Procedures	5-35
Postimplant Procedures	5-60
Postimplant Considerations	5-66
Device Explant	5-70

6 Patient Care and Management - - - - - 6-1

Postoperative Patient Care	6-2
Ongoing Patient Assessment and Care	6-6
Important Clinical Considerations for HeartMate 3™ Patients	6-9
Using the Shower Bag	6-13
Wearing and Carrying System Components	6-26
Preparing for Sleep	6-63
Ongoing System Assessment and Care-	6-64
Educating and Training Patients, Families, and Caregivers-	6-67

7	Alarms and Troubleshooting	7-1
7	Alarms and Troubleshooting	7-1
	System Controller Alarms	7-2
	HeartMate Touch™ App Alarms	7-25
	Handling Power Module Alarms	7-37
	Mobile Power Unit Alarms	7-40
	Using the Charger to Check Battery or Charger Status	7-42
	Guidelines for Power Cable Connectors	7-45
	What Not To Do: Driveline and Cables	7-46
8	Equipment Storage and Care	8-1
	Storage and Transport	8-2
	Cleaning and Maintenance	8-4
	Product Disposal	8-11
A	Summary of the Clinical Study	A-1
B	Technical Specifications	B-1
C	Safety Testing and Classification	C-1
D	HeartMate 3™ Product List	D-1
E	Symbols	E-1
F	Safety Checklists	F-1
G	Glossary	G-1

Preface

This manual contains information needed to properly and safely operate the HeartMate 3™ Left Ventricular Assist System. Users of the HeartMate 3 Left Ventricular Assist System should have a practical knowledge of the principles of mechanical circulatory support and should be aware of the physiological and psychological needs of a patient undergoing mechanical ventricular support. New users should read this document in its entirety, before system operation. For experienced practitioners, this manual may serve as a reference.

As with all prescription medical devices, clinical procedures should be conducted under the direction of the prescribing physician. The professional staff at Abbott regularly provides laboratory training and on-site, in-service programs.

INTRODUCTION

This section provides an introduction to the HeartMate 3™ Left Ventricular Assist System.

Understanding Warnings and Cautions - - - - - 1-2

Overview - - - - - 1-3

Indications - - - - - 1-7

Contraindications - - - - - 1-7

Adverse Events - - - - - 1-8

Pre-Use Requirements - - - - - 1-8

Equipment Overview - - - - - 1-10

Required, Backup, and Optional Components and Equipment - - - 1-15

Principles of Operation - - - - - 1-17

Explanation of Parameters - - - - - 1-19

Understanding Warnings and Cautions

Warnings refer to actions or hazardous conditions that could cause serious injury or death if not avoided. Ignoring a warning can cause sudden and serious injury, life-threatening harm, or death for the user or patient.

Cautions refer to actions or potentially unsafe conditions that may cause injury, damage the equipment, or affect how the system works. Ignoring a caution can cause patient or user injury, or result in equipment failure or sub-optimal system operation. Although important for maximum safety and optimal system function, usually cautions do not refer to life-threatening risks.

In this manual, warnings and cautions that are relevant to a specific procedure or piece of equipment appear at the start of each applicable section.

WARNING !

Warnings appear in the manual in this format.

CAUTION !

Cautions appear in the manual in this format.

Overview

The HeartMate 3™ Left Ventricular Assist System (LVAS) is a set of equipment and materials that together comprise a medical device designed to provide therapeutic benefit to those affected with advanced heart failure. In service, the LVAS assumes some or all of the workload of the left ventricle, thereby restoring the patient's systemic perfusion while palliating the underlying pathology. The LVAS features a Left Ventricular Assist Device (LVAD), a blood pump intended for long-term implantation in such patients, an extracorporeal Controller, plus all of the features, controls, attachments, interfaces, power sources, supporting equipment, labeling, and tools required to achieve the desired therapeutic benefit. The HeartMate 3 Left Ventricular Assist System is intended for use inside or outside the hospital, or for transportation of LVAD patients via ground ambulance, airplane, or helicopter.

The LVAS may be used in any of two configurations. First, line power may be utilized through the Power Module or the Mobile Power Unit™ to run the LVAD indefinitely, convenient for sedentary or sleeping periods. Second, portable Battery power may be utilized for limited periods, convenient for active periods. Due to the bifurcation of the Patient Cable, switching among these configurations or from one set of Batteries to another (as when one set has been depleted and a fully charged set is available) may be accomplished without interrupting LVAS function. Whenever the Power Module is used, a HeartMate Touch™ Communication System may also be used as a means of viewing operating conditions, changing operating parameters, and manipulating stored data.

A set of user manuals provides instructions at various levels appropriate for users to explain how to use the equipment and how to interpret and respond to alarms. The LVAS is packaged for safe transport and effective use in an operating room under sterile conditions.

The HeartMate 3 LVAD is part of the LVAS. See **Figure 1.1**.



Figure 1.1 HeartMate 3™ LVAS During Battery-Powered Operation

The LVAD is a blood pump intended for implantation in the thorax of patients affected with advanced heart failure. The LVAD contains an Inflow Cannula, a Pump Cover, a Lower Housing, a Screw Ring to attach the Pump Cover to the Lower Housing, a Motor, the Outflow Graft, and a Pump Cable.

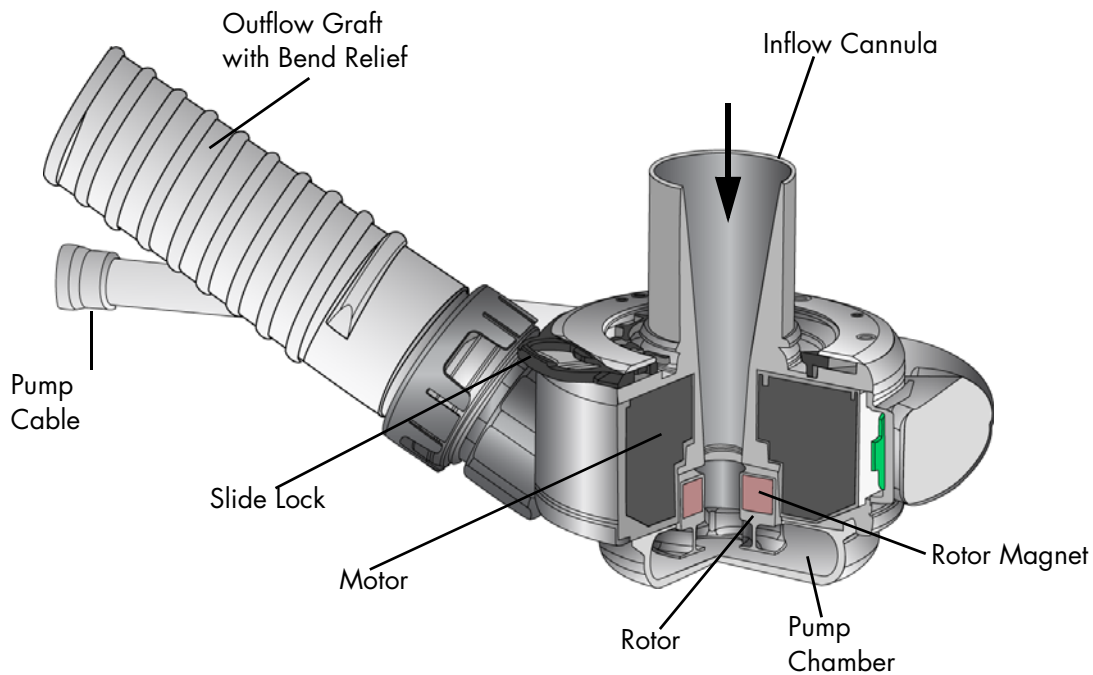

Figure 1.2 Left Ventricular Assist Device Components

The LVAD is surgically connected to the patient's circulatory system via an Inflow Cannula placed into the left ventricular apex, and an Outflow Graft anastomosed to the ascending aorta. The LVAD is a centrifugal pump: ventricular blood is drawn into the Inflow Cannula along a central axis and is expelled at right angles by and between the impeller blades of a Rotor rotating about the central axis. The fluid thus angularly accelerated collects and travels around a volute before it is diffused to a desired pressure and flow rate by being directed tangentially into the Outflow Graft.

The Rotor is fully supported by magnetic levitation, obviating mechanical or fluid bearings and essentially eliminating Rotor mechanical wear as a reliability factor. Both drive (i.e. rotation) and levitation of the Rotor is accomplished using a single Stator comprising iron pole pieces, a back-iron, copper coils, and position sensors. By measuring the position of a permanent magnet in the Rotor and appropriately controlling the current in the drive and levitation coils, the radial position and rotational speed of the Rotor is actively controlled. Because of the permanent magnet's attraction to the iron pole pieces, the rotor passively resists excursion in the axial direction, whether such excursion is translation or tilting.

The electronics and software necessary to control motor drive and levitation are integrated into the Lower Housing with the Stator, and all of these plus the Rotor are regarded to comprise the Motor.

The Inflow Cannula is a cylindrical conduit with external size and features similar to those of the HeartMate II™. It is rigidly affixed to the Pump Cover. During the implantation procedure, a Coring Tool is used to resect a plug of myocardium at the left ventricular apex to allow insertion of the Inflow Cannula into the left ventricle. An Apical Attachment Cuff is sewn to the epicardium, and a slide lock is used to secure the Inflow Cannula and establish hemostasis.

The Outflow Graft assembly consists of a sealed woven polyester graft and the hardware necessary to attach the graft to the Pump Cover. The distal end of the graft is designed to be cut to desired length and sutured to the ascending aorta by an end-to-side anastomosis (only the graft is to be cut, not the bend relief). A reinforced tube serves as a bend relief around the Outflow Graft to prevent kinking and abrasion. The bend relief can be attached or removed and reattached during the implantation procedure. If necessary, the Outflow Graft may be detached from the Pump Cover, permitting pump replacement without re-anastomosis.

A Pump Cable is permanently attached to the Lower Housing to establish electrical connection with the enclosed Motor via a hermetically sealed feed-through. This Pump Cable is tunneled through subdermal abdominal tissue via a Tunneling Tool and is exteriorized through a skin wound prepared with a Skin Coring Punch at a location deemed optimal for the patient and his equipment. The Pump Cable extends only a few inches through this site. It is extended with a Modular Cable, which connects the Pump (through the Pump Cable) to a System Controller and is readily replaceable without surgery if necessary. The Pump Cable and Modular Cable, once connected, comprise the Driveline. The Driveline contains duplicate sets of three conductors: two for power and ground, and a third for communication.

The HeartMate 3 System Controller is also part of the Left Ventricular Assist System (LVAS). The System Controller is an extracorporeal interface device that receives power from the Power Module, the Mobile Power Unit, or portable Batteries, and appropriately delivers that power to the LVAD. It is the primary user interface and has several important functions:

- Operating condition display,
- Source of audible and visible alarms,
- Communication link for transferring event/period log and alarm information, and
- Battery backup in the case of full power disconnection.

WARNING !

- A thorough understanding of the technical principles, clinical applications, and risks associated with left ventricular support is necessary before using the HeartMate 3 Left Ventricular Assist System. Read this entire manual before attempting implantation of the Left Ventricular Assist Device or before caring for HeartMate 3 patients. Completion of Abbott HeartMate 3 Surgical Training Program is also required prior to use.
- Understanding the operating and safety aspects of the HeartMate 3 Left Ventricular Assist System is critical for safe and successful use.
- All users, including clinicians, patients, and caregivers, must be trained on system operation and safety before use.
- All users, including clinicians, patients, and caregivers, must be trained on any HeartMate 3 power accessories (Mobile Power Unit, Battery Charger, or HeartMate 14 Volt Lithium-Ion batteries) before use.
- Do not use the HeartMate 3 Left Ventricular Assist Device in pregnant women or in women likely to become pregnant. A growing fetus may dislodge the pump, which may result in device failure, catastrophic bleeding, or death. Instruct women of childbearing age to use reliable contraception if sexually active. Blood thinners have been associated with birth defects. Anticoagulation regimens are contraindicated during pregnancy.
- Do not modify this equipment without authorization from Abbott. The use of unauthorized replacement parts may affect the electromagnetic compatibility of the Mobile Power Unit with other devices. Potential interference may occur between the Mobile Power Unit and other devices.
- Certain parts of the HeartMate 3 Left Ventricular Assist System are not compatible with other HeartMate systems. Only use HeartMate 3 parts with the HeartMate 3 system.
- The HeartMate 3 pump may cause interference with implantable cardiac defibrillators (ICD). If electromagnetic interference occurs it may lead to inappropriate ICD therapy. The occurrence of electromagnetic interference with ICD sensing may require adjustment of device sensitivity and/or repositioning the lead.

CAUTION !

- Clinical procedures (including LVAS settings) should be conducted under the direction of the prescribing physician (Authorized Personnel) only.
- Do not try to repair any of the HeartMate 3 system components. If components need service, contact appropriate personnel.
- Notify appropriate personnel if there is a change in how the pump works, sounds, or feels.
- Counsel the patient to avoid contact sports and jumping activities while implanted with the pump. Contact sports or jumping can cause bleeding or damage the pump.
- Care should be taken when small children or pets are present. There is a potential for strangulation from the system's cables.
- If HeartMate 3 patients are approved for showering, they must always use the Shower Bag. When installed properly, the Shower Bag protects external system components from water or moisture. If external system components have contact with water or moisture, the pump may stop.

Indications

The HeartMate 3 Left Ventricular Assist System is indicated for providing short- and long-term mechanical circulatory support (e.g., as bridge to transplant or myocardial recovery, or destination therapy) in patients with advanced refractory left ventricular heart failure.

Contraindications

The HeartMate 3 Left Ventricular Assist System is contraindicated for patients who cannot tolerate, or who are allergic to, anticoagulation therapy.

Adverse Events

Adverse events that may be associated with the use of the HeartMate 3™ Left Ventricular Assist System are listed below. Adverse events are listed in anticipated decreasing order of frequency, except for death, which appears first as it is a non-reversible complication:

- Death
- Bleeding
- Cardiac Arrhythmia
- Localized Infection
- Device Malfunctions
- Right Heart Failure
- Respiratory Failure
- Driveline Infection
- Sepsis
- Renal Dysfunction
- Other Neurological Event (not stroke-related)
- Stroke
- Hypertension
- Psychiatric Episode
- Venous Thromboembolism
- Hepatic Dysfunction
- Arterial Non-Central Nervous System (CNS) Thromboembolism
- Pericardial Fluid Collection
- Pump Pocket or Pseudo Pocket Infection
- Myocardial Infarction
- Wound Dehiscence
- Hemolysis (not associated with suspected device thrombosis)
- Pump Thrombosis

Pre-Use Requirements

A thorough understanding of the technical principles, clinical applications, and risks associated with left ventricular support is required before using the HeartMate 3™ Left Ventricular Assist System.

It is suggested that patients possess a minimum 5th grade educational level and shall be versed in basic computer literacy (i.e., Microsoft® Windows® and Office software).

This manual contains important warnings, cautions, and instructions for use. Read this entire manual before implanting a HeartMate 3 Left Ventricular Assist Device or before caring for HeartMate 3 patients. Completion of Abbott HeartMate 3 Surgical Training Program is also required.

If you have questions after reading this manual, please contact Abbott for assistance. See *Abbott contact information* on the *Back Cover* of this manual.

Equipment Overview

The table below introduces the main parts of the system, along with useful accessories. All of these items are described in more detail later in this manual.

Left Ventricular Assist Device



The HeartMate 3™ Left Ventricular Assist Device (frequently called the “pump”) is implanted in the chest below the heart. One end is inserted into the apex of the left ventricle; the other end connects to the ascending aorta. The pump diverts blood from the weakened left ventricle and pumps it to the aorta.

For more information, see page 1-17.

System Controller



The System Controller is a small computer that controls and monitors system operation. The System Controller uses lights, sounds, and on-screen messages to communicate with users about operating status and alarm conditions. A Driveline, which passes through the patient’s abdomen, connects the implanted pump to the System Controller.

For more information, see page 2-8.

14 Volt Lithium-Ion Batteries & 14 Volt Battery Clips



Two HeartMate 14 Volt Lithium-Ion batteries are used to power the system during battery-powered operation, such as when AC electricity is not wanted or unavailable. Batteries are used in pairs and are inserted into a 14 Volt battery clip. Both batteries are discharged together (not one, then the other). Two power cables are required to transfer battery power to the System Controller. When fully charged, a pair of HeartMate 14 Volt Lithium-Ion batteries can power the system for up to 10–17 hours, depending on the activity level of the patient.

For more information, see page 3-51.

Table 1.1 HeartMate 3™ System Components

Modular Cable



The Driveline consists of two cables: the Pump Cable and the Modular Cable. One end of the Pump Cable connects to the pump implanted in the patient's abdomen. The other end of that cable exits the patient's body. One end of the Modular Cable is connected to the Pump Cable and the other end connects to the System Controller.

Power Module



The Power Module is for clinical use. The Power Module plugs into an AC to provide power to the HeartMate 3 system. The Power Module is used when the patient is indoors, stationary, or sleeping. A sleeping patient may not hear low battery power alarms. The System Controller and the Power Module are connected through the Power Module patient cable. The cable transfers power from the Power Module to the System Controller.

For more information, see page 3-4.

Power Module Patient Cable



The Power Module patient cable connects the Power Module to the System Controller. Connections are made between white-to-white and black-to-black connectors.

For more information, see page 3-15.

Mobile Power Unit



The Mobile Power Unit™ is for home or clinical use when the patient does not require monitoring using the HeartMate Touch™ Communication System. The Mobile Power Unit is used when the patient is indoors, stationary, or sleeping, as a sleeping patient may not hear low battery power alarms. The System Controller and the Mobile Power Unit are connected through the Mobile Power Unit patient cable. The cable transfers power from the Mobile Power Unit to the System Controller.

For more information, see page 3-34.

HeartMate Touch Communication System



The HeartMate Touch Communication System provides clinicians with the ability to wirelessly monitor a patient's HeartMate system, program system parameters such as pump speed, assess and track alarm conditions, and view and save performance data. Its use during Left Ventricular Assist Device implantation is required.

For more information, see page 4-2.

Table 1.1 HeartMate 3™ System Components (Continued)

Battery Charger



The Battery Charger calibrates, charges, and tests the HeartMate 14 Volt Lithium-Ion batteries that are used to power the system during battery-powered operation.

For more information, see page 3-73.

Shower Bag



The Shower Bag is used to protect external system components from water or moisture—outside in heavy rain or snow, and always for every shower. HeartMate 3 patients may be allowed to shower when the Driveline exit site has healed and with permission from their doctor. If external system components have contact with water or moisture, the system may fail to operate properly or the patient may get a serious electric shock.

For more information, see page 6-13.

System Controller Neck Strap



The System Controller Neck Strap attaches to the System Controller and is used to wear the System Controller around the neck or across the body.

For more information, see page 6-28.

Belt Attachment



The belt attachment provides another way to wear the System Controller.

For more information, see page 6-33.

Table 1.1 HeartMate 3™ System Components (Continued)

Consolidated Bag



The Consolidated Bag is a convenient way to carry two HeartMate 14 Volt Lithium-Ion batteries and attached battery clips during battery-powered operation.

For more information, see page 6-37.

Battery Holster



The Battery Holster provides a convenient way to wear two HeartMate 14 Volt Lithium-Ion batteries and attached battery clips.

For more information, see page 6-46.

Holster Vest



The Holster Vest provides another way to wear the HeartMate 14 Volt Lithium-Ion batteries and attached battery clips.

For more information, see page 6-52.

Table 1.1 HeartMate 3™ System Components (Continued)

Travel Bag



The Travel Bag provides a convenient way to carry and transport the backup System Controller and spare batteries.

For more information, see page 6-61.

Protection Bag



The Protection Bag stores and protects the backup System Controller.

For more information, see page 6-60.

ICU Cover



The disposable, non-sterile, single-patient use ICU Cover is a location management accessory to secure the System Controller to a visible location using the provided Clip.

For more information, see the *ICU Cover Instructions for Use* shipped with the ICU Cover.

Table 1.1 HeartMate 3™ System Components (Continued)

Required, Backup, and Optional Components and Equipment

The HeartMate 3™ Left Ventricular Assist System is designed for use both inside and outside of the hospital. Specific system components and equipment may be required for each setting. Components and equipment that are required for implant and ICU transfer are listed in **Table 1.2**.

Components Required for Implantation and ICU Transfer	Primary	Backup
HeartMate 3 Implant Kit*	Required	Required
System Controller with 11 Volt Lithium-Ion Backup Battery	Required	Required
Power Module with patient cable	Required	Required
Tablet for use with the HeartMate Touch App and HeartMate Touch Wireless Adapter	Required	Required
One set of 4 rechargeable HeartMate 14 Volt Lithium-Ion batteries	Required	Not required
One set of 2 HeartMate 14 Volt battery clips and battery clip cables	Required	Not required
Battery Charger	Required	Not required
HeartMate 3 Tunneling Lance and Handle**	Required	
Apical coring knife**	Optional	
Skin coring punch (6 mm)*	Optional	
Apical cuff**	Optional	
Outflow Graft Thread protectors**	Optional	
Modular Cable Cap	Optional	

Table 1.2 Components for Implant

* Some "Optional" items are included in the HeartMate 3 Implant Kit.

** Also available separately.

Components and equipment that are required for a discharged patient are listed in

Table 1.3. Patients discharged to a lower care facility or to their homes must be trained in device use, maintenance, and troubleshooting. In addition, device malfunction may necessitate emergency treatment. Therefore, patients should not be more than two hours from a healthcare facility that has trained personnel who are capable of treating a HeartMate 3 patient.

Components for a Discharged Patient	Primary	Backup
Implanted HeartMate 3 Left Ventricular Assist Device	Required	n/a
System Controller with 11 Volt Lithium-Ion backup battery	Required	Required
Mobile Power Unit	Required	Not Required
One set of 4 rechargeable HeartMate 14 Volt Lithium-Ion batteries	Required	Required
One set of 2 HeartMate 14 Volt battery clips	Required	Not Required
Battery Charger	Required	Not Required
One set of wear & carry accessories, including: Shower Bag, Protection Bag for backup System Controller, holster vest, belt attachment accessory, and System Controller Neck Strap	Required	Not Required
HeartMate 3 Patient Handbook	Required	Not Required

Table 1.3 Components for Discharged Patients

CAUTION !

Confirm that the patient's backup System Controller has had the 11 Volt Lithium-Ion backup battery installed and the time and date have been set.

WARNING !

A backup System Controller and charged batteries must remain with the patient at all times for use in an emergency. Patient and caregiver training must address this crucial need.

Principles of Operation

The HeartMate 3™ LVAD is a centrifugal pump that produces flow in the patient's circulatory system by angularly accelerating and expelling blood that enters it. From a clinical viewpoint, this mechanical pump works in concert with the native heart to which it is attached. It is a parallel arrangement - ventricular blood may flow either through the LVAD or the aortic valve to reach the aorta - the proportion of which depends greatly upon the degree of the patient's cardiac function and the set-speed of the LVAD.

As for any continuous flow pump (axial, centrifugal, or mixed), the volume flow rate through the pump is directly related to the pressure across the pump and inversely related to the resistance. Clinically, the volume flow rate through the Pump is the difference between aortic and left ventricular pressure, and systemic vascular resistance. This relationship can be characterized at any rotor speed, and the family of curves derived in steady-state at different speeds is commonly termed "H-Q curves", or the pressure head (H) - volume flow rate (Q) relationship. HeartMate 3 H-Q curves are shown in **Figure 1.3**.

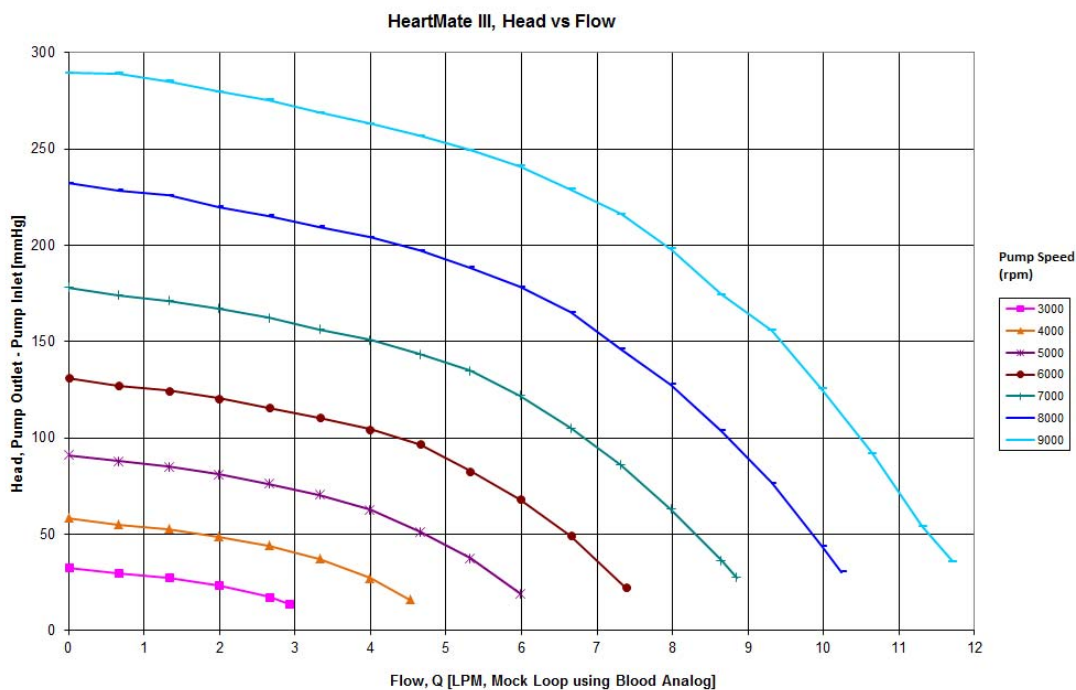

Figure 1.3 Pressure Head-Flow (H-Q) Relationship

Similarly, there is a characteristic relationship between pump power and volume flow rate. Total power consumption includes hydraulic power (useful blood pressure and flow), viscous losses, electrical resistance losses, and others. The relationship between hydraulic power and volume flow

rate is always direct, but the various losses have a multitude of dependencies that make inflections in the relationship possible.

In general, if the speed is set optimally, LVAD flow will be unidirectional towards the aorta and much greater than cardiac output, which may be minimal or zero if the presence of the LVAD keeps the aortic pressure above the ventricular pressure even during systole. If the LVAD speed is set *too high*, the inflow pressure may fall to the extent that it attempts to recruit blood from the left ventricle, left atrium, and pulmonary vasculature that simply is not there, resulting in collapse of the left ventricle and potential arrhythmia. The HeartMate 3 LVAS employs a feature called Pulsatility Index (PI) Detection to recognize and avert this condition. When the degree of pulsatility measured in the electrical current waveform has fallen below a preset value, the system regards this as a risk of ventricular suction and quickly lowers the rotor speed to a preset, programmable Low Speed Limit, then immediately but gradually returns the rotor to its original speed. The HeartMate 3 has an intrinsic limit somewhat above 9000rpm. The system accordingly precludes setting the speed above 9000rpm. Conversely, if the LVAD speed is set too low, support for the failing heart may be insufficient. The HeartMate 3 LVAS uses the same Low Speed Limit mentioned above to limit how low the speed may be set. This is to avoid profound retrograde flow (aorto-ventricular shunt). The Low Speed Limit is settable within a range to accommodate customization for a variety of patients.

The HeartMate 3 employs a feature called Artificial Pulse that adds an element to the discussion about rotor speed (**Figure 1.4**). Although the clinician will set only a single speed, ω_c in **Figure 1.4**, the rotor speed will periodically depart from this value in order to contribute a flow disruption that in some ways mimics native cardiac contractility. This artificial pulse “beats” 30 times per minute, asynchronously with the heart. The Artificial Pulse mode is indicated on the System Controller by the use of a (▲) symbol.

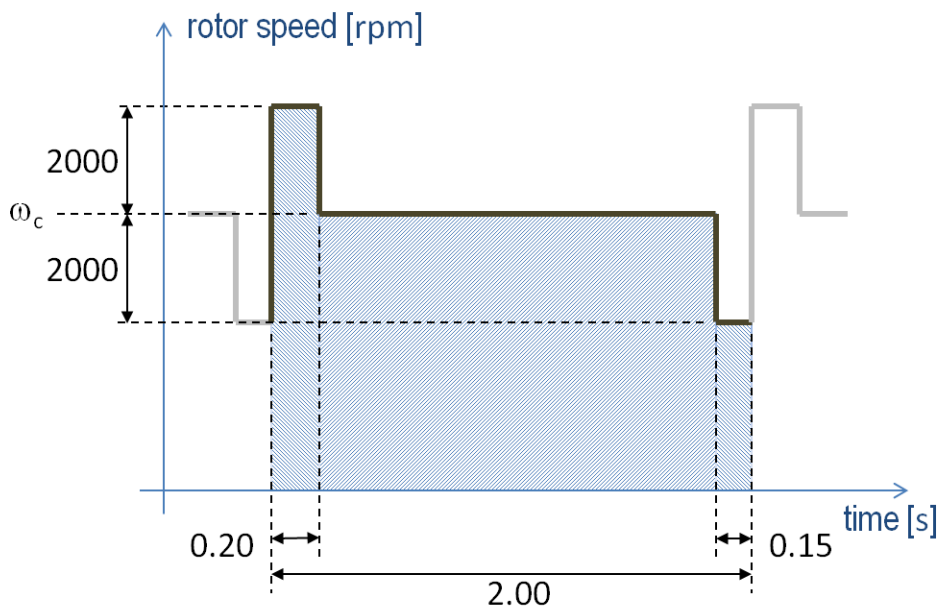

Figure 1.4 Artificial Pulse

Explanation of Parameters

Speed

The HeartMate 3™ Left Ventricular Assist Device operates at a fixed speed (see *Optimal Fixed Speed* on page 4-25) determined by the physician during a speed ramp study.

Note: The term “fixed speed” is a speed fixed, or set, by the clinician, i.e., ω_c in **Figure 1.4**. This should not be confused with the concept of a constant speed mode, as opposed to an artificial pulse mode. Either mode requires a fixed speed, set by the clinician.

A pre-programmed artificially induced pulse is intermittently generated, changing pump speed. The “low speed limit” for the device is the lowest speed at which it allowed to operate.

During a suction event, device speed drops to the “low speed limit” and then ramps up to the fixed speed unless another Pulsatility Index (PI) event is detected. If another PI event is detected, the device drops to the “low speed limit” again and then ramps back up. This cycle repeats as long as PI events are detected. Large changes in speed may indicate an abnormal condition that should be evaluated for cause.

Power

Device power is a direct measurement of pump motor voltage and current. Changes in pump speed, flow, or physiological demand can affect pump power. Gradual power increases (over hours or days) may signal thrombus deposits inside the pump, aortic or insufficiency. Gradual power decreases may indicate an obstruction of flow and should be evaluated. Depending on the speed of the pump, power values greater than 10 to 12 watts (W) also can indicate the presence of a thrombus. Abrupt changes in power should be evaluated for cause.

Flow

Device flow and power generally retain a linear relationship at a given speed. However, while power is directly measured by the System Controller, the reported flow is estimated, based on power. Since the flow displayed on the System Controller is a calculated value, it somewhat underestimates actual flow at high flows.

Any increase in power not related to increased flow (such as thrombus) causes erroneously high flow readings. Conversely, an occlusion of the flow path decreases flow and causes a corresponding decrease in power. In either situation, pump output should be assessed.

Pulsatility Index (PI)

When the left ventricle contracts, the increase in ventricular pressure causes an increase in pump flow during cardiac systole. The magnitude of these flow pulses are measured and averaged over 15-second intervals to produce a "Pulsatility Index" (occasionally shortened to "PI" for on-screen messages).

The PI calculation represents cardiac pulsatility. PI values typically range from 1 to 10. In general, the magnitude of the PI value is related to the amount of assistance provided by the pump. Higher values indicate more ventricular filling and higher pulsatility (ie, the pump is providing less support to the left ventricle). Lower values indicate less ventricular filling and lower pulsatility (ie, the pump is providing greater support and further unloading the ventricle).

PI values should be routinely monitored and should not vary significantly during resting conditions. Under otherwise stable conditions, a significant drop in value may indicate a decrease in circulating blood volume. Pulsatility Index values near or above 10 may indicate potential problems. For PI values near 10 or above, please contact Abbott. For Abbott contact information, see the *Back Cover* of this manual.

IMPORTANT! One single pump parameter is not a surrogate for monitoring the overall clinical status of the patient. Any change in parameters should be evaluated with all clinical considerations taken into account.

SYSTEM OPERATIONS

This section describes the primary system operations of the HeartMate 3™ Left Ventricular Assist System.

HeartMate 3™ Left Ventricular Assist Device Overview	- - - - -	2-2
System Controller Overview	- - - - -	2-8
The Backup System Controller	- - - - -	2-45

HeartMate 3™ Left Ventricular Assist Device Overview

The HeartMate 3™ Left Ventricular Assist Device (**Figure 2.1**) is a centrifugal flow rotary heart pump that is connected in parallel to the native circulation. The inflow cannula of the Left Ventricular Assist Device attaches to the apex of the left ventricle. Its sealed outflow graft connects to the ascending aorta (**Figure 2.2**). Frequently, the HeartMate 3 Left Ventricular Assist Device is called the “pump.”



Figure 2.1 HeartMate 3™ Left Ventricular Assist Device

Function

The LVAD uses a rotary blood pump to generate flow and assist the left ventricle. It is a centrifugally-configured device so that the paths of the entering and exiting flow stream are perpendicular to the pump's axis. The device has only one moving part, the rotor assembly, which is fully (i.e., actively) magnetically levitated within the flow stream. The pump is driven by an external power source via a Driveline.

The pump operates in parallel with the heart, such that either can supply blood to the aorta. The LVAD can generate a blood flow up to 10 liters per minute (lpm). Blood enters the pump from the left ventricle through an Inflow Cannula. Blades on the spinning rotor move the blood through the pump to an Outflow Cannula and ultimately to the native circulation.

Implant Location

The HeartMate 3™ Left Ventricular Assist Device is implanted in the chest (see **Figure 2.2**). For more information, see *Implant Procedures* on page 5-35.

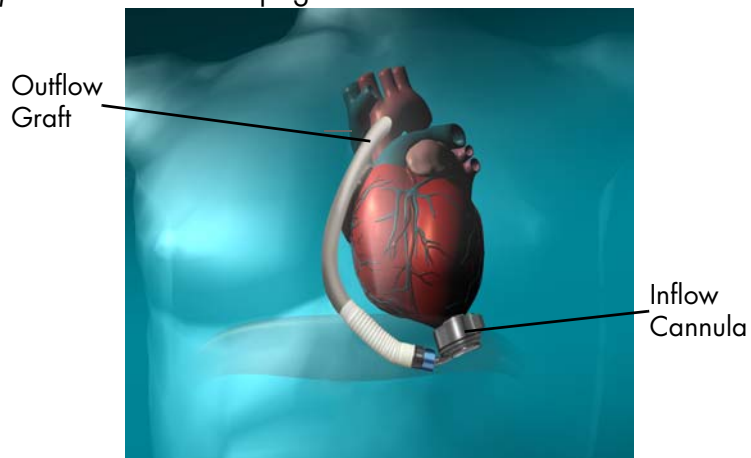

Figure 2.2 HeartMate 3™ Implant Configuration

The HeartMate 3 LVAD is part of the Left Ventricular Assist System (**Figure 2.3**).

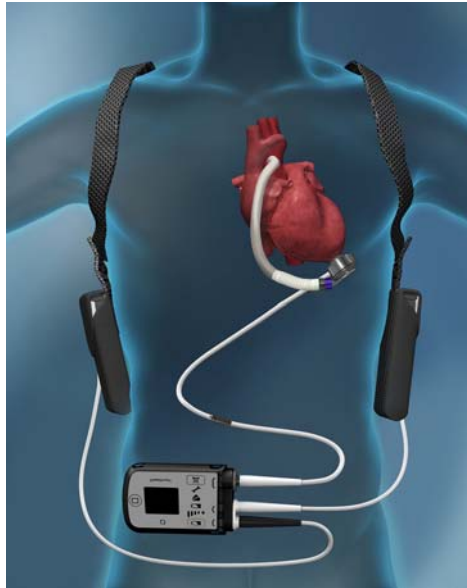

Figure 2.3 HeartMate 3™ LVAS During Battery-Powered Operation

Driveline

The Driveline consists of two cables: the Pump Cable, that extends from the Left Ventricular Assist Device through the skin, and the Modular Cable which connects the Pump Cable to the System Controller. The Driveline contains six wires—three primary wires and three backup wires—that power the Pump Motor and facilitates communication with the System Controller.

To reduce infection, the Driveline is covered with woven polyester, which encourages tissue ingrowth at the skin line. Over time, tissue bonds to the textured material and anchors the external surface of the Driveline to the surrounding tissue. After emerging from the body, the Driveline has a Modular Connector that joins the Pump Cable to the Modular Cable. The Modular Cable then has an electric connector that attaches to the System Controller.

Experience with other LVADs has shown that wear and fatigue of the Driveline may result in damage that can interrupt device function. Such damage may require another operation to replace the pump, or result in death. For information about caring for the Driveline, see *Care of the Driveline* on page 8-5.

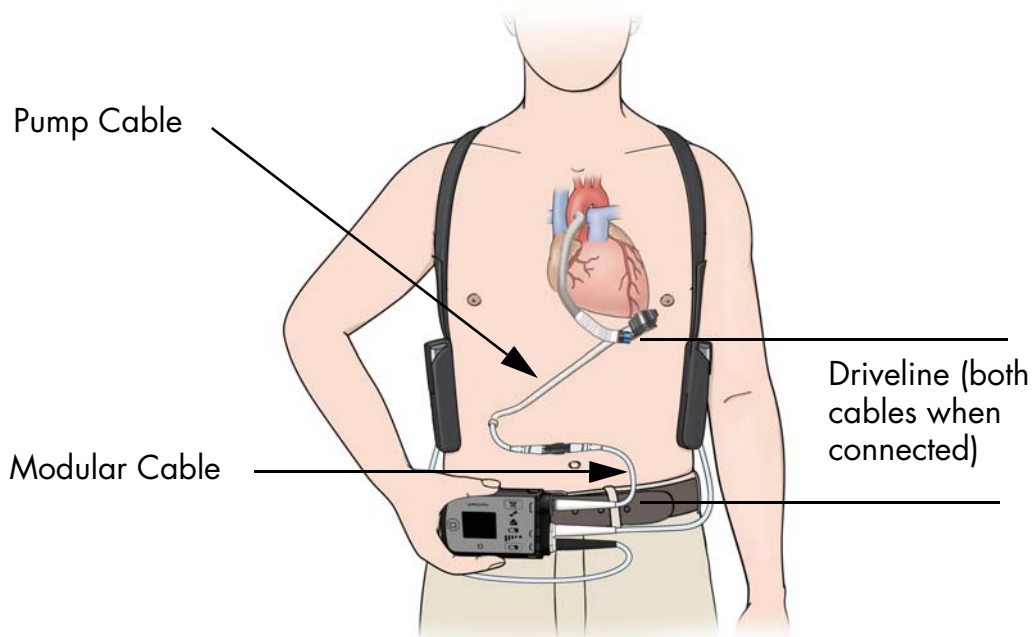

Figure 2.4 Driveline

Driveline damage due to wear and fatigue may occur in both the externalized (Modular Cable) and implanted portions (Pump Cable) of the lead. Damage to the conductors within the Driveline may or may not be preceded by visible damage to the outer layer of the Driveline.

Driveline damage may be evidenced by the following:

- A Driveline Power Fault, Driveline Comm Fault, or Communication Fault alarm on the System Controller.
- Transient alarms due to short or open circuits, often associated with movement of the patient or the lead.
- Fluid leakage from the external portion of the Pump Cable.
- Cessation of pumping.

WARNING !

If the Driveline or Driveline connector appears damaged, contact Abbott for assistance. Refer to the *Back Cover* of this manual for Abbott contact information.

X-ray images and System Controller log files are useful to assess the extent and location of the damage. If the Driveline or Driveline conductors are damaged internal to the patient's body, the pump should be replaced as soon as possible. If it has been determined that the damage has been detected in the Modular Cable, it can be replaced. Please refer to *Replacing the Modular Cable* on page 2-62 for the procedure for exchanging the Modular Cable.

Powering the Pump Motor

The Left Ventricular Assist Device Motor is powered through the System Controller by one of three sources: the Power Module or the Mobile Power Unit that is connected to an AC electrical outlet (see *Using the Power Module* on page 3-4), or two HeartMate 14 Volt Lithium-Ion Direct Current (DC) Batteries (see *Using HeartMate 14 Volt Lithium-Ion Batteries* on page 3-51).

Note: The Backup System Controller is charged every six months.

Acceptable Operating Conditions

For safe and optimal use of HeartMate system components, follow the operating guidelines listed here. Operating system components outside of the environmental parameters listed below may affect device operation.

Equipment	Acceptable Temperature Range °F (°C)	Relative Humidity	Air Pressure mm Hg (hPA)
Power Module	32°F to 104°F (0°C to 40°C)	20% to 75%	525 to 795 (700 to 1060)
Mobile Power Unit	32°F to 104°F (0°C to 40°C)	20% to 93%	525 to 795 (700 to 1060)
Tablet for use with the HeartMate Touch™ App	32°F to 95°F (0°C to 35°C)	20% to 95%	535 to 795 (710 to 1060)
HeartMate Touch Wireless Adapter	32°F to 104°F (0°C to 40°C)	20% to 75%	525 to 795 (700 to 1060)
HeartMate 14 Volt Lithium-Ion Batteries^a	32°F to 104°F (0°C to 40°C)	20% to 75%	525 to 795 (700 to 1060)
Battery Charger	32°F to 104°F (0°C to 40°C)	20% to 75%	525 to 795 (700 to 1060)
System Controller, Backup System Controller^{a, b}	32°F to 104°F (0°C to 40°C)	20% to 93%	525 to 795 (700 to 1060)
11 Volt Lithium-Ion Backup Battery	32°F to 104°F (0°C to 40°C)	20% to 93%	525 to 795 (700 to 1060)

Table 2.1 Operating Conditions

Chapter 2 System Operations

- a Standby components (extra 14 Volt Lithium-Ion batteries, backup System Controller) should be maintained at conditions within the acceptable ranges so that they are available for immediate use. A backup System Controller and charged batteries must remain with the patient at all times for use in an emergency. Patient and caregiver training must address this crucial need.
- b Every six months, the “sleeping” backup System Controller must be connected to a power source to charge the 11 Volt Lithium-Ion backup battery inside. If the 11 Volt Lithium-Ion backup battery inside the backup System Controller is not charged every six months, its charge level will diminish and there may not be sufficient power to support the pump if the backup System Controller is in use during a power emergency (see *Maintaining Backup System Controller Readiness: Six Month Charging and Self Test* on page 2-51).

System Controller Overview

The HeartMate 3™ System Controller acts as the central power and communication hub for the HeartMate 3 LVAS. It passes power from the Power Module, the Mobile Power Unit, Lithium-Ion Batteries, or its own integrated emergency backup supply, down to the LVAD via the Driveline. The HeartMate 3 System Controller constantly monitors system performance through communication with the implanted LVAD and Controller internal measurements and alerts the user to any alarm conditions by activating membrane panel LEDs and integrated audio annunciators. Further information on alarm conditions as well as system status can be attained by the user from the front panel LCD on the System Controller. When connected to a HeartMate Touch™ Communication System, the System Controller sends information regarding the System Controller and Pump Status once per second to provide additional information to the user. This link also allows the clinician to set new patient operating parameters (e.g. pump speed) and provides a link for downloading trend and/or event recorder data.

The System Controller has been designed with redundant power and communication lines to the pump Driveline. This not only provides for a robust continuous operation of the implanted pump in the event of a fault situation, but also alerts the user to possible Driveline degradation.

The System Controller is the chief decision making component of the system. It instructs the pump at which speed to operate, either by passing a command sent by the HeartMate Touch Communication System or when in Power Saver mode or at a Pulsatility Index (PI) event detection.

The System Controller connects to the LVAD via a Driveline that passes through the patient's abdomen. The Driveline carries power to the pump. The Driveline also supplies information from the pump to the System Controller (**Figure 2.5**).

The System Controller uses sounds, lights, symbols, and on-screen messages to communicate with users (**Figure 2.6**).

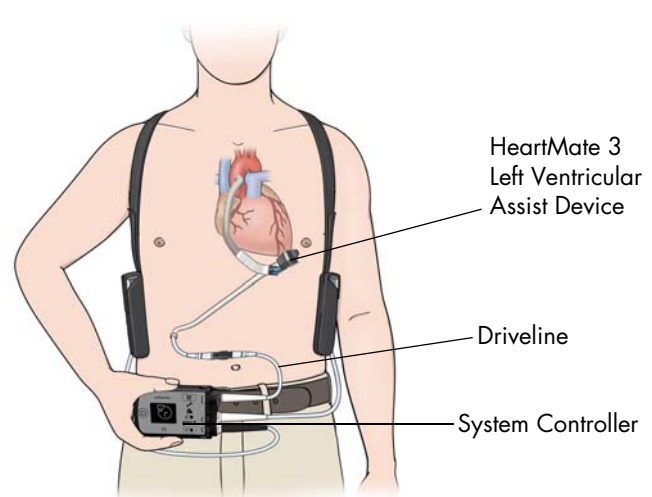

Figure 2.5 HeartMate 3™ Left Ventricular Assist System



- System Controller Driveline Connector: links the Modular Cable portion of the Driveline to the System Controller.
- Power Cable Connectors: link external power source (Power Module, Mobile Power Unit, or 2 HeartMate 14 Volt Lithium-Ion Batteries) to the System Controller.
- User Interface: buttons, lights, and screen where system data, alarms, and user instructions appear.
- Backup battery: located inside the System Controller, powers the pump for at least 15 minutes during a power-loss emergency.

Figure 2.6 System Controller Major Components

The System Controller is described in the following sections:



System Controller User Interface Overview

This section describes the visual display of system operations and on-screen messages.

See page 2-14.



System Controller Driveline Connector

This section provides instructions on connecting and disconnecting the Driveline.

See page 2-20.



System Controller Power Cable Connectors

This section describes two power cables on the System Controller (one white and one black) that connect the System Controller to either the Power Module, the Mobile Power Unit, or two 14 Volt Lithium-Ion batteries.

See page 2-26.



Performing a System Controller Self Test

This section provides instructions on how to perform a daily self test to check the function of the System Controller's audible and visual alarms.

See page 2-29.



System Controller Battery Power Gauge

This section describes the battery power gauge function to show the approximate charge status of the power source that is connected to the System Controller's power cables.

See page 2-30.

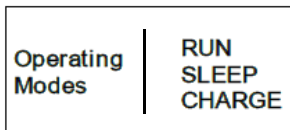

System Controller Operating Modes

This section describes the System Controller's three operating modes (Run, Sleep, and Charge) and provides an overview with instructions on how to switch between modes.

See page 2-33.



System Controller Backup Battery Power

This section provides a functional overview with instructions on how to replace the 11 Volt Lithium-Ion backup battery that is inside the System Controller.

See page 2-39.

System Controller Warnings and Cautions

WARNING !

- Check the System Controller Driveline connector to confirm that the Driveline is securely inserted in the socket. If the Driveline disconnects from the System Controller, the pump stops. If the Driveline disconnects from the System Controller, promptly reconnect it to resume pump operation.
- At least one System Controller power cable must be connected to a power source (Power Module, Mobile Power Unit, or two HeartMate 14 Volt Lithium-Ion batteries) at all times.
- Keep the System Controller power cables dry and away from water or liquid. If the System Controller power cables come into contact with water or liquid, the system may fail to operate properly or you may get a serious electric shock.
- Do not allow patients to swim or take tub baths while implanted with the Left Ventricular Assist Device. Patient immersion in water may cause the device to stop.
- Do not allow patients to shower without a doctor's permission. HeartMate 3™ patients may be allowed to shower, but only after sufficient post-operative healing and with a doctor's permission.
- If external system components have contact with water or moisture, the Pump may stop. If a HeartMate 3 patient is approved for showering, he or she must always use the Shower Bag during every shower. The Shower Bag protects external system components from water or moisture.
- The 11 Volt Lithium-Ion backup battery should be used only for temporary support during a power-loss emergency. The 11 Volt Lithium-Ion backup battery inside the HeartMate 3 System Controller provides enough power to run the implanted HeartMate 3 pump for at least 15 minutes if the main power source (either the Power Module, Mobile Power Unit, or two HeartMate 14 Volt Lithium-Ion batteries) is disconnected or fails. Inappropriate use of the 11 Volt Lithium-Ion backup battery may result in diminished run time during a power-loss emergency.
- Do not use damaged, defective, or expired 11 Volt Lithium-Ion backup batteries in the System Controller. Using a damaged, defective, or expired System Controller backup battery may cut operating time during an emergency or cause the pump to stop.
- Use only a Abbott-supplied HeartMate 14 Volt Lithium-ion battery with the HeartMate 3 System Controller. Using another battery may cause the pump to stop.
- Do not open, crush, heat above 104°F (40°C), or incinerate batteries because of the risk of fire and burns. Follow manufacturer's instructions.
- Malfunction of the 11 Volt Lithium-Ion backup battery may cause the System Controller to become excessively hot. If this occurs, switch to the backup System Controller.

CAUTION !

- Do not drop the System Controller or subject it to extreme physical shock.
- Instruct patients (and family member or caregiver) to advise hospital personnel immediately if they drop the System Controller. Emphasize to users the importance of not waiting to report a dropped System Controller, even if everything seems fine. Dropping the System Controller can cause trauma or tissue damage at the Driveline exit site, which can increase the patient's risk of serious infection.
- Instruct the patient to stabilize their Driveline at all times to avoid pulling on or moving the Driveline at the exit site. Pulling on or moving the Driveline can keep the exit site from healing or damage an already healed exit site. Exit site trauma or tissue damage can increase the patient's risk of getting a serious infection. Emphasize to the patient and/or family member or caregiver the importance of not pulling on or moving the Driveline.
- Do not twist, kink, or sharply bend the Driveline, System Controller power cables, Power Module patient cable, or Mobile Power Unit patient cable, which may cause damage to the wires inside, even if external damage is not visible. Damage to the Driveline or cables could cause the Left Ventricular Assist Device to stop. If the Driveline or cables become twisted, kinked, or bent, carefully unravel and straighten.
- The 11 Volt Lithium-Ion backup battery inside the backup System Controller must be charged at least once every six months. Failure to charge the 11 Volt Lithium-Ion backup battery inside the backup System Controller may result in diminished or no support during a power-loss emergency when the backup System Controller is in use.
- Damage to the redundant electrical wires inside the Driveline can occur that is not visible to the user. Signs of Driveline damage include (but are not limited to):
 - The System Controller alarming when the Driveline is moved or when the patient changes position.
 - Driveline Power Fault or Driveline Communication Fault yellow wrench and audio alarm (see *System Controller User Interface Components* on page 2-15).
 - Fluid oozing from the external portion of the Pump Cable.
 - Pump stoppage.
- When connecting power cable connectors, do not try to join them together without first aligning the half circles inside the connectors. Joining together misaligned power cable connectors may damage them.

CAUTION ! (Continued)

- Never use tools to tighten power cable connectors; securely hand tighten only. Using tools may damage the connectors.
- Confirm that the patient's backup System Controller has had the 11 Volt Lithium-Ion backup battery installed and the time and date have been set.
- A backup System Controller and charged batteries must remain with the patient at all times for use in an emergency. Patient and caregiver training must address this crucial requirement.
- The System Controller uses lights, sounds, and on-screen messages to communicate with users about system operation. HeartMate 3 patients with sight or hearing impairment may need extra help using the System Controller.
- Do not place the System Controller on bare skin for an extended time. The System Controller surface temperature can become uncomfortably warm, especially when the room temperature is above 104°F (40°C).

System Controller User Interface Overview

The user interface on the System Controller is the primary interface for users during routine system operation. It uses sounds, lights, symbols, and on-screen messages to communicate about how the system is working. The user interface provides a visual display of system operation and on-screen messages that instruct how to respond to alarms and other situations (**Figure 2.7**).

HeartMate 3™ patients (and their family members/caregivers) must be thoroughly trained on how to interpret and use the user interface prior to discharge (see *Educating and Training Patients, Families, and Caregivers* on page 6-67).

For situations that require attention, and depending on the urgency, the System Controller issues include one of two types of alarms: hazard and advisory. Hazard alarms occur for conditions that are potentially life threatening for the patient and require immediate attention. Advisory alarms are important, but not life threatening. For more information on System Controller alarms and how to resolve them, see *System Controller Alarms* on page 7-2.

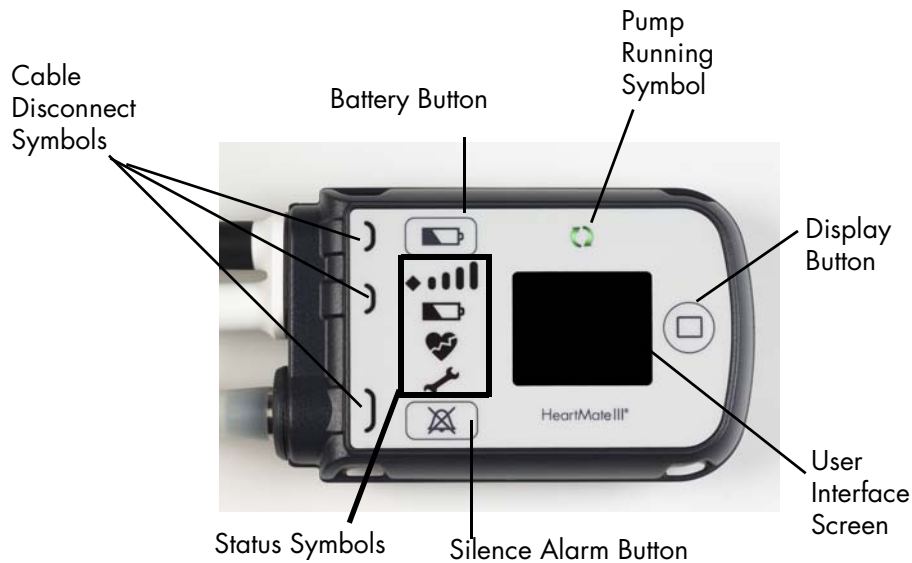

Figure 2.7 System Controller User Interface

System Controller User Interface Components

The buttons, lights, symbols, and display screen on the user interface are introduced below in **Table 2.2**.





<p>Pump Running Symbol</p> 	<p>The Pump Running symbol on the user interface is illuminated green when the Left Ventricular Assist Device is running.</p>
<p>Low Battery Alarm</p> 	<p>The red low battery symbol illuminates when less than 5 minutes of battery power remain (applicable only during 14 Volt Lithium-Ion battery-powered operation).</p> <p>This is a Hazard alarm. When the red battery symbol illuminates, immediately replace the depleted batteries with a fully-charged pair, or switch to the Power Module or the Mobile Power Unit.</p> <p>For more information, see page 7-15.</p>
<p>Yellow Wrench Alarm</p> 	<p>The yellow wrench symbol illuminates when the System Controller detects a mechanical, electrical, or software issue with the system.</p> <p>This is an Advisory alarm. When the yellow wrench illuminates, check the screen for troubleshooting instructions.</p> <p>For more information, see page 7-8.</p>
<p>Red Heart Alarm</p> 	<p>The red heart symbol illuminates when the System Controller detects a problem that could cause serious injury or death.</p> <p>This is a Hazard alarm. When the red heart illuminates, check the screen for instructions and take immediate action to resolve the problem.</p> <p>For more information, see page 7-6.</p>
<p>Black Power Cable Alarm</p> 	<p>The yellow light near the black power cable connector illuminates when the black power cable becomes loose or disconnects from the System Controller.</p> <p>This is an Advisory alarm. If the black power cable disconnects or becomes loose, promptly restore the connection.</p> <p>For more information, see page 7-17.</p>

Table 2.2 System Controller Symbols, Alarms, Buttons

White Power Cable Alarm



The yellow light near the white power cable connector illuminates when the white power cable becomes loose or disconnects from the System Controller.

This is an **Advisory** alarm. If the white power cable disconnects or becomes loose, promptly restore the connection.

For more information, see page 7-17.

Driveline Connector Alarm



The red light near the Driveline connector illuminates when the Driveline becomes loose or disconnects from the System Controller.

This is a **Hazard** alarm. If the Driveline loosens or disconnects from the System Controller, promptly restore the connection. If the Driveline is not reconnected immediately, the pump stops.

For more information, see page 7-13.

Battery Power Gauge



The battery power gauge shows the approximate charge status of the power source that is connected to the System Controller's white and black power cables—either the 14 Volt Lithium-Ion batteries or the Power Module. The number of green bars means power remaining. The more green bars mean more power remaining.

For more information, see page 2-30.





Yellow diamond = less than 15 minutes of battery power remain. Appearance of this symbol indicates an **Advisory** alarm. If the yellow diamond comes on, promptly replace the low batteries with two fully-charged batteries, or switch to the Power Module or the Mobile Power Unit. Do this as soon as possible.

For more information, see page 7-18.

IMPORTANT! *The battery power gauge does not show the charge status of the System Controller's backup battery (the battery inside the System Controller). To check the status of the System Controller's backup battery, see Viewing Pump and System Information on page 2-18.*

Table 2.2 System Controller Symbols, Alarms, Buttons (Continued)

<p>Battery Button</p> 	<p>The battery button is used for the following:</p> <ul style="list-style-type: none"> • Operating the battery power gauge: Press and release the battery button. For more information, see page 2-30. • Starting a System Controller self test: Press and hold the battery button for 5 seconds and then release it. Perform a self test daily on your running System Controller, and monthly on your backup System Controller when it is in Charge Mode. For more information, see page 2-29. • Putting a running System Controller into Sleep Mode: When a System Controller is no longer in use, it can be put to sleep by disconnecting the Driveline and power source, and pressing and holding the battery button for 5 seconds and then releasing it. For more information, see page 2-38.
--	--

<p>Silence Alarm Button</p> 	<p>The silence alarm button is used for the following:</p> <ul style="list-style-type: none"> • Silencing an active alarm: Press and release the silence alarm button to silence an active alarm on the System Controller. How long it is silenced depends on the alarm (see <i>System Controller Alarms</i> on page 7-2). The LCD screen on the System Controller will display the audio alarm silence symbol. IMPORTANT! Using the silence alarm button only silences the alarm. It does not fix the alarm condition. • Viewing the last six System Controller alarms on the screen: Press and release the silence alarm button (⊗) and the display button (◻) at the same time to display the last six System Controller alarms on the screen. For more information, see page 7-3.
--	---

<p>Display Button</p> 	<p>The display button activates the information display screen. Press and release the display button one or more times repeatedly to display information about pump speed, power, flow, pulsatility index, and the charge status of the System Controller's 11 Volt Lithium-Ion backup battery. The display button is functional only when a System Controller is in use. For more information, see page 2-19.</p>
--	---

Table 2.2 System Controller Symbols, Alarms, Buttons (Continued)

Pulse Mode

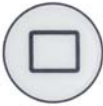

The presence of the black triangle indicates that the HeartMate 3 system is operating in Pulse Mode. Once every 2 seconds, the HeartMate 3 pump will automatically modify its speed to create an artificial pulse.

Table 2.2 System Controller Symbols, Alarms, Buttons (Continued)

Viewing Pump and System Information

Viewing information about the pump is useful when recording daily values or trying to resolve system problems on the telephone. When the System Controller is running, the user interface can display the following information about current system operations:

- Speed
- Mode (indicated as Pulse Mode by )
- Flow
- Pulsatility Index (abbreviated as "PI" on the screen)
- Power
- Charge status of the System Controller's backup battery (11 Volt Lithium-Ion)

To view information on the user interface screen, press and release the display button (). Each push of the display button brings up a new screen. Each screen illuminates for 15 seconds before it goes black, unless another button is pushed. The screens are always displayed in the same order, starting with the first (Speed) screen. A dot at the bottom of each screen provides navigational information about which of the five screens is in view.

Table 2.3 shows the display sequence.







Button Press	Description	Screen Displayed (Example)	Meaning
	Press display button ONCE		Pump speed in revolutions per minute (RPM)  Triangle indicates that the pump is in Pulse Mode.
	Press display button TWO times		Pump flow in liters per minute (LPM)
	Press display button THREE times		Pulsatility Index (PI)
	Press display button FOUR times		Power in watts (W)
	Press display button FIVE times		The System Controller's backup battery (located inside the System Controller and used to temporarily run the pump during a power emergency) has three charge status states: 1. Charged (ready for use). 2. Charging (actively charging). 3. Fault (there is a fault or problem with the backup battery that could affect its reliability).
	Press display button SIX times		Blank screen indicates the screen is off, which is normal.

Table 2.3 System Controller Display Screen Sequence

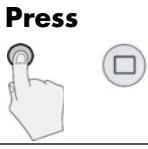
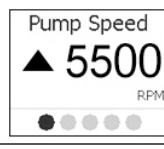
Note: On-screen messages come in many different languages and can be changed from the HeartMate Touch™ App to support your patient's needs. See *System Controller Language* on page 4-37.

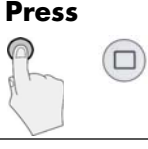
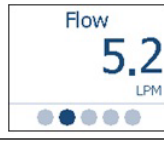
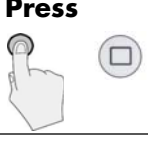
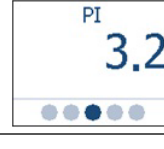
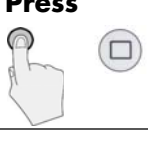
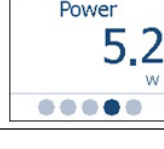
System Controller Driveline Connector

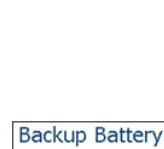
The System Controller Driveline Connector attaches the Driveline (comprised of the Pump Cable and the Modular Cable) to the System Controller (**Figure 2.8**). The System Controller Driveline Connector uses a double-lock feature that lowers the risk of accidentally disconnecting the Driveline.

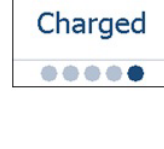

Figure 2.8 System Controller Driveline Connector on the System Controller

The System Controller continually monitors the connection status of the System Controller Driveline Connector. If the System Controller detects a problem, it immediately alarms.

The Driveline is initially connected to the patient's System Controller during the procedure to implant the Left Ventricular Assist Device. The same System Controller remains in use unless it requires replacement for clinical or technical reasons (see *The Backup System Controller* on page 2-45).

It is impossible to connect (or disconnect) the Driveline without first rotating the Safety Lock on the back of the System Controller into the "unlocked" position.



Figure 2.9 Move the Safety Lock to the Unlocked Position

When the Driveline is properly and fully inserted into the System Controller Driveline Connector port, the Driveline cannot be removed without firmly pressing the red button under the raised Safety Lock (**Figure 2.9**).

If there is a problem with the Driveline connection, the System Controller alarms immediately.

Connecting the Driveline to the System Controller

FOR THIS TASK YOU NEED:

A running System Controller, programmed with patient-specific settings

TO CONNECT THE DRIVELINE TO THE SYSTEM CONTROLLER:

1. Orient the System Controller so the display is facing down.
2. Rotate the Safety Lock to the unlocked position (**Figure 2.10**).



Figure 2.10 Unlock the Safety Lock

CAUTION !

Do NOT insert a misaligned Driveline Cable Connector. When inserting the Driveline Cable Connector, do NOT orient the System Controller so the display is facing up.

3. **Align** the WHITE arrow/alignment mark on the Driveline Cable Connector with the WHITE arrow on the System Controller Driveline Connector(**Figure 2.11**).



Figure 2.11 Align the Arrows

4. **Insert** the Driveline Cable Connector into the socket (**Figure 2.12**), pressing firmly until it snaps into place. The Left Ventricular Assist Device may take up to 10 seconds to start running when the cable is fully and properly inserted in the socket (if pump set speed is set above 4000 rpm).

IMPORTANT! The arrow/alignment mark on the driveline is no longer visible when properly connected.



Figure 2.12 Insert and Lock the Driveline Into the Socket

Note: The Safety Lock cannot move to the locked position unless the Driveline is fully and properly inserted.

5. Move the Safety Lock to the locked position, so that it covers the red button.

IMPORTANT! If the Safety Lock does not fully cover the red button, the driveline is not connected. Disconnect and reconnect the driveline.

6. Tug on the inserted metal end of the Modular Cable to check the connection. Do not pull on or bend the Driveline. If there is a problem with the connection, the System Controller immediately alarms with a Driveline Disconnected alarm. This is a Hazard alarm.

CAUTION !

Do not pull on or bend the Driveline that connects the pump to the System Controller. Pulling on or bending the Driveline may damage wires inside, even if external Driveline damage is not visible.

Disconnecting the Driveline from the System Controller

WARNING !

- Failure to connect to a running System Controller may result in serious injury or death.
- Failure to adhere to the following instructions may result in serious injury or death.

FOR THIS TASK YOU NEED:

A running System Controller

TO DISCONNECT THE DRIVELINE FROM THE SYSTEM CONTROLLER:

1. Orient the System Controller so the display is facing down.
2. Rotate the Safety Lock to the unlocked position (see **Figure 2.13**).



Figure 2.13 Unlock the Safety Lock

3. Firmly press the red button under the Safety Lock, while pulling the System Controller Driveline Connector from the socket. Grasp the bend relief of the Modular Cable while removing it. Do not pull on or bend the System Controller Driveline Connector (see **Figure 2.14**).



Figure 2.14 Grasp the Metal End and Remove the Driveline

WARNING !

The Left Ventricular Assist Device stops if the Driveline is disconnected from the System Controller. If the Driveline is disconnected, reconnect it as quickly as possible to restart the pump. If the System Controller does not work, replace with a backup System Controller.

System Controller Power Cable Connectors

Two power cables on the System Controller (a black connector and a white connector) connect the System Controller to the Power Module, the Mobile Power Unit, or two 14 Volt Lithium-Ion batteries (**Figure 2.15**).



Figure 2.15 Black and White Power Cable Connectors on the System Controller

The System Controller power cable connectors (and the corresponding connectors for the Power Module patient cable and the Mobile Power Unit patient cable connectors) are color coded. Always connect black-to-black and white-to-white. Both System Controller power cables provide equal power. However, the cable with the white connector transmits signals between the System Controller and HeartMate Touch Communication System. Refer to *Set Up the HeartMate Touch™ Communication System* on page 4-7. The data link does not work without a white-to-white connection.

During routine operation, the HeartMate 3™ Left Ventricular Assist System is powered by one of the following power sources:

- **Power Module**—The Power Module is used when the patient is indoors, stationary, or sleeping. The System Controller and the Power Module are connected through the Power Module patient cable. The cable transfers power from the Power Module to the System Controller. See *Using the Power Module* on page 3-4 for details.
- **Mobile Power Unit**—The Mobile Power Unit can be used when the patient is indoors, stationary, or sleeping. The System Controller and the Mobile Power Unit are connected through the Mobile Power Unit patient cable. The cable transfers power from the Mobile Power Unit to the System Controller. See *Using the Mobile Power Unit* on page 3-34 for details.
- **Two HeartMate 14 Volt Lithium-Ion batteries**—HeartMate batteries are used to power the system during battery-powered operation when AC electricity is not wanted or is unavailable. Batteries are used in pairs. Each battery is inserted into a 14 Volt battery clip. The clips transfer battery power to the System Controller with two power cables, one for each clip. Without battery clips, the batteries cannot transfer power to the system. When fully charged, a pair of new HeartMate 14 Volt Lithium-Ion batteries can power the system for up to 10-17 hours, depending on the activity level of the patient. See *Using HeartMate 14 Volt Lithium-Ion Batteries* on page 3-51 for details.

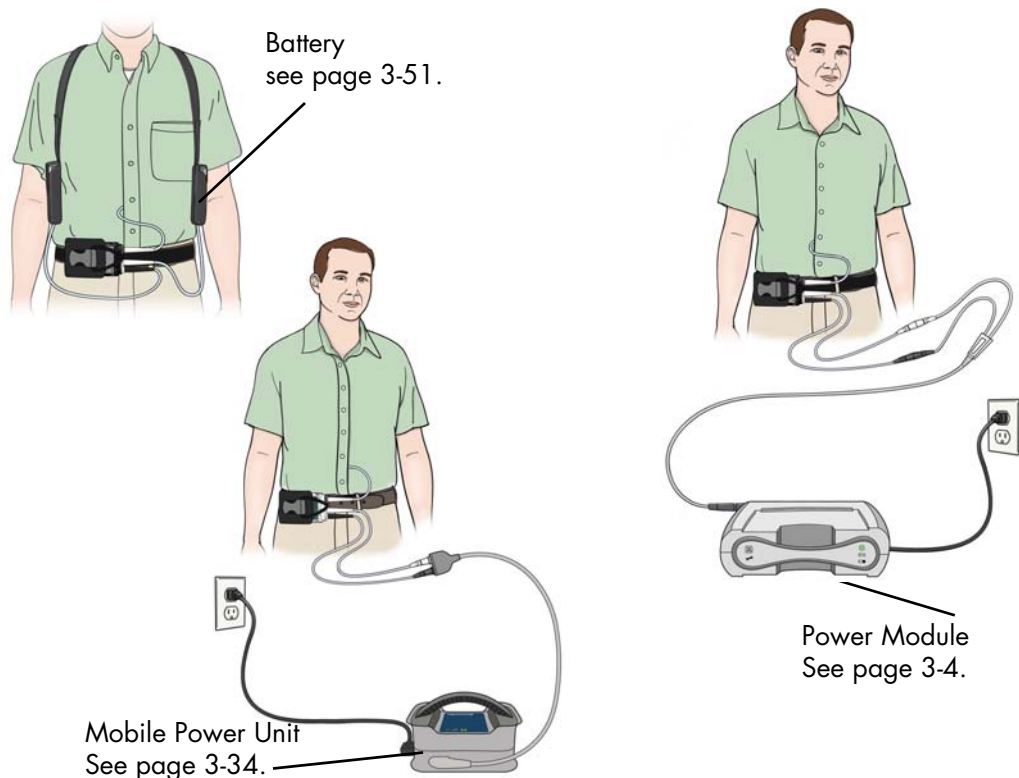

Figure 2.16 The HeartMate 3™ Left Ventricular Assist Device on Battery Power (top), Power Module Power (right), and Mobile Power Unit Power (bottom)

The System Controller continually monitors the connection status of the power cable connectors. If the System Controller detects a problem, it immediately alarms. For more information about the alarm, see *Power Cable Disconnected Alarm* on page 7-17.

WARNING !

The System Controller must be connected to the Power Module, Mobile Power Unit, or two HeartMate 14 Volt Lithium-Ion batteries at all times when connected to a patient.

Performing a System Controller Self Test

Use a daily System Controller self test to check the audible and visual alarm indicators on the user interface, as well as the status of the backup battery for the System Controller. During the Self Test, the pump set speed will not be changed.

The System Controller self test is a loud and bright function. All of the audible and visual indicators should come on and “Self Test” should appear on the screen (**Figure 2.17**).





Figure 2.17 User Interface During System Controller Self Test

Perform the self test at least daily on the running System Controller. A backup System Controller in Charge Mode can be tested as well, if needed.

Consider testing the System Controller at the same time daily to establish a routine.

TO PERFORM A SYSTEM CONTROLLER SELF TEST:

1. Press and hold the battery button () for five seconds.
2. Check that:
 - “Self Test” (first briefly white, then black) appears on the screen.
 - All symbols and indicators on the user interface illuminate at the same time.
 - System Controller is making a loud, steady, audio alarm tone.
3. Release the battery button (). All the audible indicators/lights should remain on for 15 seconds, after which the audible indicators/lights stop, the screen goes black, and the self test is complete.

If all of the alarms and lights come on together as described above, the System Controller passed the self test. If any of the lights remain off, or if the audible indicators do not sound or they produce sounds other than a loud steady tone, there is a problem with the System Controller. Do not use a System Controller that fails its self test.

4. If the System Controller fails the self test, complete the following steps:
Replace it with the backup System Controller and contact Abbott for a new backup System Controller.

IMPORTANT! If an alarm occurs during a self test, the self test terminates and the alarm's on-screen indicator remains active. A System Controller self test cannot be initiated during the following alarms: any Hazard alarm, Power Cable Disconnected Advisory alarm, Low Battery Power Advisory alarm.

System Controller Battery Power Gauge

The battery power gauge shows the approximate charge status of the power source that is connected to the System Controller's white and black power cables—the 14 Volt Lithium-Ion batteries, the Power Module, or the Mobile Power Unit. The number of green bars means power remaining. The more green bars mean the more power remaining.

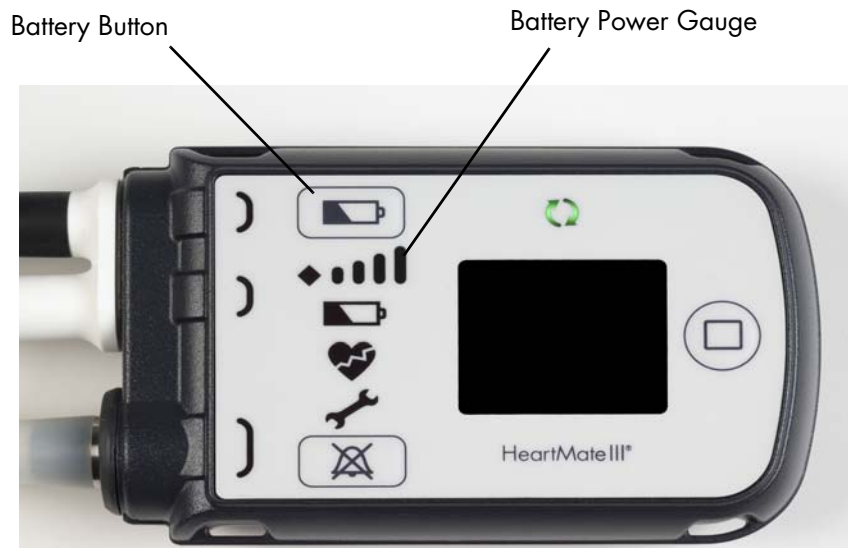



Figure 2.18 Battery Power Gauge Showing Full Charge

To activate the battery power gauge, press and release the battery button () on the user interface (**Figure 2.18**).

IMPORTANT! The battery power gauge does not show the charge status of the System Controller's backup battery (the battery inside the System Controller). To check the status of the System Controller's backup battery, refer to *Viewing Pump and System Information* on page 2-18.

14 Volt Lithium-Ion battery power:





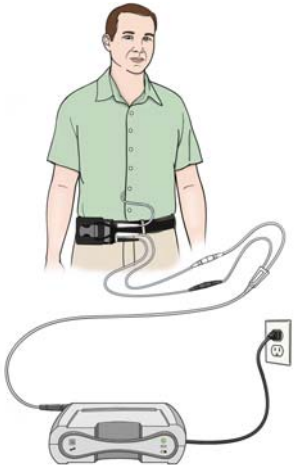

	4 green bars = 75–100% of battery power remains.
	3 green bars = 50–75% of battery power remains.
	2 green bars = 25–50% of battery power remains.
	1 green bar = less than 25% of battery power remains.

IMPORTANT! Every HeartMate 14 Volt Lithium-Ion battery also has its own on-battery gauge. It shows the power level for that battery. The on-battery readout communicates information about a single source using five green bars. The System Controller battery power gauge communicates information about a combined source of power using four green bars. For more information, see *Checking Battery Charge Status Using the On-Battery Power Gauge* on page 3-56.

Power Module power:



	4 green bars = Normal Power Module operation.
	3 green bars = Running on the Power Module backup battery and 50–75% of battery power remains.
	2 green bars = Running on the Power Module backup battery and 25–50% of battery power remains.
	1 green bar = Running on the Power Module backup battery and less than 25% of battery power remains.

Mobile Power Unit power:

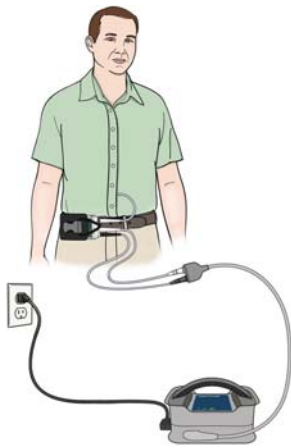

4 green bars = Normal Mobile Power Unit operation.

Recognizing Low Battery Alarms

If the yellow diamond or the red battery illuminate, the system's power level is dangerously low. This condition prompts a Low Battery Power alarm.



Yellow diamond: Less than 15 minutes of combined battery power remain. This is an **Advisory** alarm.

For more information, see *Low Battery Power Alarm (less than 15 minutes remain)* on page 7-18.



Red battery: Less than 5 minutes of combined battery power remain. This is a **Hazard** alarm.

For more information, see *Low Battery Power Alarm (less than 5 minutes remain)* on page 7-15.

If either the yellow diamond or the red battery illuminate, immediately replace the depleted batteries with a fully-charged pair, or switch to the Power Module or Mobile Power Unit (see *Switching from Battery Power to the Power Module* on page 3-69 or *When to Connect to the Mobile Power Unit* on page 3-46).

System Controller Operating Modes

The System Controller has three operating modes:

- Run Mode—The system is functioning and is in use.
- Sleep Mode—The system is not in use, but is ready to function. The backup System Controller is predominantly in Sleep Mode.
- Charge Mode—The system is not connected to a Driveline, but is connected to a power source to charge and maintain readiness of its internal 11 Volt Lithium-Ion backup battery.

IMPORTANT! The backup System Controller must be put into Charge Mode every six months to charge its backup battery.

Each mode has a distinct function, which is described in more detail below.

Run Mode

Run Mode is the usual state for the running System Controller. **Figure 2.19** shows a System Controller in Run Mode.



Figure 2.19 System Controller in Run Mode While on Battery Power (left) and the Power Module (right)

In Run Mode, the Pump Running symbol is illuminated green (🔄) and the System Controller is:

- Connected to a power source (the Power Module, the Mobile Power Unit, or two HeartMate™ 14 Volt Lithium-Ion batteries).
- Connected to the Left Ventricular Assist Device via the Driveline.
- Sending power to the pump via the Driveline.
- Controlling and monitoring physiological and operating conditions.
- Displaying data about physiological and operating conditions.
- Using user interface indicators to reflect System Controller and pump conditions.
- Responding to user interface button pushes.
- Charging the 11 Volt Lithium-Ion backup battery inside the System Controller.
- Communicating with the HeartMate Touch™ Communication System, if connected.
- Able to perform a System Controller self test.

For instructions on switching from Run Mode to Sleep Mode, see *Switching Operating Modes* on page 2-36.

Sleep Mode

Sleep Mode is the usual state for a backup System Controller. **Figure 2.20** shows the System Controller in Sleep Mode.



Figure 2.20 System Controller in Sleep Mode

The backup System Controller remains in Sleep Mode until either: 1) it is put into Charge Mode (connected to power) or 2) it is used in Run Mode (used to replace the running System Controller).

In Sleep Mode, the Pump Running symbol (🌀) is off (black), and the backup System Controller is:

- Disconnected from an external power source and powered off.
- Disconnected from the Driveline.
- Not displaying operating/alarm data on the information display screen.
- Not responding to user interface button pushes.
- Not charging the 11 Volt Lithium-Ion backup battery inside the System Controller.
- Disconnected from and not communicating with the HeartMate Touch Communication System.

For instructions on switching from Sleep Mode to Run Mode or Charge Mode, see *Switching Operating Modes* on page 2-36.

Charge Mode

The backup System Controller must be connected to power for the 11 Volt Lithium-Ion backup battery to charge. **Figure 2.21** shows the System Controller in Charge Mode while connected to the Power Module (left) and batteries (right).



Figure 2.21 System Controller in Charge Mode

Once every six months, the “sleeping” backup System Controller must be connected to an external power source (Power Module, Mobile Power Unit, or two HeartMate 14 Volt Lithium-Ion batteries). Connecting to power and putting the System Controller into Charge Mode allows its 11 Volt Lithium-Ion backup battery to charge. A fully-depleted 11 Volt Lithium-Ion backup battery takes up to three hours to charge.

In Charge Mode, the Pump Running symbol (🌀) is off (black), and the backup System Controller is:

- Charging the 11 Volt Lithium-Ion backup battery inside the System Controller.
- Able to perform a System Controller self test.
- Disconnected from the Driveline.
- Displaying charging status or any active alarms.
- Not responding to silence alarm (🚫) or display (🔲) buttons.

Switching Operating Modes

Figure 2.22 shows how to transition between operating modes.

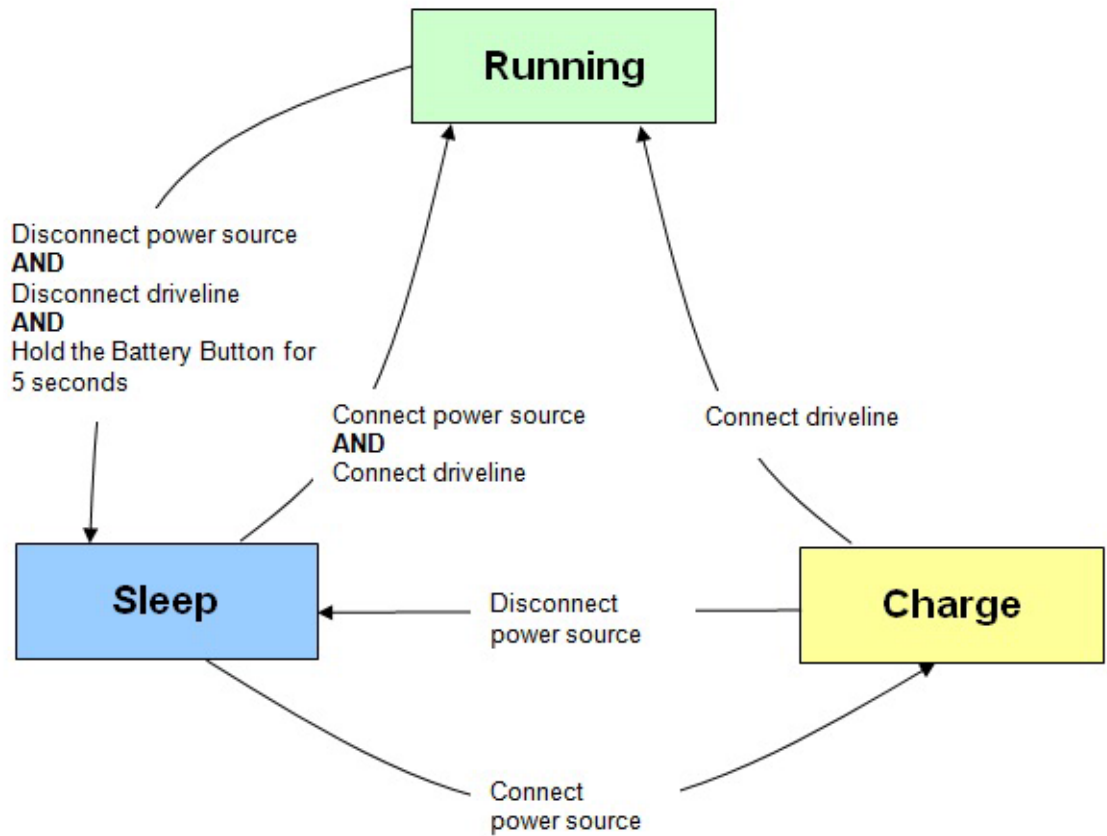



Figure 2.22 System Controller Operating Modes

TO SWITCH FROM SLEEP MODE TO RUN MODE:

1. Connect the System Controller to a power source (Power Module, Mobile Power Unit, or two HeartMate 14 Volt Lithium-Ion batteries).
2. Connect the Driveline to the System Controller (see *Connecting the Driveline to the System Controller* on page 2-22).
3. The Pump Running symbol is illuminated green() and the System Controller is in Run Mode.

TO SWITCH FROM CHARGE MODE TO RUN MODE:

This procedure assumes that the System Controller is not in use, but is connected to a power source and is in Charge Mode.

1. Connect the Driveline to the System Controller (see *Connecting the Driveline to the System Controller* on page 2-22).
2. The Pump Running symbol is illuminated green () and the System Controller is in Run Mode.

TO SWITCH FROM CHARGE MODE TO SLEEP MODE:

Disconnect the System Controller from its power source (Power Module, Mobile Power Unit, or two HeartMate 14 Volt Lithium-Ion batteries).

Note: The Driveline must be disconnected to put in sleep mode.

TO SWITCH FROM SLEEP MODE TO CHARGE MODE:





IMPORTANT! Do not permit patients to perform this task without approval and proper training.

Connect the System Controller to a power source (Power Module, Mobile Power Unit, or two HeartMate 14 Volt Lithium-Ion batteries).

It can take up to 3 hours to charge the 11 Volt Lithium-Ion backup battery. During this time, “Charging” and five dashes scroll across the bottom of the screen. This indicates that the 11 Volt Lithium-Ion backup battery is actively charging.

“Charging Complete” appears on the screen when the battery has finished charging. After the backup battery is charged, the System Controller can either be put into Run Mode for immediate use or into Sleep Mode to await future use.

TO SWITCH FROM RUN MODE TO SLEEP MODE:

1. Disconnect the Driveline from the System Controller. Press and release the silence alarm button () to silence the Driveline Disconnected Alarm.
2. Disconnect the System Controller from its power source (Power Module, Mobile Power Unit, or two HeartMate 14 Volt Lithium-Ion batteries). Press and release the silence alarm button () to silence the Power Cable Disconnected Alarm.
3. Press and hold the battery button () for five seconds. The following appears on the screen:
“Hold” accompanied by a reverse countdown from five dots to one dot.
4. When the countdown ends, the screen goes black, the Pump Running symbol is black (), and the System Controller is in Sleep Mode. If this sequence is not fully completed, the System Controller will not enter Sleep Mode.

System Controller Backup Battery Power

An 11 Volt Lithium-Ion backup battery inside the System Controller, that is installed post-implant, provides at least 15 minutes of backup power to the Left Ventricular Assist Device if the in-use power source is disconnected or fails. To provide backup power, the 11 Volt Lithium-Ion backup battery must be properly installed and fully charged.

The 11 Volt Lithium-Ion backup battery is intended only for backup power during a power emergency. Emphasize to patients that inappropriate use during non-emergencies may reduce the power available to them in a true emergency. Backup battery use is automatically recorded by the System Controller. This allows for follow-up training with patients, if needed, to reinforce that usage should be limited to power emergencies. See *Backup Battery Tab* on page 4-39 for instructions on accessing 11 Volt Lithium-Ion backup battery usage records.

After proper installation, the rechargeable 11 Volt Lithium-Ion backup battery recharges automatically, any time the running System Controller is connected to a power source (Power Module, Mobile Power Unit, or two HeartMate 14 Volt Lithium-Ion batteries). It takes up to three hours to charge a fully-depleted 11 Volt Lithium-Ion backup battery. Although rechargeable, the backup battery has a limited lifespan (36 months from manufacture date). Therefore, it may be necessary to install a replacement backup battery if the current one expires, or if prompted by a Backup Battery Fault alarm.



Figure 2.23 Backup Battery Fault Alarm

The backup System Controller also has an 11 Volt Lithium-Ion backup battery. The sleeping backup System Controller must be connected to power (put into Charge Mode) at least every six months to charge the backup battery inside the backup System Controller (see *Maintaining Backup System Controller Readiness: Six Month Charging and Self Test* on page 2-51).

WARNING !

The 11 Volt Lithium-Ion back up battery inside the System Controller will not by itself start a HeartMate 3 LVAD if both of the System Controller's power cables are disconnected from a power source. Always ensure that the power cables are connected to a power source to ensure that the HeartMate 3 Pump will restart during a System Controller exchange.

Replacing a Backup Battery in the System Controller

The 11 Volt Lithium-Ion backup battery is first installed in a running System Controller after implantation, and after the sterile field has been broken (see *Installing the Backup Battery in the System Controller* on page 5-62). The System Controller can remain attached to the patient while replacing the 11 Volt Lithium-Ion backup battery.

If the original 11 Volt Lithium-Ion backup battery exceeds its expiration date or if a Backup Battery Fault alarm appears on the information display screen, the battery must be replaced. See *Installing the Backup Battery in the System Controller* on page 5-62 for a complete list of warnings and cautions related to the 11 Volt Lithium-Ion backup battery.

The HeartMate Touch™ App displays information about the System Controller 11 Volt Lithium-Ion backup battery charge level, and the time remaining before its replacement is mandatory. Depending upon an outpatient's clinic schedule, replacement of the 11 Volt Lithium-Ion backup battery should be considered when less than 6 months remain before the mandatory replacement date.

FOR THIS TASK YOU NEED:

- 1 replacement 11 Volt Lithium-Ion backup battery (obtained from Abbott)
- 1 lever to remove the screw cover of the battery compartment (included with the replacement 11 Volt Lithium-Ion backup battery)
- 1 screwdriver to loosen the four battery cover screws (included with the replacement 11 Volt Lithium-Ion backup battery)
- 1 spare screw cover (included with the replacement 11 Volt Lithium-Ion backup battery)
- 1 running System Controller that is connected to a power source (Power Module, Mobile Power Unit, or 2 14 Volt Lithium-Ion batteries)

TO REPLACE THE BACKUP BATTERY IN THE SYSTEM CONTROLLER:

1. Confirm that the date and time on the running System Controller are correct before attempting to replace the backup battery. If the date or time is incorrect, the System Controller's Backup Battery Alarm may occur (see *System Controller Alarms* on page 7-2).
2. Gather equipment (**Figure 2.24**); place within easy reach.



Figure 2.24 11 Volt Backup Battery Replacement Kit

3. Use the lever to remove the screw cover of the battery compartment on the System Controller (**Figure 2.25**).



Figure 2.25 Use the Lever to Remove the Screw Cover

4. Use the screwdriver to loosen the four screws on the battery compartment (**Figure 2.26**).



Figure 2.26 Use the Screwdriver to Loosen the Screws

5. Remove the battery compartment cover.
6. Remove the current 11 Volt Lithium-Ion battery from the battery compartment:
 - a. Grasp the end of the ribbon cable that is attached to the current battery.
 - b. Gently remove the ribbon cable from the battery socket (**Figure 2.27**).



Figure 2.27 Remove Ribbon Cable from Battery Socket

- c. Discard the used battery (see *Product Disposal* on page 8-11).
7. Retrieve the replacement 11 Volt Lithium-Ion backup battery.
8. Align the arrow on the end of the ribbon cable with the arrow on the end of the replacement backup battery.
9. Insert the end of the ribbon cable into the battery socket.

10. Confirm that the backup battery is properly connected by verifying that:
 - Either a green or amber indicator light appears on the battery (green indicates that the backup battery is fully charged; amber indicates that the battery is charging).

AND

- The backup battery installation graphic no longer appears on the information display screen.
11. Place the backup battery and attached ribbon cable inside the battery compartment (**Figure 2.27**).
 12. Place the cover over the battery compartment.
 13. Use the provided screwdriver to tighten the four screws on the cover (**Figure 2.28**).



Figure 2.28 Tighten the Screws

14. Replace the screw cover.

IMPORTANT! A newly inserted battery needs to finish charging before it can reliably provide backup power. It takes approximately 3 hours for a fully-depleted 11 Volt Lithium-Ion backup battery to become fully charged. "Charging Complete" appears on the information display screen when the newly-installed 11 Volt Lithium-Ion backup battery has finished charging (see *Charge Mode* on page 2-35).

Setting the System Controller Clock

The System Controller has an internal clock. The clock tracks the timing of system events and monitors the expiration date of the System Controller's 11 Volt Lithium-Ion backup battery.

IMPORTANT! Be aware that installing an 11 Volt Lithium-Ion backup battery may prompt a Controller Clock Not Set advisory alarm on the HeartMate Touch™ App.

To resolve a Controller Clock Not Set advisory alarm, use the HeartMate Touch App to reset the System Controller's internal clock (see *Controller Date & Time* on page 4-33). Make sure the HeartMate Touch App clock is correct before relying on it.

The Backup System Controller

HeartMate 3™ patients receive two System Controllers: one to actively use (running), and a reserve (backup) in case the running System Controller experiences a failure.



Overview: Running Versus Backup System Controller

See page 2-46.



Configuring the Backup System Controller

The backup System Controller must have its 11 Volt Lithium-Ion backup battery installed.

See page 2-47.



Maintaining Backup System Controller Readiness: Six Month Charging and Self Test

Every six months, the backup System Controller's internal backup battery must be charged and a self test must be performed.

See page 2-51.

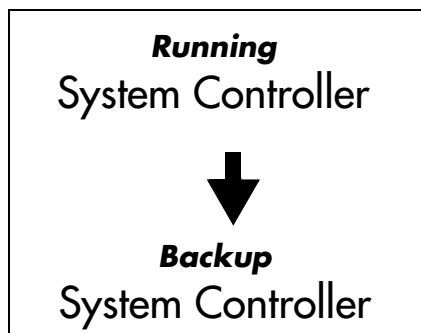

Changing Controllers

If the running System Controller experiences a failure, it must be replaced.

See page 2-54.

Overview: Running Versus Backup System Controller

Every HeartMate 3™ patient receives a backup System Controller, which is identical to the running System Controller. If a failure occurs on the running System Controller, it may need to be replaced with the backup System Controller. For this reason, and in case of an emergency, the backup System Controller must remain with the patient at all times (**Figure 2.29**).



Running System Controller	Backup System Controller
 <p data-bbox="297 1079 792 1140">On Power Module or Mobile Power Unit</p>	<p data-bbox="870 825 1195 856">If needed, ready to use</p> 
 <p data-bbox="297 1619 472 1650">On Batteries</p>	<p data-bbox="870 1304 1252 1335">Backup is not connected to:</p> <ul data-bbox="870 1350 1032 1423" style="list-style-type: none"> • Power • Driveline

Figure 2.29 System Controller States

IMPORTANT! To replace the running System Controller with the backup System Controller, see *Replacing the Current System Controller* on page 2-54.

Configuring the Backup System Controller

The backup System Controller's internal backup battery must be installed and the clock set. This way, the backup System Controller is ready if the running System Controller needs to be replaced.

IMPORTANT! Once system operating parameters have been entered (Pump Speed & Low Speed Limit), the pump stores these values. Therefore, the backup System Controller does not need to have the patient's parameters programmed. Once the backup System Controller is connected to the pump, the operating parameters are transferred from the pump to the Controller.

FOR THIS TASK YOU NEED:

- 1 new and packaged System Controller complete with 11 Volt Lithium-Ion backup battery and *Patient Handbook*
- 1 working Power Module with patient cable and AC power cord connected
- 1 Tablet for use with the HeartMate Touch App, prepared for use (see *Set Up the HeartMate Touch™ Communication System* on page 4-7)
- 1 HeartMate Touch Wireless Adapter for connecting the HeartMate Touch Communication System to the Power Module, through a Bluetooth® pairing
- 1 functioning and grounded (3-prong) AC electrical outlet

TO CONFIGURE THE BACKUP SYSTEM CONTROLLER

1. Remove the System Controller, the 11 Volt Lithium-Ion backup battery, and the *Patient Handbook* from the System Controller packaging.
2. Connect the backup System Controller to the Power Module.

Note: The System Controller will alarm. This action is normal. You will see **Figure 2.30**:

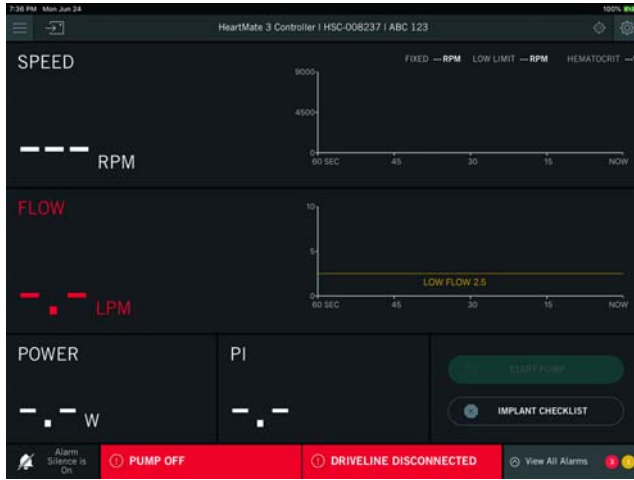

Figure 2.30 HeartMate Touch™ App (left) and System Controller (right)

3. Set the System Controller clock via the Settings panel (see **Figure 2.31**).

For more information, see *Controller Date & Time* on page 4-33.

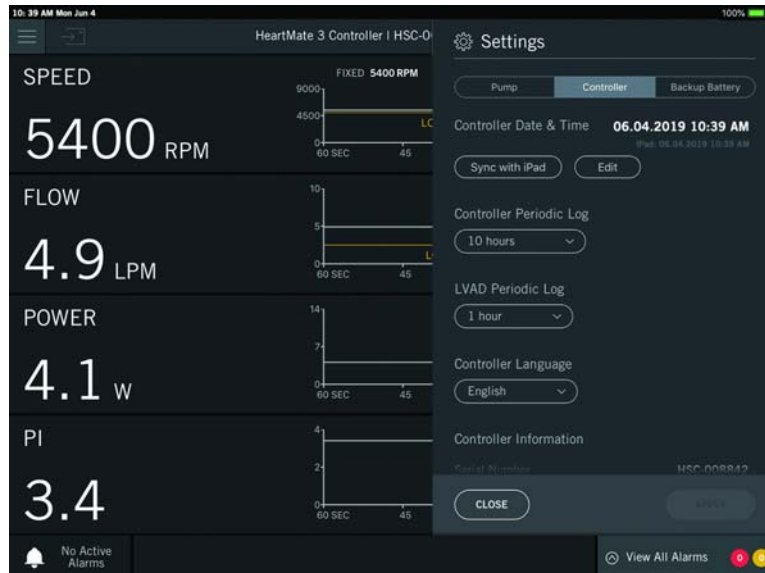

Figure 2.31 Settings Panel

4. Set the System Controller's language, if needed, via the Settings panel (shown above).

For more information, see *System Controller Language* on page 4-37.

5. Install the 11 Volt backup battery into the System Controller (**Figure 2.32**).

For more information, see *Installing the Backup Battery in the System Controller* on page 5-62.



Figure 2.32 Install Backup Battery

6. Disconnect power from the System Controller.

Note: The HeartMate Touch App will have PUMP OFF, DRIVELINE DISCONNECTED, and LOW FLOW X min alarms active, and the System Controller will show a red heart alarm (❤️) and display a “Connect Driveline” message. This is normal.

7. Put the System Controller to sleep. Press and hold the battery button (🔋) for five seconds.

Note: The following “Hold” screen appears accompanied by a reverse countdown from five dots to one dot (**Figure 2.33**). When the countdown ends, the System Controller is in Sleep Mode.



Figure 2.33 Hold Screen

Maintaining Backup System Controller Readiness: Six Month Charging and Self Test

Over time, the backup battery inside the System Controller loses power and must be recharged every six months. You must “awaken” it, connect it to power, and put it into Charge Mode. Connecting the backup System Controller to power charges its internal 11 Volt Lithium-Ion backup battery. While the backup System Controller is in Charge Mode, you should perform a self test.

FOR THIS TASK YOU NEED:

- 1 backup System Controller
- 1 power source (Power Module, Mobile Power Unit, or two HeartMate™ 14 Volt Lithium-Ion batteries)

TO PERFORM BACKUP SYSTEM CONTROLLER SIX MONTH CHARGING AND SELF TEST:

1. Connect the backup System Controller to a power source (Power Module, Mobile Power Unit, or two HeartMate 14 Volt Lithium-Ion batteries) (**Figure 2.34**).



Figure 2.34 System Controller on Power Module Power (left) and Battery Power (right)

2. When the System Controller is connected to power, its user display screen shows “Charging” or “Charging Complete” (**Figure 2.35**).



Figure 2.35 System Controller Charging or Charging Complete

IMPORTANT! Do not remove power until the words Charging Complete appear. It can take up to three hours to charge the System Controller's backup battery.

3. Perform a self test on the backup System Controller. Press and hold the battery button () for five seconds (**Figure 2.36**).

For more information, see *The Backup System Controller* on page 2-45.

Note: A self test can only be performed when power is connected to the System Controller.



Figure 2.36 System Controller Self Test

4. Disconnect power from the backup System Controller. This will put the backup System Controller back into Sleep Mode. No further action is needed for six months.

5. Put the backup System Controller into its Protection Bag (**Figure 2.37**).

For more information, see *Using the Protection Bag* on page 6-60.



Figure 2.37 Backup System Controller in Protection Bag

Replacing the Current System Controller

There are two ways in which the System Controller can be exchanged. The first method assumes that only the System Controller is exchanged and that a second power source is not available. The second exchange method involves exchanging the System Controller using a second power source.

The Pump Cable is the cable that is implanted inside the patient. One end connects directly to the pump and the other end exits the body. One end of the Modular Cable connects to the end of the Pump Cable that exits the body. The other end of the Modular Cable connects directly to the System Controller. Collectively, the cables are referred to as the Driveline.

CAUTION !

Ensure that the patients understand the need for having a caregiver present during System Controller exchange and that all labeling instructions are followed, including calling the hospital contact.

IMPORTANT! The ability to successfully replace a System Controller may be affected by several factors such as native cardiac output, cognitive function, and so on. Any of these may change over the course of LVAD support, and therefore should be periodically assessed.

Replacing the Current System Controller with One Power Source

To replace the current System Controller with the replacement System Controller:

1. If your current System Controller is alarming, silence the audio alarms for 2 minutes by pressing the silence alarm button (⊗).
2. Locate your replacement HeartMate 3 System Controller.
3. Move the white connector's power source from the running System Controller to the backup System Controller. Fully secure the white nut until tight.

WARNING !

Failure to connect to a running System Controller may result in serious injury or death.

CAUTION !

- Do NOT insert a misaligned Driveline Cable Connector.
- When inserting the Driveline Cable Connector, do NOT orient the System Controller so the display is facing up.

4. To disconnect the Driveline from the current System Controller:
 - a. Orient the System Controller so the display is facing down.
 - b. Rotate the Safety Lock to the unlocked position (see **Figure 2.38**).



Figure 2.38 Unlock the Safety Lock

- c. Firmly press the red button under the Safety Lock, while pulling the System Controller Driveline Connector from the socket. Grasp the bend relief of the Driveline while removing it. Do not pull on or bend the System Controller Driveline Connector (see **Figure 2.39**).



Figure 2.39 Grasp the Metal End and Remove the Driveline

5. To connect the Driveline to the replacement System Controller:
 - a. **Align** the WHITE arrow/alignment mark on the Driveline Cable Connector with the WHITE arrow on the System Controller Driveline Connector (**Figure 2.40**).



Figure 2.40 Align the Arrows

- b. **Insert** the Driveline Cable Connector into the socket pressing firmly until it snaps into place. The Left Ventricular Assist Device may take up to 10 seconds to start running when the cable is fully and properly inserted in the socket (if pump set speed is set above 4000 rpm).

Note: The Safety Lock cannot move to the locked position unless the Driveline is fully and properly inserted.

6. Move the Safety Lock to the locked position, so that it covers the red button (**Figure 2.41**).



Figure 2.41 Closing the Safety Lock

7. Orient the System Controller so the display is facing up. **Confirm the green Pump Running symbol (🌀) is on.**
8. Disconnect the Black Power connection from the previously running System Controller and connect it to the replacement System Controller (and fully secure the black nut until tight) which is now supporting the patient.
9. Put the previously running System Controller into Sleep Mode. For further instructions, refer to *Turning Off the System Controller (Sleep Mode)* on page 2-61.

Replacing the Current System Controller with Multiple Power Sources

CAUTION !

Ensure that the patients understand the need for having a caregiver present during System Controller exchange and that all labeling instructions are followed, including calling the hospital contact.

To replace the current System Controller with the replacement System Controller using multiple power sources:

1. If your current System Controller is alarming, silence the audio alarms for 2 minutes by pressing the silence alarm button (⊗).
2. Locate your replacement HeartMate 3 System Controller and second power source.
3. Power the replacement System Controller by connecting both the White and Black Power connections (fully secure both the white and black nuts until tight).

WARNING !

Failure to connect to a running System Controller may result in serious injury or death.

CAUTION !

- Do NOT insert a misaligned Driveline Cable Connector.
- When inserting the Driveline Cable Connector, do NOT orient the System Controller so the display is facing up.

4. To disconnect the Driveline from the current System Controller:
 - a. Orient the System Controller so the display is facing down.
 - b. Rotate the Safety Lock to the unlocked position (see **Figure 2.42**).



Figure 2.42 Unlock the Safety Lock

- c. Firmly press the red button under the Safety Lock, while pulling the System Controller Driveline Connector from the socket. Grasp the bend relief of the Driveline while removing it. Do not pull on or bend the System Controller Driveline Connector (see **Figure 2.43**).



Figure 2.43 Grasp the Metal End and Remove the Driveline

5. To connect the Driveline to the replacement System Controller:
 - a. **Align** the WHITE arrow/alignment mark on the Driveline Cable Connector with the WHITE arrow on the System Controller Driveline Connector (**Figure 2.44**).



Figure 2.44 Align the Arrows

- b. **Insert** the Driveline Cable Connector into the socket pressing firmly until it snaps into place. The Left Ventricular Assist Device may take up to 10 seconds to start running when the cable is fully and properly inserted in the socket (if pump set speed is set above 4000 rpm).

Note: The Safety Lock cannot move to the locked position unless the Driveline is fully and properly inserted.

6. Move the Safety Lock to the locked position, so that it covers the red button (**Figure 2.45**).



Figure 2.45 Closing the Safety Lock

7. Orient the System Controller so the display is facing up. **Confirm the green Pump Running symbol (🔄) is on.**
8. Disconnect the Black Power connection and the White Power connection from the previously running System Controller.
9. Put the previously running System Controller into Sleep Mode. For further instructions, refer to *Turning Off the System Controller (Sleep Mode)* on page 2-61.

Turning Off the System Controller (Sleep Mode)

1. Disconnect the Driveline from the System Controller. Press and release the silence alarm button (🔇) to silence the Driveline Disconnected Alarm.
2. Disconnect the System Controller from its power source (Power Module, Mobile Power Unit, or two HeartMate 14 Volt Lithium-Ion batteries). Press and release the silence alarm button (🔇) to silence the Power Cable Disconnected Alarm.
3. Press and hold the battery button (🔋) for five seconds. The following appears on the screen:
“Hold” accompanied by a reverse countdown from five dots to one dot.

When the countdown ends, the screen goes black, the Pump Running symbol is black (🔌), and the System Controller is in Sleep Mode. If this sequence is not fully completed, the System Controller will not enter Sleep Mode.

Replacing the Modular Cable

One segment of the Driveline includes the Modular Cable. If the Modular Cable needs to be replaced due to damage or fatigue, it can be accomplished in two ways.

- Option 1: Replace the current Modular Cable with both a NEW Modular Cable and replacement System Controller.
- Option 2: Replace the current Modular Cable with a NEW Modular Cable only.

Option 1: Replacing the Current Modular Cable with a Replacement Modular Cable and a Replacement System Controller

This method is intended to have the shortest time that your pump is not running while changing the Modular Cable.

Before you begin, check that:

- The replacement Modular Cable is available.
- The replacement System Controller is available.
- You have an additional power source for the replacement System Controller.

PROCEDURE:

1. If your current System Controller is alarming, silence the audio alarms for 2 minutes by pressing the silence alarm button (⊗).
2. Gather all the replacement equipment: replacement Modular Cable and replacement System Controller.
3. Connect the additional power source (this can be batteries, the Power Module patient cable, or the Mobile Power Unit patient cable) to your replacement System Controller.

CAUTION !

Do NOT insert a misaligned Driveline Cable Connector. When inserting the Driveline Cable Connector, do NOT orient the System Controller so the display is facing up.

4. To connect the replacement Modular Cable to the replacement System Controller:
 - a. **Align** the WHITE arrow/alignment mark on the Driveline Cable Connector with the WHITE arrow on the System Controller Driveline Connector (**Figure 2.46**).



Figure 2.46 Align the Arrows

- b. **Insert** the Driveline Cable Connector into the socket, pressing firmly until it snaps into place.

Note: The Safety Lock cannot move to the locked position unless the Driveline is fully and properly inserted.

5. Move the Safety Lock to the locked position, so that it covers the red button (**Figure 2.47**).



Figure 2.47 Closing the Safety Lock

6. Disconnect your currently connected Modular Cable from the Pump Cable by rotating the locking nut of the inline connector until the locking nut spins freely (**Figure 2.48**). You will hear a clicking sound as you rotate the locking nut (this is normal). When the clicking sound has stopped, and the locking nut spins freely, then pull the connectors apart as shown in **Figure 2.49**.



Figure 2.48 Rotate the Locking Nut

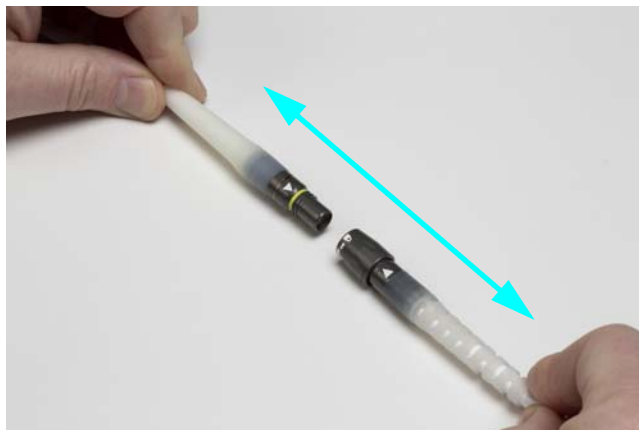

Figure 2.49 Pull the Connectors Apart

7. Connect the replacement Modular Cable (which has already been connected to the replacement System Controller) to the Pump Cable by aligning the white triangles and pushing the connectors firmly together (see **Figure 2.50**).

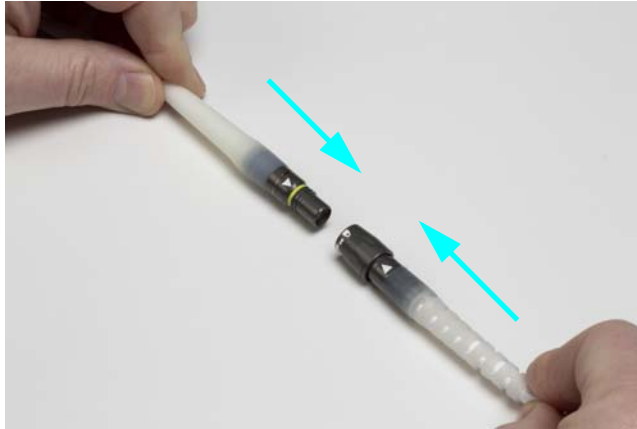

Figure 2.50 Align the White Triangles

8. Rotate the locking nut of the Modular inline connector until the clicking sound has stopped and the yellow line is hidden by the locking nut (see **Figure 2.51**).



Figure 2.51 Rotate the Locking Nut

9. Disconnect power and Modular Cable from the original System Controller and put the System Controller into Sleep Mode or it will continue to alarm.

Option 2: Replacing the Current Modular Cable with a Replacement Modular Cable

Before you begin, check that the replacement Modular Cable is available.

PROCEDURE:

1. If your current System Controller is alarming, silence the audio alarms for 2 minutes by pressing the silence alarm button (⊗).
2. To disconnect the current Modular Cable from the System Controller:
 - a. Orient the System Controller so the display is facing down.
 - b. Rotate the Safety Lock to the unlocked position (see **Figure 2.52**).



Figure 2.52 Unlock the Safety Lock

- c. Unlock the Locking Nut on your currently connected Modular Cable from the Pump Cable by rotating the locking nut of the inline connector until the locking nut spins freely (see **Figure 2.53**). You will hear a clicking sound as you rotate the locking nut (this is normal). When the clicking sound has stopped, and the locking nut spins freely, the locking nut has been unlocked.



Figure 2.53 Rotate the Locking Nut

- d. Firmly press the red button under the Safety Lock, while pulling the System Controller Driveline Connector from the socket. Grasp the bend relief of the Driveline while removing it. Do not pull on or bend the System Controller Driveline Connector (see **Figure 2.54**).



Figure 2.54 Grasp the Metal End and Remove the Driveline

CAUTION !

Do NOT insert a misaligned Driveline Cable Connector. When inserting the Driveline Cable Connector, do NOT orient the System Controller so the display is facing up.

3. To connect the replacement Modular Cable to the System Controller:
 - a. **Align** the WHITE arrow/alignment mark on the Driveline Cable Connector with the WHITE arrow on the System Controller Driveline Connector (**Figure 2.55**).



Figure 2.55 Align the Arrows

- b. **Insert** the Driveline Cable Connector into the socket, pressing firmly until it snaps into place.

Note: The Safety Lock cannot move to the locked position unless the Driveline is fully and properly inserted.

4. Move the Safety Lock to the locked position, so that it covers the red button (**Figure 2.56**).



Figure 2.56 Closing the Safety Lock

5. Pull apart the Modular inline Connector as shown in **Figure 2.57**.

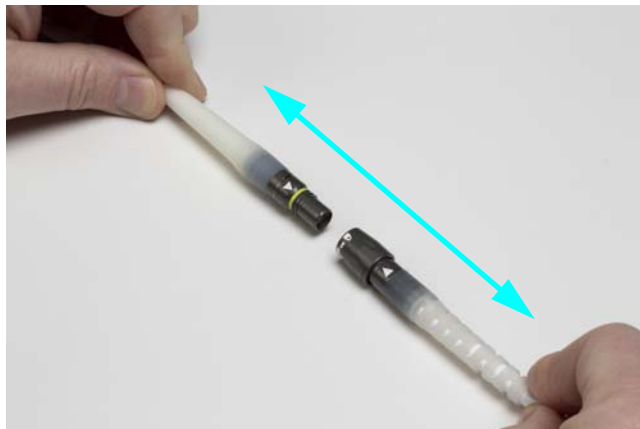

Figure 2.57 Pull the Connectors Apart

6. Connect the replacement Modular Cable (which has already been connected to the replacement System Controller) to the Pump Cable by aligning the white triangles and pushing the connectors firmly together (see **Figure 2.58**).

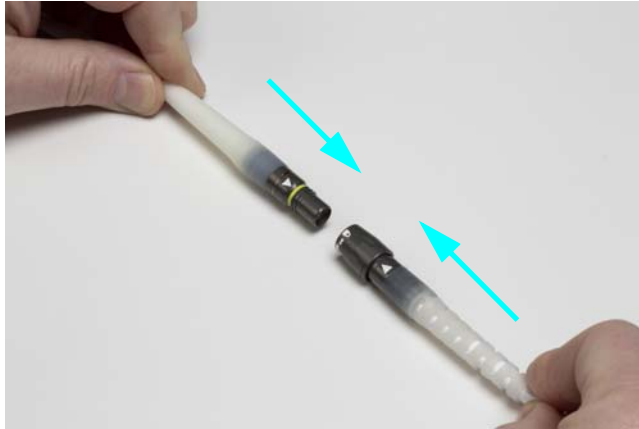

Figure 2.58 Align the White Triangles

7. Rotate the locking nut of the Modular inline connector until the clicking sound has stopped and the yellow line is hidden by the locking nut (see **Figure 2.59**).



Figure 2.59 Rotate the Locking Nut

POWERING THE SYSTEM

This section describes the various methods that can be used to power the HeartMate 3™ Left Ventricular Assist System.

Power Overview - - - - -	3-2
Using the Power Module - - - - -	3-4
Using the Mobile Power Unit - - - - -	3-34
Using HeartMate 14 Volt Lithium-Ion Batteries - - - - -	3-51
Switching Power Sources - - - - -	3-66
Battery Charger Overview - - - - -	3-73
Charging HeartMate Batteries - - - - -	3-80
Calibrating HeartMate Batteries - - - - -	3-84
Using the Charger to Check Battery Power - - - - -	3-86
Care and Maintenance of the Battery Charger - - - - -	3-87

Power Overview

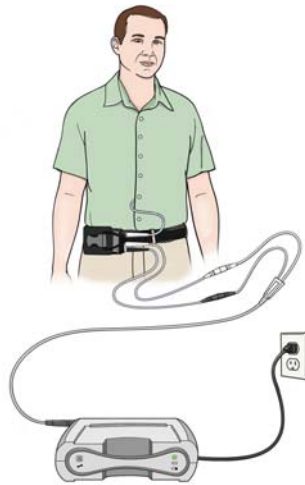

Power Module—The Power Module is intended for use in the clinical setting when the patient requires monitoring using the HeartMate Touch™ Communication System. The System Controller and the Power Module are connected through the Power Module patient cable. The cable transfers power from the Power Module to the System Controller.

See page 3-4.

Mobile Power Unit—The Mobile Power Unit is for home or clinical use when the patient does not require monitoring using the HeartMate Touch Communication System. The Mobile Power Unit is used when the patient is indoors, stationary, or sleeping. The System Controller and the Mobile Power Unit are connected through the Mobile Power Unit patient cable. The cable transfers power from the Mobile Power Unit to the System Controller.

See page 3-51.

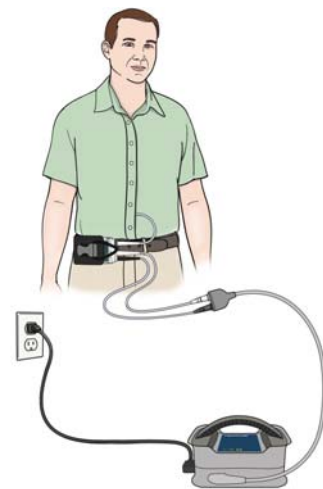

Two HeartMate 14 Volt Lithium-Ion batteries—HeartMate batteries are used to power the system during battery-powered operation when AC electricity is not wanted or is unavailable. Batteries are used in pairs and are discharged at the same time. Each battery is inserted into a 14 Volt battery clip. The clips transfer battery power to the System Controller with two power cables, one for each clip. Without battery clips, the batteries cannot transfer power to the system. When fully charged, a pair of new HeartMate 14 Volt Lithium-Ion batteries can power the system for up to 17 hours, depending on the activity level of the patient.

See page 3-51.



The Battery Charger is needed to charge, test, and calibrate the 14 Volt Lithium-Ion batteries. The Battery Charger can accommodate up to four batteries at one time. **See page 3-73.**

Using the Power Module

Overview

The HeartMate 3 Power Module (**Figure 3.1**):

- Provides power to the System Controller and pump.
- Provides power to the HeartMate Touch Wireless Adapter.
- Connects the HeartMate Touch™ Communication System to the System Controller for monitoring purposes.
- Echoes System Controller alarms.



Figure 3.1 Power Module

Required Components

The following components are required for connecting the Power Module to the System Controller:

- HeartMate Power Module with an installed Power Module backup battery
- Power Module patient cable
- Power Module power cord
- HeartMate 3 System Controller

WARNING !

- To avoid the risk of electrical shock, plug the Power Module into a properly tested and grounded (3-prong) AC electrical outlet that is dedicated to Power Module use.
 - Do not use an outlet that is controlled by a wall switch.
 - Do not use an adapter plug for an ungrounded wall outlet.
 - Do not use portable, multiple outlet (power strip) adapters.
- When using the Power Module to power the system, make sure that the Power Module patient cable is correctly connected to the Power Module.
- Do not use the Power Module or Mobile Power Unit in the presence of a flammable anesthetic mixture with air or with oxygen or nitrous oxide, or an explosion could occur.
- Keep the Power Module and Mobile Power Unit dry and away from water or liquid. If the Power Module comes into contact with water or liquid, it may fail to operate properly or you may get a serious electric shock.
- Ensure that the backup battery is connected prior to initial use and after the Power Module is shipped for service or maintenance. The Power Module contains an internal backup battery that provides approximately 30 minutes of backup power to the system during a power emergency. The Power Module ships with the backup battery disconnected. The battery must be connected prior to initial use. If the Power Module backup battery is not connected, the backup power source does not work.
- Do not disconnect the Power Module patient cable from the Power Module when troubleshooting for a "Not Receiving Data" message.
- At least one System Controller power cable must be connected to a power source (Power Module, Mobile Power Unit, or two HeartMate 14 Volt Lithium-Ion batteries) at all times.
- The patient must always connect to the Power Module or Mobile Power Unit for sleeping or when there is a chance of sleep. A sleeping patient may not hear System Controller alarms.
- Before using the Power Module, a trained individual must install the Power Module backup battery.
- Before using the Mobile Power Unit, the Mobile Power Unit batteries must be installed.
- Keep the Power Module plugged into electrical power at all times. If the Power Module is without electrical power for approximately 18 hours or more, the Power Module backup battery may be damaged.
- Do not connect a System Controller to both the Mobile Power Unit and the Power Module at the same time, or damage to the System Controller and injury to the patient may occur. First connect to HeartMate 14 Volt batteries.

WARNING ! (Continued)

- If the patient travels long distances, such as by aircraft, instruct the patient to ask for a travel safety plan. The travel plan must address steps necessary for safe travel, including the location of the nearest HeartMate implant center.
- The HeartMate Power Module and Mobile Power Unit radiate radio frequency energy. If not used according to instructions, the Power Module and the Mobile Power Unit may cause harmful interference with nearby devices. To confirm interference, unplug the Power Module and/or the Mobile Power Unit and observe the effect on devices in the area. If interference is detected, switch to battery power and then:
 - Re-orient or move the affected device or devices.
 - Increase the distance between the Power Module and/or the Mobile Power Unit and the affected device or devices.
 - Connect affected device or devices to an electrical outlet different from the outlet used to power the Power Module and/or the Mobile Power Unit.
- Do not use equipment or supplies other than those specified or sold by Abbott. The use of unauthorized replacement parts may affect electromagnetic compatibility of the Power Module with other devices. Potential interference may occur between the Power Module and other devices.
- If traveling by aircraft, the patient should be instructed to bring sufficient battery power to power the system until the destination is reached. Neither the Mobile Power Unit nor the Battery Charger should be used on aircraft.

CAUTION !

- The Power Module requires preventive maintenance at least once every 12 months. Preventive maintenance includes (but is not limited to): a functional test, replacing the Power Module backup battery (the backup battery is rechargeable but has a limited life), and replacing the Power Module patient cable.
- Power Module service and maintenance should be performed only by service personnel who are trained by Abbott.
- Do not clean or service the Power Module while it is providing power to the system.
- If the Tablet for use with the HeartMate Touch App is mounted on top of the Power Module, do not attempt to lift or carry the two components. Doing so may damage the Power Module and/or Tablet for use with the HeartMate Touch App.
- When connecting power cable connectors, do not try to join them together without first aligning the half circles inside the connectors. Joining together misaligned power cable connectors may damage them.
- Avoid positioning the Power Module such that the access to the power cord plug into the wall socket is limited and/or where disconnection of the plug from the wall socket is difficult.
- The Power Module has an AC Power Cord and Patient Cable, both of which may be a tripping hazard. Ensure that the patient, care givers, and all other persons near the Power Module are aware of this potential hazard.

Setting Up the Power Module Before Use

To set up the Power Module, perform these tasks:

- Install the Power Module backup battery.
- Connect the power cord.
- Connect the Power Module patient cable.

Installing the Power Module Backup Battery

After receiving the Power Module, a Abbott-trained individual must open the Power Module to install its backup battery. This must be done prior to using the Power Module.

WARNING !

After the Power Module backup battery is installed, the Power Module should be plugged into electrical power at all times. If the Power Module will be unplugged from electrical power for an extended time, such as for transport for service or maintenance, disconnect the Power Module backup battery to prevent damage to the battery.

FOR THIS TASK YOU NEED:

- 1 Power Module
- 1 crosshead (Phillips) screwdriver
- 1 Power Module backup battery

TO INSTALL THE POWER MODULE BACKUP BATTERY:

1. Place the Power Module on a flat, stable surface. Make sure the Power Module is unplugged from AC power and disconnected from the patient. Transfer the patient to battery power prior to disconnecting.
2. Inspect the Power Module for dents, chips, cracks, or other signs of damage. Do not use a Power Module that appears damaged. Contact Abbott for a replacement, if needed.

3. Use a crosshead (Phillips) screwdriver to loosen the two ¼-turn screws from the rear panel. The screws remain in the screw holes to ensure they are not lost (**Figure 3.2**).



Figure 3.2 Loosen the Screws

4. Open the battery compartment cover on the rear of the Power Module (**Figure 3.3**).



Figure 3.3 Remove the Battery Compartment Cover

5. Use the crosshead (Phillips) screwdriver to remove the metal bracket that will hold the internal battery in place (**Figure 3.4**).



Figure 3.4 Remove the Metal Bracket

6. Remove the Power Module backup battery from the packaging.
7. Place the black battery connector over the metal contact end of the backup battery. The contacts should "snap" into place. Gently pull on the connection to make sure it is secure (**Figure 3.5**).



Figure 3.5 Secure the Battery to the Battery Connector

The Power Module alarms (audio and visual) indicating that the unit is disconnected from AC power.

8. Press the Silence Alarm button (☒) on the user panel to silence the alarm. The alarm clears when AC power is applied to the Power Module.
9. Place the Power Module backup battery in the battery compartment (**Figure 3.6**).



Figure 3.6 Place the Battery in the Battery Compartment

10. Use the crosshead (Phillips) screwdriver to reattach the metal bracket. Make sure the white connectors and wires are not trapped under the metal bracket. Make sure the connection is secure (**Figure 3.7**).



Figure 3.7 Reattach Metal Bracket

11. Gently fold the wires and white connector along the top of the Power Module backup battery and over the metal bracket screws (**Figure 3.8**).



Figure 3.8 Fold the Wires and Connector Along the Top

12. Replace the battery compartment cover.

13. Use the crosshead (Phillips) screwdriver to tighten the two $\frac{1}{4}$ -turn screws. Make sure the screws are tight and the cover is securely closed (**Figure 3.9**).



Figure 3.9 Tighten the Screws

Connecting the Power Module Power Cord

FOR THIS TASK YOU NEED:

- 1 Power Module, with Power Module backup battery installed and connected
- Functioning and grounded (3-prong) AC electrical outlet dedicated to Power Module use and not controlled by a wall switch
- 1 Power Module power cord

TO CONNECT THE POWER MODULE POWER CORD:

1. Place the Power Module on a flat, sturdy surface.
2. Plug the power cord into the Power Module (**Figure 3.10**).



Figure 3.10 Plug the Power Cord into the Power Module

3. Lift the power cord retention clip into the locked position.
4. Insert the two ends of the clip into the holes. Make sure the clip is securely engaged (**Figure 3.11**).



Figure 3.11 Insert the Ends of the Clip Into the Holes

5. Plug the Power Module into a properly tested and grounded (3-prong) AC electrical outlet that is dedicated to Power Module use. Do not use an outlet that is controlled by a wall switch. Do not use an adapter plug for an ungrounded wall outlet. Do not use portable, multiple outlet (power strip) adapters.
6. Observe the front panel of the Power Module. The green "Power On" light should illuminate. If the light does not illuminate, the device may be defective. Do not use a defective device. Contact Abbott for a replacement, if needed.
See **Figure 3.12**.

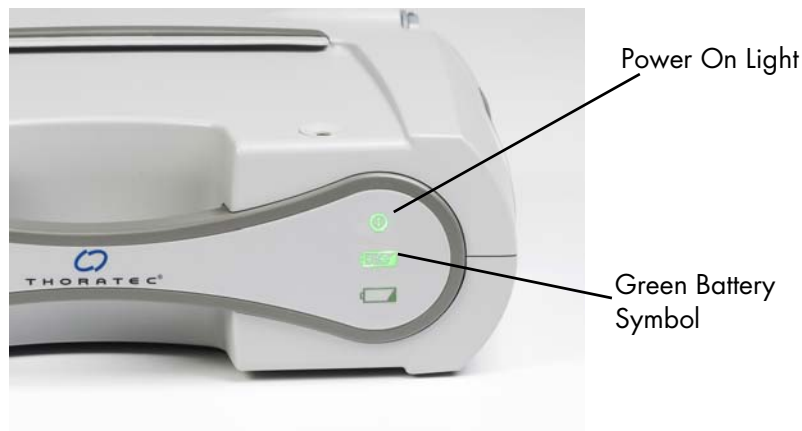

Figure 3.12 The Power Module is Ready for Use when the Power On and Charge Lights are Green

7. Within a few hours, the Power Module backup battery should be charged and ready for use, as indicated by a green battery symbol (**Figure 3.12**).

IMPORTANT! Wait for the Power Module backup battery to charge before using the Power Module for the first time, after service transportation, or after prolonged storage. It can take up to 3 hours to charge the backup battery.

Connecting the Power Module Patient Cable

The System Controller cannot connect to the Power Module without the Power Module patient cable. The 20-foot (6.1-meter) long Power Module patient cable allows patients some mobility while tethered to the Power Module.

FOR THIS TASK YOU NEED:

- 1 Power Module with Power Module backup battery installed and connected
- 1 running System Controller
- 1 Power Module patient cable
- 1 Power Module power cord to connect to an AC electrical power outlet

TO CONNECT THE POWER MODULE PATIENT CABLE:

1. Locate the Power Module patient cable (**Figure 3.13**).



Figure 3.13 Power Module Patient Cable

2. Line up the red dot on the patient cable with the red dot near the "♥" socket on the Power Module, and then insert the patient cable into the socket (**Figure 3.14**). The cable clicks into place when fully engaged in the socket.



Figure 3.14 Align the Red Dots

3. Tug gently on the black strain relief portion of the connector to confirm that the connection is tight. Do not pull on the cable. See **Figure 3.15**.



Figure 3.15 Tug on the Black Strain Relief Portion to Check the Connection

After the Power Module internal battery is charged, the Power Module is plugged in, and the Power Module patient cable is connected to the "♥" socket, the Power Module should be ready for use. However, before using the Power Module for the first time, be sure to perform a Power Module system self test (see *Performing a Power Module Self Test* on page 3-22).

If the Power Module patient cable remains connected to the Power Module when not in use, make sure the Power Module patient cable does not become damaged, and is placed to ensure the patient does not trip or fall.

When to Connect to the Power Module

Connect the System Controller to the Power Module (or Mobile Power Unit) when patients are stationary or relaxing indoors. Patients must always connect to the Power Module (or Mobile Power Unit) for sleeping (or when sleep is likely) because they may not awaken to hear low power alarms for batteries (see *System Controller Alarms* on page 7-2).

Use the Power Module patient cable to connect the System Controller to the Power Module (**Figure 3.16**). Use care when connecting or disconnecting power cables. For more information, see *Guidelines for Power Cable Connectors* on page 7-45.



Figure 3.16 Power Module Patient Cable

FOR THIS TASK YOU NEED:

- Running System Controller
- Working Power Module that is ready for use
- Working Power Module patient cable

TO CONNECT THE SYSTEM CONTROLLER TO THE POWER MODULE:

1. Gather equipment.
2. Confirm that the Power Module is ready for use (see *Setting Up the Power Module Before Use* on page 3-8).

3. Grasp the single-connector end of the Power Module patient cable (**Figure 3.17**).



Figure 3.17 Single-Connector End of the Power Module Patient Cable

4. Locate the red dot on the single-connector end of the Power Module patient cable connector (**Figure 3.18**).



Figure 3.18 Note the Red Dot on the Connector

5. Align the red dot on the connector with the red dot near the “heart” socket (♥) on the Power Module.

- Firmly insert the single-connector end into the “heart” socket (♥) on the Power Module (**Figure 3.19**). The connector clicks into place when correctly inserted.



Figure 3.19 Align the Red Dot on the Connector with the Red Dot on the Power Module

- Test the connection by tugging gently on the flexible strain-relief portion of the inserted connector.

CAUTION !

Do not pull on or bend the cable, as this could damage it.

- Place the black and white System Controller power cable connectors within easy reach (**Figure 3.20**).



Figure 3.20 Black and White System Controller Power Cable Connectors

9. Place the black and white Power Module patient cable connectors within easy reach (**Figure 3.21**).



Figure 3.21 Black and White Power Module Patient Cable Connectors

10. If currently using battery power (see *Using HeartMate 14 Volt Lithium-Ion Batteries* on page 3-51):
- Place the batteries and attached battery clips within easy reach.
 - Unscrew and disconnect only the white System Controller power cable connector from the attached battery clip. Do not remove the black connector!

IMPORTANT! The Power Cable Disconnected alarm comes on when a power cable is removed from power. This is normal. The alarm continues until the connection is restored or the silence alarm button () is pressed.

- Promptly align opposite half circles inside the white System Controller power cable connector and the white Power Module patient cable connector (**Figure 3.22**).

CAUTION !

Do not try to join together misaligned connectors. Doing so can damage them.

- Firmly push together the two connectors.

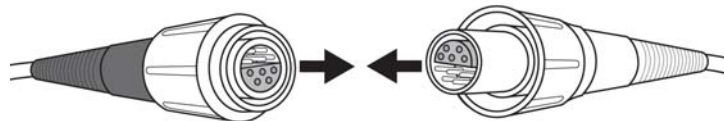

Figure 3.22 Align the Half Circles on the Connectors

- Securely hand tighten the connector nut. Do not use tools.
- Unscrew and disconnect only the black System Controller power cable connector from the attached battery clip.

- g. Promptly align opposite half circles inside the black System Controller power cable connector and the black Power Module patient cable connector. Firmly push together the two connectors.

CAUTION !

Do not try to join together misaligned connectors. Doing so can damage them.

- h. Securely hand tighten the connector nut. Do not use tools.



Figure 3.23 System Controller Power Cables Connected to Power Module Patient Cables

Monitoring Power Module Performance

The computer inside the Power Module is continually monitoring Power Module performance. If the Power Module computer detects a problem or malfunction, the yellow wrench symbol appears on the front of the Power Module. The yellow wrench is accompanied by an audio tone (a steady or beeping tone, depending on the condition). See *Handling Power Module Alarms* on page 7-37 for guidelines on handling Power Module alarms.

Performing a Power Module Self Test

Perform a Power Module self test before using the Power Module for the first time and at least once daily to make sure that the Power Module is working properly. A self test may be performed while the Power Module is powering the pump.

FOR THIS TASK YOU NEED:

- 1 Power Module, with Power Module backup battery connected
- Functioning and grounded (3-prong) AC electrical outlet that is dedicated to Power Module use and not controlled by a wall switch

TO PERFORM A POWER MODULE SELF TEST:

1. Press and hold the Power Module's silence alarm button () for five seconds.
2. Listen for 3 beeps and watch the front of the Power Module. The lights should come on in sequence—one at a time, not all at once.
3. If any of the following occurs, the Power Module may have a problem:
 - No sound
 - Anything other than 3 beeps (such as continuous beeping or a broken tone)
 - All the lights come on at once
 - All the lights remain off
 - One of the lights does not come on
4. If any of these conditions occur, please contact Abbott. For Abbott contact information, see the *Back Cover* of this manual. Otherwise, the Power Module passed the self test and is ready for use.

For guidelines on responding to Power Module alarms, see *Handling Power Module Alarms* on page 7-37.

Power Module Backup Power

The Power Module has an internal backup battery. A new Power Module backup battery provides approximately 30 minutes of backup power to the HeartMate 3™ system if power fails or is disconnected. Over time, the internal battery may provide shorter periods of backup power.

The Power Module backup battery remains charged as long as the Power Module remains connected to AC power. If the Power Module is disconnected from external power, the Power Module backup battery operates the Left Ventricular Assist System and the Power Module alarms until the battery is depleted. The backup battery automatically disengages after power is restored.

Make sure that the Power Module backup battery is charged prior to use. See **Table 3.1** for a description of the charge status indicators for the Power Module backup battery.

Keep the Power Module plugged into AC power at all times to make sure that the Power Module backup battery is charged and ready for use in case of power interruption. If the Power Module is without AC power for approximately 18 hours or more, the Power Module backup battery may be damaged. If the Power Module backup battery is damaged, an alarm is generated on the Power Module (see *Power Module Alarms* on page 7-38). Emphasize to patients that inappropriate use during non-emergencies may reduce the power available to them in a true emergency.

If the Backup Battery Malfunction alarm occurs, replace the backup battery immediately. Only trained individuals should replace the battery. Call Abbott for assistance, if needed.

The Power Module internal backup battery is rechargeable. However, the battery has a limited lifespan. The backup battery is replaced during annual planned Power Module maintenance (see *Cleaning and Maintenance* on page 8-4).

During Power Module power failure, transfer a patient from the Power Module to a Mobile Power Unit or battery-powered operation (see *Switching from the Power Module to Battery-Powered Operation* on page 3-66).

Note: The HeartMate Touch Wireless Adapter will not be powered if AC power is not connected.

Checking the Charge Status of the Power Module Backup Battery

Indicator symbols on the front panel of the Power Module illuminate to indicate the charge status of the Power Module backup battery. **Table 3.1** describes the indicator symbols.





<p>Green Charge Lamp</p>		<p>The Power Module backup battery is charged and ready for use. See Figure 3.24.</p>
<p>Yellow Charge Lamp</p>		<p>The Power Module backup battery is charging. See Figure 3.25.</p>
<p>Yellow Battery Advisory Symbol</p>		<p>Less than 15 minutes of Power Module backup battery power remain. Promptly switch to another power source. See Figure 3.26.</p>
<p><i>accompanied by beeping audio tone</i></p>		
<p>Red Battery Hazard Symbol</p>		<p>Less than 5 minutes of Power Module backup battery power remain. Immediately switch to another power source. See Figure 3.27.</p>
<p><i>accompanied by beeping audio tone</i></p>		
<p>Yellow Wrench with Red Battery "Hazard" Symbol</p>		<p>The Power Module Backup battery is not functioning properly or it is not installed. See Figure 3.27.</p>
<p><i>accompanied by a continuous audio tone</i></p>		

Table 3.1 Charge Status Indicators for the Power Module Backup Battery



Power Module backup battery is charged when battery symbol is green

Figure 3.24 Green Charge Symbol Indicates that the Power Module Backup Battery is Charged



Power Module backup battery is charging when battery symbol is yellow

Figure 3.25 Yellow Charge Symbol Indicates that the Power Module Backup Battery is Charging

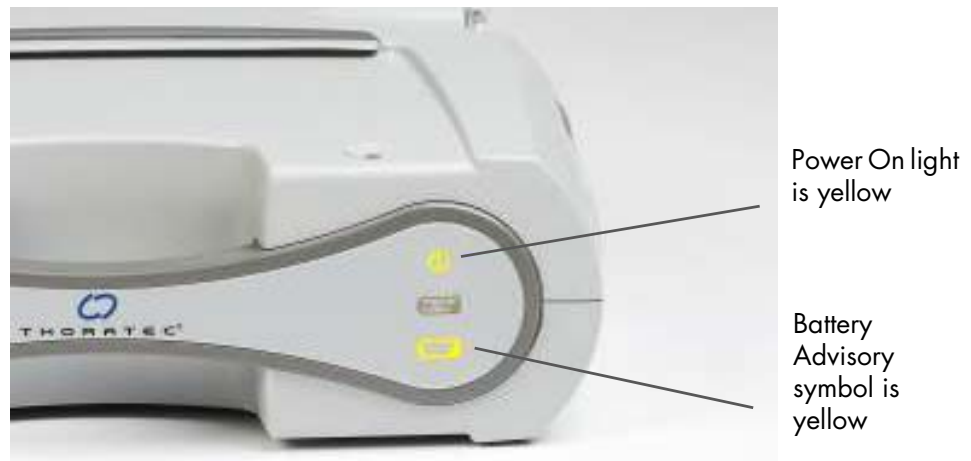

Figure 3.26 Less than 15 Minutes of Power Module Backup Power Remain When Power On Light and Battery Advisory Symbol are Yellow

WARNING !

If the Wrench Malfunction symbol illuminates yellow and the Battery Hazard symbol illuminates red (**Figure 3.27**), switch to another Power Source immediately.



Figure 3.27 Yellow Wrench and Red Battery Hazard Symbol Indicate that the Power Module Backup Battery is Not Working— Switch to Another Power Source Immediately

The Power Module is shipped with the Power Module backup battery not installed. If the Power Module backup battery is not installed or connected when the Power Module is plugged in, the Power Module alarms, indicating that it cannot provide backup power in the event of a power interruption or failure.

When the Power Module alarms, a continuous audio tone sounds and the yellow wrench and red battery symbols illuminate. To clear the alarm, first disconnect the Power Module from AC power and then connect the internal backup battery according to instructions in *Installing the Power Module Backup Battery* on page 3-8.

Storing and Shipping the Power Module

If the Power Module is without electrical power for approximately 18 hours or more, the internal backup battery may be damaged. If the Power Module is not being used and will be unplugged from electrical power for an extended time, such as for transport for service or maintenance, the Power Module backup battery must be disconnected to prevent damage to the battery.

Disconnecting the Power Module Backup Battery

The Power Module backup battery should be disconnected any time the Power Module is unplugged for an extended period, such as when the Power Module is shipped for service or during extended periods of time without AC. In these situations, the battery remains in the battery compartment but is not connected.

FOR THIS TASK YOU NEED:

- 1 Power Module backup battery installed and connected
- 1 crosshead (Phillips) screwdriver

TO DISCONNECT THE POWER MODULE BACKUP BATTERY:

1. Place the Power Module on a flat, stable surface. Make sure the Power Module is unplugged from AC power and disconnected from the patient. Transfer the patient to battery power prior to disconnecting.
2. Inspect the Power Module for dents, chips, cracks, or other signs of damage. Do not use a Power Module that appears damaged. Contact Abbott for a replacement, if needed.
3. Use a crosshead (Phillips) screwdriver to loosen the two ¼-turn screws from the rear panel. The screws remain in the screw holes to ensure they are not lost (**Figure 3.28**).



Figure 3.28 Loosen the Screws

4. Open the battery compartment cover on the rear of the Power Module (**Figure 3.29**).



Figure 3.29 Remove the Battery Compartment Cover

5. Leave the metal bracket and black clip in place, and use your finger to gently pull the wires and white connectors out away from the battery (**Figure 3.30**).



Figure 3.30 Gently Pull the Wires and Connectors Away

6. Gently squeeze the white latch on the connector to free the two halves. Pull the connector halves away from each other to disconnect (**Figure 3.31**).



Figure 3.31 Gently Squeeze the Latch

Note: The Power Module alarms (audio and visual) indicating that the unit is disconnected from AC power. To silence the alarm, press the silence alarm button (☒) on the user panel. The alarm clears when AC power is applied to the Power Module.

7. Gently fold the wires and white connector along the top of the battery and over the metal bracket screws (**Figure 3.32**).



Figure 3.32 Gently Fold the Wires and Connector Along the Top

8. Replace the battery compartment cover.
9. Use the crosshead (Phillips) screwdriver to tighten the two $\frac{1}{4}$ -turn screws. Make sure the screws are tight and the cover is securely closed (**Figure 3.33**).



Figure 3.33 Tighten the Screws

Reconnecting the Power Module Backup Battery

Make sure you reconnect the Power Module backup battery any time it may have been disconnected, such as for annual maintenance.

FOR THIS TASK YOU NEED:

- 1 Power Module backup battery installed but not connected
- 1 crosshead (Phillips) screwdriver

TO RECONNECT THE POWER MODULE BACKUP BATTERY:

1. Place the Power Module on a flat, stable surface.
2. Inspect the Power Module for dents, chips, cracks, or other signs of damage. Do not use a Power Module that appears damaged. Contact Abbott for a replacement, if needed.
3. Use a crosshead (Phillips) screwdriver to loosen the two ¼-turn screws from the rear panel. The screws remain in the screw holes to ensure they are not lost (**Figure 3.34**).



Figure 3.34 Loosen the Screws

4. Open the battery compartment cover on the rear of the Power Module (**Figure 3.35**).



Figure 3.35 Remove the Battery Compartment Cover

5. Leave the metal bracket and black clip in place, and use your finger to gently pull the wires and the two halves of the white connector out of the battery compartment (**Figure 3.36**).



Figure 3.36 Gently Pull the Wires and Connector Halves Out

6. Line up the two connector halves (**Figure 3.37**).



Figure 3.37 Line Up the Connector Halves

7. Firmly press the halves together. You should hear a click when the connector is fully engaged.
8. Gently fold the wires and white connector along the top of the battery and over the metal bracket screws (**Figure 3.38**).



Figure 3.38 Gently Fold the Wires and Connector Along the Top

9. Replace the battery compartment cover.

10. Use the crosshead (Phillips) screwdriver to tighten the two $\frac{1}{4}$ -turn screws. Make sure the screws are tight and the cover is securely closed (**Figure 3.39**).



Figure 3.39 Tighten the Screws

Silencing Power Module Alarms

Press the silence alarm button () to silence a Power Module audio alarm.

See **Table 3.2** for information about how long an alarm is silenced—silence periods vary by alarm type. After the silence period ends, the audio alarm resumes unless the alarm condition has been resolved. If a new alarm condition arises during a silence period, a new audio alarm sounds.

IMPORTANT! Pressing the silence alarm button only silences the alarm. The alarm condition is not resolved as indicated by persistence of the visual alarm.

Audio Alarm	How Long Alarm is Silenced
Echo System Controller alarm	5 minutes.
AC Fail	Silence lasts until cancelled by another alarm, such as yellow battery.
Yellow Battery	8 hours or until cancelled by another alarm, such as red battery.
Red Battery	Alarm cannot be silenced if patient is connected to pump.
Yellow Wrench (Advisory)	8 hours.
Yellow Wrench (Hazard/Critical)	8 hours for non-critical faults. Alarm cannot be silenced if patient is connected to pump.

Table 3.2 Audio Alarm Silence Periods

Caring for the Power Module

See *Cleaning and Maintenance* on page 8-4 for warnings, cautions, and instructions on caring for the Power Module.

Using the Mobile Power Unit

The Mobile Power Unit (**Figure 3.40**):

- Provides power to the System Controller and pump.
- Powers the system while the patient is sleeping or relaxing indoors.
- Echoes System Controller alarms.



Figure 3.40 The Mobile Power Unit

WARNING !

- Care should be taken when small children or pets are present. There is a potential for strangulation from the system's cables.
- The Mobile Power Unit radiates radio frequency energy. If not used according to instructions, the Mobile Power Unit may cause harmful interference with nearby devices. To confirm interference, switch to battery power, and then unplug the Mobile Power Unit and observe the effect on devices in the area. If interference is detected, switch to another power source and then:
 - Re-orient or move the affected devices.
 - Increase the distance between the Mobile Power Unit and the affected devices.
 - Connect the affected devices to an electrical outlet different from the outlet used to power the Mobile Power Unit.
- The patient must always connect to the Mobile Power Unit when sleeping, or when there is a chance of sleep. A sleeping patient may not hear system alarms; the Mobile Power Unit echoes the alarms.
- Do not connect a System Controller to both the Mobile Power Unit and the Power Module at the same time, or damage to the System Controller and injury to the patient may occur. First connect to HeartMate 14 Volt batteries.
- If there is a power failure, transfer the patient from the Mobile Power Unit to another power source. The backup battery in the System Controller will temporarily power the pump while you transfer to batteries. Do not rely on the System Controller's backup battery as a power source during AC power failure, as it will only power the pump for a limited amount of time and the pump will stop (see *Switching Power Sources* on page 3-66).
- Keep the Mobile Power Unit dry and away from water or liquid. If the Mobile Power Unit comes into contact with water or liquid, it may fail to operate properly or you may get an electric shock.
- Do not use the Mobile Power Unit in the presence of a flammable anesthetic mixture with air or with oxygen or nitrous oxide, or an explosion could occur.
- High levels of static electricity may damage or harm the system and may cause the pump to stop. When not sleeping or resting, it is recommended that the patient use battery power instead of the Mobile Power Unit to power the system. Using battery power can reduce the risk of system damage from high levels of static electricity.

CAUTION !

- To avoid the risk of electric shock, plug the Mobile Power Unit into a properly-tested AC electrical outlet that is dedicated to Mobile Power Unit use. Do not use portable, multiple outlet (power strip) adapters or extension cords.
- Avoid covering the Mobile Power Unit, such as with a blanket. Covering the Mobile Power Unit may reduce the ability to hear important system alarms or may cause the Mobile Power Unit to fail due to overheating.
- When connecting power cable connectors, do not try to join them together without first aligning the half circles inside the connectors. Joining together misaligned power cable connectors may damage them.
- At least one System Controller power cable must be connected to a power source (the Power Module, Mobile Power Unit, or two HeartMate 14 Volt Lithium-Ion batteries) at all times. Do not rely on the System Controller's backup battery, as it will only power the pump for a limited amount of time.
- Do not use the Mobile Power Unit with DC to AC inverters, as they may cause the Mobile Power Unit to fail.
- Do not connect the Mobile Power Unit to electrical outlets that are controlled by a wall switch, as the Mobile Power Unit will fail to supply power.
- Avoid positioning the Mobile Power Unit where access to the power cord plug into the wall socket is limited or where disconnection of the plug from the wall socket is difficult.
- The Mobile Power Unit has an AC Power Cord and Patient Cable, both of which may be a tripping hazard. Ensure that the patient, care givers, and all other persons near the Mobile Power Unit are aware of this potential hazard.
- Do not clean or service the Mobile Power Unit while it is plugged into an AC electrical outlet, or electrical shock may occur.
- Do not incinerate, disassemble, crush, puncture, or otherwise damage batteries, as this can cause leakage or rupture, resulting in personal injury or damage to the Mobile Power Unit.
- Do not mix old and new alkaline batteries or battery types (such as rechargeable and non-rechargeable), as this can cause leakage or rupture, resulting in personal injury or damage to the Mobile Power Unit.
- Mobile Power Unit power output may be affected by mobile phones, resulting in low power alarms on the System Controller, or loss of the green power LED on the Mobile Power Unit. If either of these conditions is observed, separate the mobile phone from the Mobile Power Unit by at least .6 meters (24 inches). If the condition persists after separating the devices, switch to two HeartMate 14 Volt Lithium-Ion batteries.

CAUTION ! (Continued)

- Keep the Mobile Power Unit free of excessive lint and dust. Also, keep the Mobile Power Unit away from heat or humidity sources, such as a fireplace, radiant heater, nebulizer, or steam kettle. The Mobile Power Unit may fail to operate properly due to excessive lint, dust, heat, or humidity.
- Inspect the Mobile Power Unit patient and power cables for damage. Do not use the Mobile Power Unit if either cable shows signs of damage.
- When moving the Mobile Power Unit to a different location or AC power source, first connect the System Controller to HeartMate 14 Volt batteries.
- Do not change the Mobile Power Unit batteries while the Mobile Power Unit is powering the HeartMate system. Prior to replacing the Mobile Power Unit batteries, switch to another power source. Then disconnect the Mobile Power Unit power cord from the wall socket.
- Do not carry or touch the Mobile Power Unit for an extended time. To avoid the risk of burns, do not touch the top surface of the Mobile Power Unit for longer than one minute. The Mobile Power Unit surface temperature can become uncomfortably warm, especially when the room temperature is above 104°F (40°C). Surface temperatures can approach 131°F (55°C).

Mobile Power Unit User Interface Components

The buttons, lights, symbols, and display screen on the Mobile Power Unit user interface are introduced below in **Table 3.1**. Additional details follow after the table.



<p>Power On Symbol</p> 	<p>The power symbol is illuminated green when the Mobile Power Unit is powered and functioning properly.</p>
<p>Yellow Wrench Alarm</p> 	<p>The yellow wrench symbol illuminates when the Mobile Power Unit detects a mechanical, electrical, or software issue with the system.</p> <p>This is an Advisory alarm. When the yellow wrench illuminates, switch to two fully-charged HeartMate 14 Volt Lithium-Ion batteries.</p> <p>For more information, see page 7-40.</p>
<p>Replace Mobile Power Unit Battery Alarm</p> 	<p>The yellow Replace Mobile Power Unit Battery symbol illuminates when the Alkaline AA batteries are not installed, or are depleted and need replaced.</p> <p>This is an Advisory alarm. When the Replace Mobile Power Unit Battery symbol illuminates, replace the internal batteries in the Mobile Power Unit.</p> <p>For more information, see page 7-40.</p>

Table 3.1 Mobile Power Unit User Interface Components

Setting Up the Mobile Power Unit For Use

To set up the Mobile Power Unit, perform these tasks:

- Install the Mobile Power Unit batteries.
- Connect the Mobile Power Unit power cord to the Mobile Power Unit and AC power.

Installing or Replacing the Mobile Power Unit Batteries

The Mobile Power Unit uses three Alkaline AA batteries to power its alarms only. You must install the Mobile Power Unit batteries before using the Mobile Power Unit. The batteries power the alarm echo function when an AC power failure occurs or the power cord is disconnected.

The yellow Mobile Power Unit battery symbol  illuminates and a beeping audio tone sounds when the Alkaline AA batteries are not installed, or when the batteries are depleted and need replaced.

CAUTION !

Never change the Mobile Power Unit batteries while the Mobile Power Unit is powering the HeartMate system. Switch to another power source, and then disconnect the Mobile Power Unit power cord from the power socket prior to replacing the batteries.

FOR THIS TASK YOU NEED:

- Mobile Power Unit
- 3 fresh Alkaline AA batteries
- Flathead screwdriver or coin

TO INSTALL OR REPLACE THE MOBILE POWER UNIT BATTERIES:

1. Place the Mobile Power Unit on a flat, sturdy surface.
2. Ensure that the power cord is unplugged from the Mobile Power Unit.
3. Inspect the Mobile Power Unit for dents, chips, cracks, or other signs of damage. Do not use a Mobile Power Unit that appears damaged. Contact Abbott for a replacement, if needed.

4. Use a flathead screwdriver or coin to loosen the screw from the rear panel. The screw remains in the screw hole to ensure it is not lost (**Figure 3.41**).



Figure 3.41 Loosen the Screw

5. Open the battery compartment cover on the rear of the Mobile Power Unit (**Figure 3.42**). Remove and dispose of the battery installation reminder tag, if present.



Figure 3.42 Remove the Battery Compartment Cover

6. If replacing batteries, gently pull the ribbon to remove the depleted batteries from the case.

7. Place the Alkaline AA batteries in the battery compartment. Follow the orientation markings on the battery clip when inserting the batteries (**Figure 3.43**).



Figure 3.43 Install AA Batteries

8. Replace the battery compartment cover.
9. Use the flathead screwdriver or coin to tighten the screw. Make sure the screw is tight and the cover is securely closed (**Figure 3.44**).



Figure 3.44 Tighten the Screw

10. Dispose of or recycle the depleted batteries in compliance with all applicable local, state, and federal regulations.

Connecting the Power Cord

FOR THIS TASK YOU NEED:

- Mobile Power Unit (with 3 AA batteries installed)
- Mobile Power Unit power cord
- Functioning AC electrical outlet that is dedicated to Mobile Power Unit use and not controlled by a wall switch

TO CONNECT THE POWER CORD:

1. Place the Mobile Power Unit on a flat, sturdy surface.
2. Plug the power cord into the Mobile Power Unit (**Figure 3.45**).



Figure 3.45 Plug Power Cord into Mobile Power Unit

3. Pull back on the end of the power cord to ensure a secure connection to the Mobile Power Unit (**Figure 3.46**).



Figure 3.46 Pull Back to Ensure Secure Connection

4. Plug the Mobile Power Unit into an AC electrical outlet that is dedicated to Mobile Power Unit use.

CAUTION !

- Do not use an outlet that is controlled by a wall switch.
- Do not use an adapter; a portable, multiple outlet power strip; a ground fault interrupter (GFI); or a residual current device (RCD) outlet.

5. Observe the top panel of the Mobile Power Unit.

When initially connected to power, the Mobile Power Unit automatically performs a self test during which the green "Power On" light turns on. The yellow wrench and the Replace Mobile Power Unit Battery lights flash and the Mobile Power Unit beeps twice. After the self test is completed, the green "Power On" light remains illuminated

(Figure 3.47). If this behavior is not observed, contact Abbott.

For Abbott contact information, see the *Back Cover* of this manual.



Figure 3.47 Mobile Power Unit Ready for Use

Note: If the green "Power On" light does not come on, plug the power cord into another electrical outlet. If the green light still does not come on, the Mobile Power Unit may have a problem. Do not use a defective device. Contact Abbott for a replacement, if needed.

IMPORTANT! The power symbol (🔌) is illuminated green when the Mobile Power Unit is powered and functioning properly.

WARNING !

- For international travel, the patient needs a Abbott power cord. The power cord must be compatible with the local voltage, and meet applicable national plug, rated voltage, rated current, and safety agency marks and specifications. Contact Abbott for a power cord, if needed. Refer to the *Back Cover* of this manual for Abbott contact information.
- If traveling by aircraft, the patient should be instructed to bring sufficient battery power to power the system until the destination is reached. Neither the Mobile Power Unit nor the Battery Charger should be used on aircraft.

Disconnecting the Power Cord

FOR THIS TASK YOU NEED:

- Mobile Power Unit
- Black AC power cord connected to the Mobile Power Unit.

TO DISCONNECT THE V-LOCK POWER CORD:

1. Place the Mobile Power Unit on a flat, sturdy surface.
2. Press down and hold the yellow button on the top of the plug to disengage the locking mechanism (**Figure 3.48**).
3. Pull out and unplug the power cord from the Mobile Power Unit.

Figure 3.48 Press Yellow Locking Button Down and Pull Out

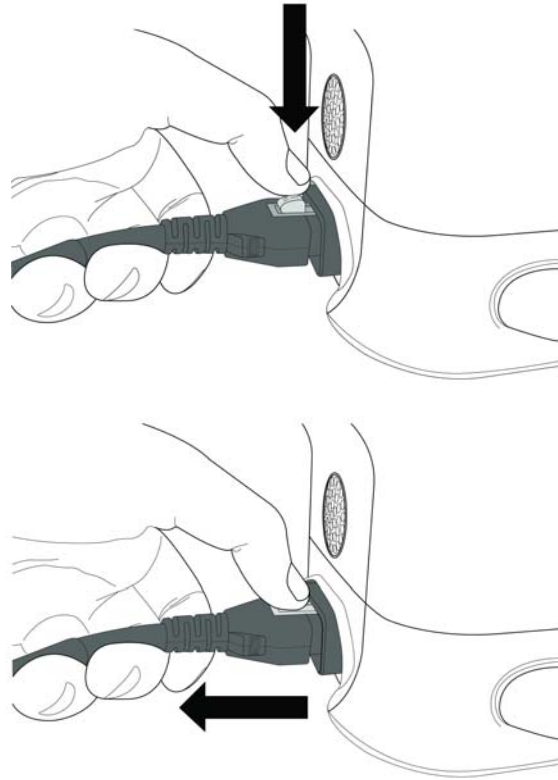

When to Connect to the Mobile Power Unit

Connect the System Controller to the Mobile Power Unit when the patient is stationary or relaxing indoors. Do not use the Mobile Power Unit when the patient may require monitoring using the HeartMate Touch™ Communication System. Patients must always connect to the Mobile Power Unit before sleeping (or when sleep is likely), because they may not awaken to hear low power alarms for batteries (see *System Controller Alarms* on page 7-2).

The Mobile Power Unit patient cable (**Figure 3.49**) connects the System Controller to the Mobile Power Unit.



Figure 3.49 Mobile Power Unit Patient Cable

CAUTION !

Do not allow the cable to come into contact with sharp edges, and use care to prevent it from being pinched or bent.

Like the power cable connectors on the System Controller, the connectors on the Mobile Power Unit patient cable are also color coded (see **Figure 3.49**). When connecting the System Controller to the Mobile Power Unit patient cable, always connect white-to-white and black-to-black.

FOR THIS TASK YOU NEED:

- Running System Controller
- Working Mobile Power Unit that is ready for use
- Working Mobile Power Unit patient cable

TO CONNECT THE SYSTEM CONTROLLER TO THE MOBILE POWER UNIT:

1. Gather equipment.
2. Confirm that the Mobile Power Unit is ready for use (see *Setting Up the Mobile Power Unit For Use* on page 3-39).
3. Place the black and white System Controller power cable connectors within easy reach (**Figure 3.50**).



Figure 3.50 System Controller Power Cable Connectors

4. Place the black and white Mobile Power Unit patient cable within easy reach.
5. From battery power:
 - a. Place the batteries with their attached battery clips within easy reach.
 - b. Unscrew and disconnect only the white System Controller power cable connector from the attached battery clip. Do not remove the black connector!

- c. Promptly align opposite half circles inside the white System Controller power cable connector and the white Mobile Power Unit patient cable connector (**Figure 3.51**).

CAUTION !

Do not try to join together misaligned connectors. Doing so can damage them.



Figure 3.51 Carefully Align the Connectors

- d. Firmly push together the two connectors (**Figure 3.52**).

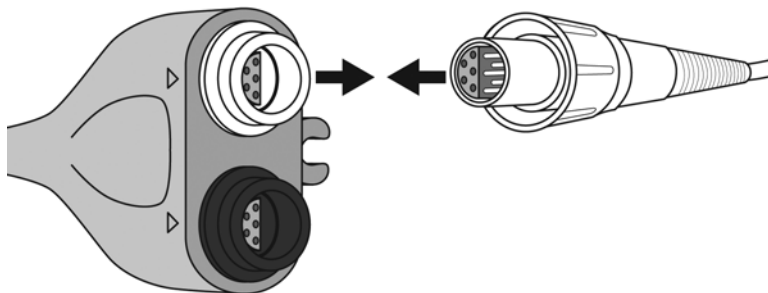

Figure 3.52 Push Together the Two Connectors

- e. Tighten the connector nut until secure (**Figure 3.53**). Hand tighten only—do not use tools.



Figure 3.53 Tighten the Connector Nut

- f. Unscrew and disconnect only the black System Controller power cable connector from the attached battery clip.
- g. Promptly align opposite half circles inside the black System Controller power cable connector and the black Mobile Power Unit patient cable connector.

CAUTION !

Do not try to join together misaligned connectors. Doing so can damage them.

- h. Firmly push together the two connectors.
- i. Tighten the connector nut until secure. Hand tighten only—do not use tools.

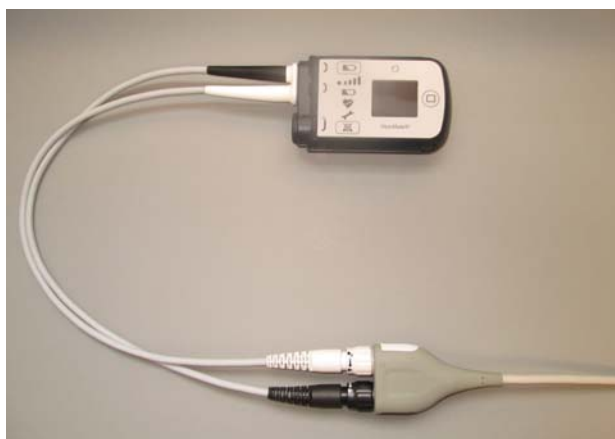

Figure 3.54 System Controller Power Cables Connected to Mobile Power Unit Patient Cable Connectors

Mobile Power Unit Storage

If the Mobile Power Unit will not be used for an extended time, unplug the AC power cord from power and detach the power cord from the device. Wrap the Mobile Power Unit patient cable around the Mobile Power Unit for storage (**Figure 3.55**). This also a convenient way to prepare the device and patient cable for travel.



Figure 3.55 Storing the Mobile Power Unit

Caring for the Mobile Power Unit

The Mobile Power Unit requires little planned maintenance. However, it should be inspected routinely to ensure the safest and best possible performance. For complete information about caring for the Mobile Power Unit, see *Caring for the Power Module and Mobile Power Unit* on page 8-7.

IMPORTANT! Periodically, and as needed, use a clean, damp (not wet) cloth to clean the exterior surfaces of the Mobile Power Unit. You may use a mild detergent, if necessary.

WARNING !

- Unplug all connections before cleaning the Mobile Power Unit.
- Do not put the Mobile Power Unit into water or liquid.
- Never clean the Mobile Power Unit while it is providing power to the Pump. Switch to another power source before cleaning the Mobile Power Unit.

Using HeartMate 14 Volt Lithium-Ion Batteries

Using battery power for the HeartMate 3 Left Ventricular Assist System allows for greater patient mobility than when connected to the Power Module or Mobile Power Unit. On battery power, patients can enjoy activities outdoors or away from home such as shopping, gardening, or running errands. A pair of HeartMate 14 Volt Lithium-Ion batteries (**Figure 3.56**) provides direct current (DC) to the pump. Both batteries are discharged together (not one, then the other).



Figure 3.56 HeartMate 14 Volt Lithium-Ion Battery

Each battery is inserted into a 14 Volt battery clip (**Figure 3.57**). The batteries and attached battery clips can be worn in holsters, one under each arm, or across the body, in a bag, or in a pouch around the waist. The battery clips transfer power from the batteries to the System Controller. Their use is required with the batteries.



Figure 3.57 Inserting Battery into Battery Clip

During battery-powered operation, the System Controller battery power gauge shows overall power capacity for both batteries (see *Performing a System Controller Self Test* on page 2-29). The System Controller's battery power gauge indicates when the batteries are low and prompts the switch to a different power source (the Power Module, Mobile Power Unit, or a new, fully-charged pair of HeartMate 14 Volt Lithium-Ion batteries). The status of an individual battery can be checked at any time by pressing the on-battery power gauge on the individual battery (see *Checking Battery Charge Status Using the On-Battery Power Gauge* on page 3-56).

Required Components

Components for operating the HeartMate 3™ system on battery power include the following:

- 2 fully-charged HeartMate™ 14 Volt Lithium-Ion batteries
- 2 compatible 14 Volt battery clips

In addition, the System Controller must be connected to the Left Ventricular Assist Device via the Driveline.

IMPORTANT! HeartMate batteries only work in matching pairs with matching compatible clips.

The HeartMate 3 Left Ventricular Assist System is optimized for operation with two batteries, but the system can run on only one battery for a very short period (minutes). For example, when switching from batteries to the Power Module or Mobile Power Unit (or vice versa), operation will continue on a single battery while connections are made.

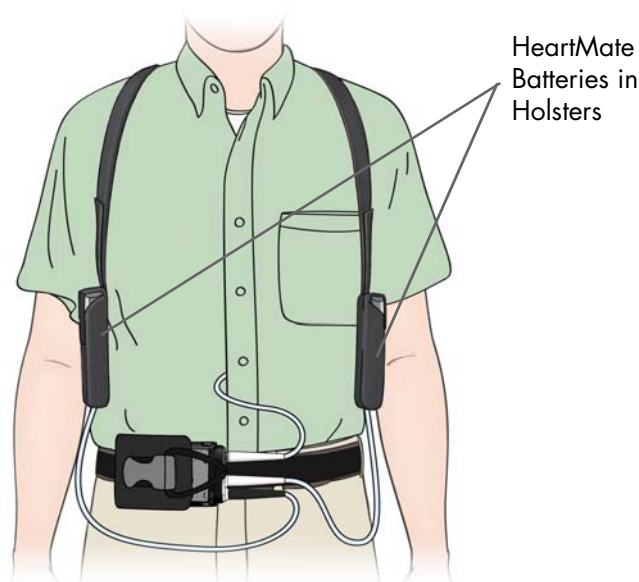

Figure 3.58 HeartMate Batteries Worn in Holsters

WARNING !

- Use only HeartMate 14 Volt Lithium-Ion batteries supplied by Abbott with the HeartMate 3 Left Ventricular Assist System. Using the wrong batteries may cause the Pump to stop.
- HeartMate 14 Volt Lithium-Ion batteries must be charged before use. Before removing a battery from the Battery Charger, make sure that the battery has completed its charge or calibration cycle. After removing the battery from the Battery Charger, use the battery power gauge that is on the battery to check the battery's charge level.
- Use only Abbott-supplied 14 Volt battery clips with HeartMate 14 Volt Lithium-Ion batteries. Other clips will not transfer electrical power to the system.
- Do not use batteries to power the system when the patient is sleeping. The patient must always connect to the Power Module or Mobile Power Unit for sleeping or when there is a chance of sleep. A sleeping patient may not hear the System Controller alarms.
- At least one System Controller power cable must be connected to a power source (Power Module, Mobile Power Unit, or two HeartMate 14 Volt Lithium-Ion batteries) at all times.
- Do not use damaged, defective, or expired batteries. Using damaged, defective, or expired batteries may reduce operating time or the pump may stop.
- If traveling by aircraft, the patient should be instructed to bring sufficient battery power to power the system until the destination is reached. Neither the Mobile Power Unit nor the Battery Charger should be used on aircraft.

CAUTION !

- Use only the Abbott-supplied Battery Charger to charge HeartMate 14 Volt Lithium-Ion batteries. Other battery chargers may damage HeartMate batteries.
- Calibrate a battery as soon as possible after being prompted, to prevent a backlog of uncalibrated batteries. After approximately 70 uses, HeartMate 14 Volt Lithium-Ion batteries may need to be recalibrated. The Battery Charger indicates when a battery needs to be calibrated. Calibration can take up to 12 hours, and only one battery can be calibrated at a time.
- Leave a calibrating 14 Volt Lithium-Ion battery in the Battery Charger for the full calibration cycle. Removing a battery before it is fully calibrated may result in a depleted battery. The on-battery power gauge will reflect this status.
- Clean the metal contacts on the batteries and inside the battery clips at least once a month. Dirty battery contacts on the 14 Volt Lithium-Ion battery may prevent proper charging, which can affect operation. Use a lint-free cloth or cotton swab that has been moistened (not dripping) with rubbing alcohol. Let the alcohol dry before using the batteries or battery clips, or before placing batteries into the Battery Charger.
- As 14 Volt Lithium-Ion batteries get older, they support the left ventricular assist system for shorter periods of time. If batteries do not give at least four hours of support, take them out of service.
- After 360 cycles/36 months, battery performance cannot be guaranteed and batteries should be replaced. If stored and used within recommended guidelines, HeartMate 14 Volt Lithium-Ion batteries should be usable for approximately 360 use/charge cycles or for 36 months from the date of manufacture, whichever comes first.
- If a 14 Volt Lithium-Ion battery leaks, do not touch the leaking fluid. If the fluid touches your skin or eyes, wash the affected area with plenty of water and seek medical advice.

CAUTION ! (Continued)

- To prevent deterioration or damage to a 14 Volt Lithium-Ion battery:
 - Do not store in direct sunlight.
 - Store within approved temperatures: 14°F to 104°F (-10°C to 40°C). See *Storage and Transport* on page 8-2 for complete storage guidelines, including great than 30 days.
 - Do not use in temperatures that are below 32°F (0°C) or above 104°F (40°C) or the battery may fail suddenly.
 - Do not dismantle, open, or shred.
 - Do not drop or hit hard objects or each other.
 - Do not leave or store in extremely hot or cold temperatures, such as in automobiles or automobile trunks, or battery life will be shortened.
 - Do not expose to heat or fire.
 - Do not store batteries together with keys, coins, or other loose metallic objects. Metal objects touching the exposed battery contacts may cause an accidental short and a rapid discharge of the battery. This can result in battery overheating that may burn you or damage the batteries.
- Keep batteries out of the reach of children.
- Keep batteries clean and dry.
- Dispose of or recycle an expired battery in accordance with local, state, and federal regulations.

Charging a New HeartMate Battery Before Use

Every HeartMate 14 Volt Lithium-Ion battery must be charged before being used for the first time. It takes up to four hours to charge a new battery, depending on the initial charge status of the battery. Batteries are charged in the Battery Charger, which can charge up to four batteries simultaneously. Charging a battery in the Battery Charger is described in more detail in *Charging HeartMate Batteries* on page 3-80.

Checking Battery Charge Status Using the On-Battery Power Gauge

After a HeartMate battery is charged, it should be ready for use. Make sure it has finished charging, and then use the on-battery power gauge to confirm that the battery is fully charged.



Figure 3.59 Press the Battery Symbol on the Battery to Use the On-Battery Power Gauge

The on-battery power gauge on a HeartMate battery uses five green bars to show available battery power (**Figure 3.60**). Each bar represents approximately 20% of available power. When a battery is fully charged, all five bars light up when you press the power gauge button, indicating that the battery is 80–100% charged. Fewer bars illuminate as power is depleted. When battery power drops below 10%, only one green blinking bar comes on.

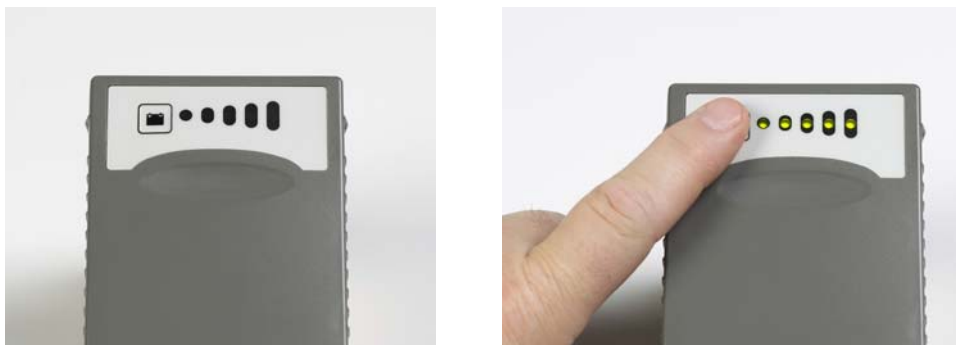

Figure 3.60 On-Battery Power Gauge: Press Battery Symbol to Activate Bars

FOR THIS TASK YOU NEED:

- 1 HeartMate 14 Volt Lithium-Ion battery
- Battery charger

TO CHECK A BATTERY'S CHARGE STATUS USING THE BATTERY POWER GAUGE:

1. Obtain a battery from one of the Battery Charger charging pockets.
2. Look at the lights next to the charging pocket for the battery. A green light on the charger means that the battery is charged and ready for use.
3. Remove the battery from the charging pocket.
4. Find the battery symbol on the battery's power gauge.
5. Press and hold the battery symbol for five seconds.
6. If all five green power gauge bars light, the battery is between 80–100% charged.

OR

7. If four or fewer bars light, the battery is not fully charged. Return it to the pocket for more charging. If the power gauge continues to show four or fewer bars after additional charging, the battery may be defective—do not use it. Contact Abbott for a replacement, if needed.

The table below describes the on-battery power gauge on a 14 Volt Lithium-Ion battery (see **Table 3.2**).







<p>No bars</p> 	<p>Battery is in "sleep" mode, due to being in storage for a long period of time. Charge battery immediately.</p>
<p>1 bar (blinking)</p> 	<p>Approximately 10% or less of power remains. Do not use if battery has one blinking bar.</p>
<p>1 bar (steady)</p> 	<p>Approximately 10–20% of power remains.</p>
<p>2 bars</p> 	<p>Approximately 20–40% of power remains.</p>
<p>3 bars</p> 	<p>Approximately 40–60% of power remains.</p>
<p>4 bars</p> 	<p>Approximately 60–80% of power remains.</p>
<p>5 bars</p> 	<p>Approximately 80–100% of power remains.</p>

Table 3.2 14 Volt Lithium-Ion Battery On-Battery Power Gauge

A battery's power gauge may show five bars illuminated, while the Battery Charger indicates a "charging yellow" light. This is normal, because five bars on the battery does not indicate "fully charged," but rather 80–100% charged.

IMPORTANT! A green light next to the battery charger pocket is the only assurance that a battery in the charger is 100% charged. If the yellow light next to the pocket is on, the battery is still charging. If the red light next to the pocket is on, the battery has a problem—do not use it.

If all of the power gauge bars come on except for one in the middle of the sequence, the light emitting diode (LED) for the bar may be broken or burned out. If this happens, please contact Abbott. For Abbott contact information, see the *Back Cover* of this manual.

IMPORTANT! Depending on how long a battery has been in storage, its power gauge may not work until after the battery undergoes its first charge.

When to Connect to Batteries

Connect the System Controller to battery power when patients are active and mobile, outdoors, or when AC electricity fails or is unavailable. For more information, see *Using HeartMate 14 Volt Lithium-Ion Batteries* on page 3-51.

FOR THIS TASK YOU NEED:

- Running System Controller
- Two charged and working HeartMate 14 Volt Lithium-Ion batteries (see *Charging HeartMate Batteries* on page 3-80)
- Two HeartMate 14 Volt Lithium-Ion battery clips
- One battery holster or other accessory for holding or carrying in-use batteries

TO CONNECT THE SYSTEM CONTROLLER TO 14 VOLT BATTERIES:

1. Gather equipment.
2. Insert a charged HeartMate 14 Volt Lithium-Ion battery into each 14 Volt battery clip (see *Using HeartMate 14 Volt Lithium-Ion Batteries* on page 3-51).
3. Place the batteries with attached battery clips within reach.

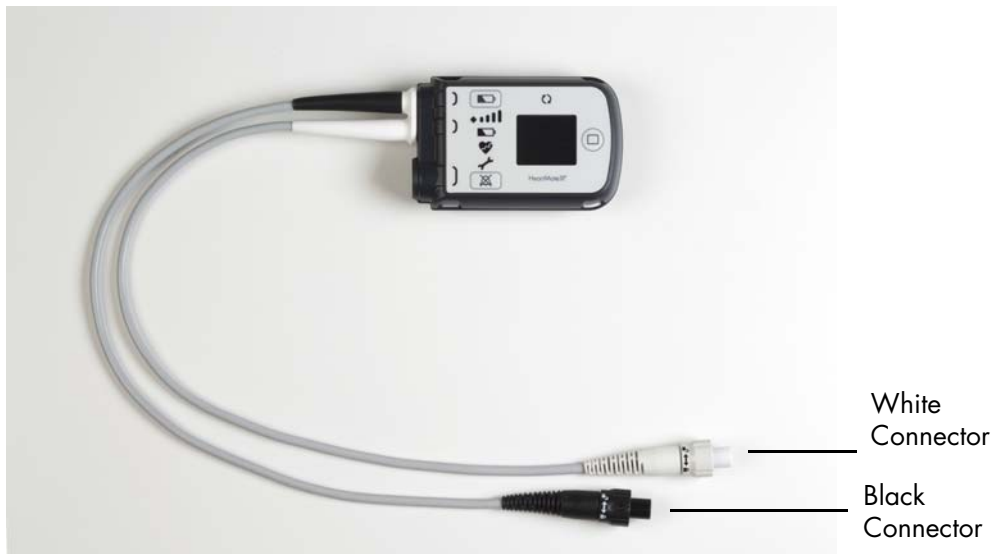

Figure 3.61 Black and White System Controller Power Cable Connectors

4. Place the black and white System Controller power cable connectors within reach (**Figure 3.61**).

5. Unscrew and disconnect only the white System Controller power cable connector from its current power source.

WARNING !

Do not disconnect the other connector.

6. Align the opposite half circles inside the white System Controller power cable connector and the power cable connector for one of the battery clips (**Figure 3.62**).

CAUTION !

Do not try to join together misaligned connectors. Doing so can damage them.

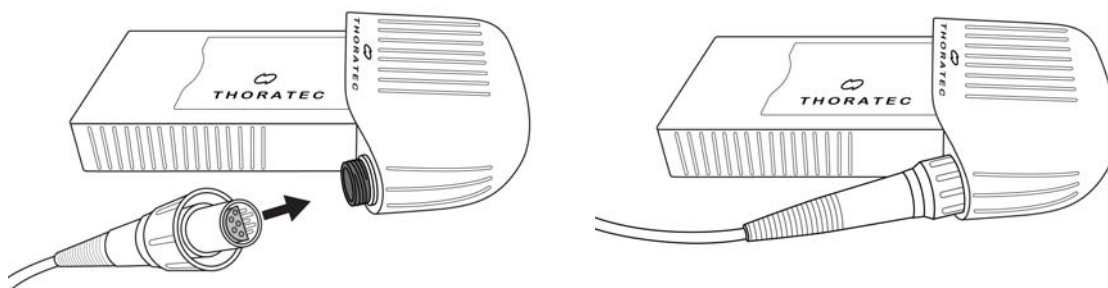

Figure 3.62 Align the Half Circles on the Connectors

7. Firmly push together the two connectors.
8. Securely hand tighten the connector nut. Do not use tools.
9. Repeat Steps 5 through 8 for the black System Controller power cable connector and the second battery clip connector.



Figure 3.63 System Controller Power Cables Connected to Battery Clips

Estimating Remaining Time for In-Use Batteries

When approximately 15 minutes of battery power are left, the System Controller initiates a Low Battery Power **Advisory** alarm, which is indicated by the following:

- Flashing yellow diamond on the System Controller's user interface.
- "Low Battery" and "Replace Power" alternate on the user interface screen.
- Alarm tone: slow beep.

When approximately five minutes of operation remain, the System Controller initiates a Low Battery Power **Hazard** alarm, which is indicated by the following:

- Flashing red battery on the System Controller's user interface.
- "Low Battery" and "Replace Power Immediately" alternate on the user interface screen.
- Alarm tone: constant tone.

The Low Battery Power Hazard Alarm requires an immediate response. See *System Controller Alarms* on page 7-2 for detailed instructions on responding to System Controller alarms.

During a Low Battery Power Hazard Alarm, the system reverts to power saver mode and gradually ramps down to the low speed setting. If the fixed speed setting is lower than the low speed limit, the pump remains at the lower speed setting.

The Left Ventricular Assist System remains in power saver mode until a new pair of fully-charged batteries are installed, or until the System Controller is connected to the Power Module, Mobile Power Unit, or until no further power remains.

When adequate power is supplied, the pump reverts to the previous mode and speed, and the red battery alarm clears.

Replacing Depleted Batteries

FOR THIS TASK YOU NEED:

- 1 running System Controller
- 2 in-use HeartMate 14 Volt Lithium-Ion batteries
- 2 14 Volt battery clips
- 2 fully-charged HeartMate 14 Volt Lithium-Ion batteries

TO REPLACE DEPLETED BATTERIES WITH CHARGED BATTERIES:

1. Obtain two charged HeartMate batteries and place them within easy reach. If you remove batteries from the Battery Charger, make sure that the light near the charging pocket for each battery is green, indicating that the battery is charged (see *Charging HeartMate Batteries* on page 3-80).
2. Press and hold the battery symbol on each battery; make sure each battery is charged and ready for use.
3. Grasp the battery clip and attached battery for one of the batteries that is currently powering the system and remove the clip and battery from the holster/carrying case. Do not remove the battery from its clip at this time.
4. Locate the battery power gauge symbol on the battery.
5. Press and hold the battery symbol for five seconds to see how much battery power remains for this battery (ie, count the number of bars that light).
6. Repeat Steps 3–5 for the second battery that is currently in use.
7. Determine which battery has the least power.
8. If both batteries have the same amount of power, replace either battery; otherwise, replace the battery that has the least power first:
 - a. Press the battery release button on the battery clip.
 - b. Withdraw the battery from its clip. The System Controller's Power Cable Disconnected alarm will come on. This is normal.

IMPORTANT! Ensure that a charged battery rather than a depleted battery is used in Step c.

- c. Pick up one of the charged batteries; locate the orange arrow on the battery.

- d. Align the orange arrow on the charged battery with the orange arrow on the battery clip, so the arrows point toward each other (**Figure 3.64**).



Figure 3.64 Align Arrows and Then Insert the Battery in the Clip

- e. Slide the charged battery into the battery clip. The battery should "click" into place. Gently pull on the battery and try to remove it from the clip. If the battery is properly and fully inserted, the battery remains in the clip and the System Controller's power cable disconnected alarm will stop.
 - f. Remove the other depleted battery and repeat Steps a–e.
9. Return the clips and charged batteries to holsters or carrying case.
 10. Make sure the Battery Charger is plugged in and turned on, and then place the depleted batteries in the pockets for recharging.

Wearing and Carrying HeartMate Batteries/Battery Clips

For warnings, cautions, and instructions on wearing and carrying HeartMate batteries, battery clips, and the System Controller, see *Wearing and Carrying System Components* on page 6-26.

Taking Old Batteries Out of Service

One pair of new HeartMate 14 Volt Lithium-Ion batteries provides up to 17 hours of support under nominal operating conditions (pump flows of 5.4 lpm). See *Cleaning and Maintenance* on page 8-4 for information on cleaning and maintaining HeartMate 14 Volt Lithium-Ion batteries and battery clips.

HeartMate 14 Volt Lithium-Ion batteries last for less time if the patient is active or emotionally stressed. As batteries get older, they power the system for shorter periods of time. If a pair of HeartMate batteries does not give at least four hours of support, take both batteries out of service.

A new battery that is stored and used according to the acceptable environmental conditions should be usable for approximately 360 cycles or 36 months from the date of manufacturer, whichever comes first. After this time, battery performance cannot be guaranteed. Call Abbott for a replacement when either of these milestones is reached. See *Storage and Transport* on page 8-2.

The white battery label on each battery contains several safety symbols and the battery's expiration date. The battery may need to be replaced earlier than the expiration date, depending on usage. Batteries should not be used after their expiration date. Dispose of expired batteries according to local, state, and federal regulations. See *Product Disposal* on page 8-11 for information on disposing of HeartMate batteries.

Caring for Batteries and Battery Clips

HeartMate batteries require periodic inspection and cleaning for the most reliable performance. See *Cleaning HeartMate™ 14 Volt Lithium-Ion Batteries and Battery Clips* on page 8-8 for detailed information on inspecting and cleaning batteries and battery clips.

Switching Power Sources

Switching from the Power Module to Battery-Powered Operation

Use care when connecting or disconnecting power cables. For more information, see *Guidelines for Power Cable Connectors* on page 7-45.

FOR THIS TASK YOU NEED:

- 1 running System Controller
- 1 functioning, in-use Power Module
- 1 Power Module power cord
- 2 fully-charged HeartMate 14 Volt Lithium-Ion batteries
- 2 14 Volt battery clips
- 1 battery holster or other wear and carry accessory

TO SWITCH FROM POWER MODULE TO BATTERIES:

1. Place two battery clips, two charged batteries (as indicated by the green light on the Battery Charger), and the white and black Power Module patient cable connectors within easy reach.
2. Place the first charged battery into a battery clip by lining up the arrows on the battery and battery clip and pushing until the battery clicks into place.
3. Repeat Step 2 for the second battery and battery clip.
4. Unscrew the white System Controller and white Power Module patient cable connectors. The Power Cable Disconnected alarm will come on. This is normal.
5. Put aside the white Power Module patient cable connector.
6. Promptly connect the battery clip connector to the white System Controller power cable connector (**Figure 3.65**). The alarm will stop when the white System Controller power cable is connected.

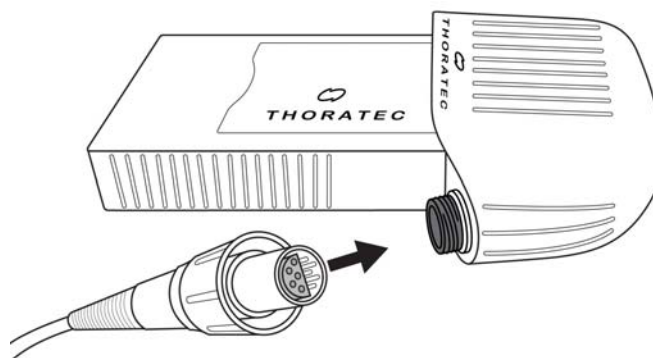

Figure 3.65 Connect the System Controller Power Cable Connector to the Battery Clip Connector

7. Unscrew the black System Controller connector and black Power Module patient cable connectors. The Power Cable Disconnected alarm will come on. This is normal.
8. Put aside the black Power Module patient cable connector.
9. Promptly connect the battery clip connector to the black System Controller power cable connector. The alarm will stop when the black System Controller power cable is connected.
10. Place the batteries and battery clips into the holsters or carrying case.
11. Keep the Power Module patient cable connected to or near the Power Module until next use.
12. Place at least two additional charged batteries in the travel case.

IMPORTANT! If the Power Module patient cable remains connected to the Power Module when not in use, ensure that the cable is located where it will not become damaged, dirty, or wet. The cable should be placed so that it will not cause tripping or falling.

Switching from the Mobile Power Unit to Battery-Powered Operation

Use care when connecting or disconnecting power cables. For more information, see *Guidelines for Power Cable Connectors* on page 7-45.

FOR THIS TASK YOU NEED:

- 1 running System Controller
- 1 working, in-use Mobile Power Unit with batteries installed
- 2 fully-charged HeartMate™ 14 Volt Lithium-Ion batteries
- 2 14 Volt battery clips
- Holster or carrying case

TO SWITCH FROM THE MOBILE POWER UNIT TO BATTERIES:

1. Place two battery clips, two charged batteries (as indicated by the green light on the Battery Charger), and the white and black Mobile Power Unit patient cable connectors within easy reach.
2. Place the first charged battery into a battery clip by lining up the arrows on the battery and battery clip and pushing until the battery clicks into place.
3. Repeat Step 2 for the second battery and battery clip.
4. Unscrew the white System Controller and white Mobile Power Unit patient cable connectors. The Power Cable Disconnected alarm will come on. This is normal.
5. Promptly connect the battery clip connector to the white System Controller power cable connector (**Figure 3.66**). The alarm will stop when the white System Controller power cable is connected, and tighten the nut.

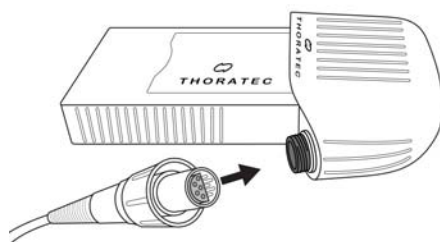

Figure 3.66 Connect the System Controller Power Cable Connector to the Battery Clip Connector

6. Unscrew the black System Controller and black Mobile Power Unit patient cable connectors. The Power Cable Disconnected alarm will come on. This is normal.
7. Promptly connect the battery clip connector to the black System Controller power cable connector. The alarm will stop when the black System Controller power cable is connected, and tighten the nut.
8. Place the batteries and battery clips into the holsters or carrying case.
9. Place at least two additional charged batteries in the travel case.

IMPORTANT! When not in use, place the Mobile Power Unit where it will not become damaged, dirty, or wet. The cable should be placed so that it will not cause tripping or falling.

Switching from Battery Power to the Power Module

Use care when connecting or disconnecting power cables. For more information, see *Guidelines for Power Cable Connectors* on page 7-45.

FOR THIS TASK YOU NEED:

- 1 running System Controller on 14 Volt Lithium-Ion battery power
- 1 functioning Power Module
- Functioning and grounded (3-prong) AC electrical outlet that is dedicated to Power Module use and not controlled by a wall switch
- 1 AC power cord to connect to an AC electrical power outlet
- 1 battery holster or other wear and carry accessory

TO SWITCH FROM BATTERIES TO THE POWER MODULE:

1. Confirm that the Power Module is plugged into a functioning and grounded (3-prong) AC electrical outlet that is dedicated to Power Module use.

WARNING !

- Do not use an outlet that is controlled by a wall switch.
- Do not use an adapter plug for an ungrounded wall outlet.
- Do not use portable, multiple outlet (power strip) adapters.
- Using adapters or power strips may cause a serious electrical shock or cause the Pump to stop.

2. Perform a Power Module self test (see *Performing a Power Module Self Test* on page 3-22).
3. If the Power Module fails the test, please contact Abbott; otherwise, continue with Step 4.

4. If the Patient Cable is connected to the Power Module, continue to Step 6. To connect the Patient Cable to the Power Module, line up the red dot on the patient cable with the red dot near the "♥" socket on the Power Module, and then insert the Power Module patient cable into the socket (**Figure 3.67**). The cable clicks into place when fully engaged in the socket.



Figure 3.67 Align the Red Dots

5. Tug gently on the black strain relief portion of the connector to confirm that the connection is tight. See **Figure 3.68**.

CAUTION !

Do not pull on the cable.



Figure 3.68 Tug on the Black Strain Relief Portion to Check the Connection

6. Place the black and white Power Module patient cable connectors and System Controller power cable connectors within reach.
7. Remove the battery clips and attached batteries from the patient's holsters or carrying case.
8. Check the charge status of each battery—press the battery power gauge on each battery to determine which battery has the least power (see *Checking Battery Charge Status Using the On-Battery Power Gauge* on page 3-56).

9. If one battery has less charge, start with that battery and disconnect the connector from the battery; otherwise, disconnect the white connector first.
10. Unscrew the white connector from its battery clip. The Power Cable Disconnected alarm will come on. This is normal.
11. Put aside the battery clip and attached battery.
12. Connect the white Power Module power patient cable connector to the white System Controller power cable connector. The alarm will stop.
13. Unscrew the black connector from its battery clip. The Power Cable Disconnected alarm will come on. This is normal.
14. Put aside the battery clip and attached battery.
15. Connect the black Power Module patient cable connector to the black System Controller power cable connector. The alarm will stop.
16. Press the battery release button on one of the battery clips to release its battery.
17. Repeat Step 16 for the second battery.
18. The System Controller is now connected to the Power Module, and the Power Module is powering the system. Store the battery clips in a clean, dry location until next use.
19. Place the depleted batteries into the Battery Charger for charging (see *Charging HeartMate Batteries* on page 3-80).

Switching from Battery Power to the Mobile Power Unit

Use care when connecting or disconnecting power cables. For more information, see *Guidelines for Power Cable Connectors* on page 7-45.

FOR THIS TASK YOU NEED:

- 1 running System Controller on 14 Volt Lithium-Ion battery power
- 1 functioning Mobile Power Unit
- Functioning AC electrical outlet that is dedicated to Mobile Power Unit use and not controlled by a wall switch
- 1 AC power cord to connect to an AC electrical power outlet
- 1 Battery Holster or other wear and carry accessory

TO SWITCH FROM BATTERIES TO THE MOBILE POWER UNIT:

1. Confirm that the Mobile Power Unit is plugged into a functioning AC electrical outlet that is dedicated to Mobile Power Unit use.

WARNING !

- Do not use an outlet that is controlled by a wall switch.
- Do not use portable, multiple outlet (power strip) adapters.

2. Place the black and white Mobile Power Unit patient cable connectors and System Controller power cable connectors within reach.
3. Remove the battery clips and attached batteries from the patient's holsters or carrying case.
4. Check the charge status of each battery—press the battery power gauge on each battery to determine which battery has the least power (see *Checking Battery Charge Status Using the On-Battery Power Gauge* on page 3-56).
5. If one battery has less charge, start with that battery and disconnect the connector from the battery; otherwise, disconnect the white connector first.
6. Unscrew the white connector from its battery clip and disconnect the cable. The Power Cable Disconnected alarm will come on. This is normal.
7. Put aside the battery clip and attached battery.
8. Connect the white Mobile Power Unit patient cable connector to the white System Controller power cable connector. The alarm will stop. Tighten the nut.
9. Unscrew the black connector from its battery clip and disconnect the cable. The Power Cable Disconnected alarm will come on. This is normal.
10. Put aside the battery clip and attached battery.
11. Connect the black Mobile Power Unit patient cable connector to the black System Controller power cable connector, and tighten the nut. The alarm will stop.
12. Press the battery release button on one of the battery clips to release its battery.
13. Repeat Step 12 for the second battery.
14. The System Controller is now connected to the Mobile Power Unit, and the Mobile Power Unit is powering the system. Store the battery clips in a clean, dry location until the next use.
15. Place the depleted batteries into the Battery Charger for charging (see *Charging HeartMate Batteries* on page 3-80).

Battery Charger Overview

The Battery Charger (**Figure 3.69**) is designed to charge the HeartMate 14 Volt Lithium-Ion batteries that are used to power the HeartMate 3 Left Ventricular Assist System during battery-powered operation. Specifically, the Battery Charger can:

- Charge up to four batteries in four hours or less (see *Charging HeartMate Batteries* on page 3-80).
- Monitor the need for calibration, and calibrate individual batteries (see *Calibrating HeartMate Batteries* on page 3-84).
- Perform diagnostic testing on up to four batteries at a time (see *Using the Charger to Check Battery Power* on page 3-86).



Figure 3.69 Battery Charger

WARNING !

- Do not use the Battery Charger next to other equipment. Do not stack the Battery Charger on top of other equipment.
- The Battery Charger radiates radio frequency energy. If the Battery Charger is not used according to instructions, it may cause harmful interference with nearby devices. To confirm if interference is occurring, turn off/on the Battery Charger and observe the effect on devices in the area. If interference is detected:
 - Re-orient or move the affected devices.
 - Increase the distance between the Battery Charger and the affected devices.
 - Connect the affected devices to an electrical outlet different from the outlet used to power the Battery Charger.
- To avoid the risk of electrical shock, plug the Battery Charger into a properly tested and grounded (3-prong) AC electrical power outlet that is dedicated to Battery Charger use.
 - Do not use an outlet that is controlled by a wall switch.
 - Do not use an adapter plug for an ungrounded wall outlet.
 - Do not use portable, multiple outlet (power strip) adapters.
- Keep the Battery Charger dry and away from water or liquid. If the Battery Charger comes in contact with water or liquid, it may fail to operate properly or you may get a serious electric shock.
- Do not use the Battery Charger in the presence of a flammable anesthetic mixture with air or with oxygen or nitrous oxide, or an explosion could occur.
- Be sure to use only equipment and supplies that are authorized by Abbott. If you use unauthorized parts, potential interference may occur between the Battery Charger and other devices.
- If traveling by aircraft, the patient should be instructed to bring sufficient battery power to power the system until the destination is reached. Neither the Mobile Power Unit nor the Battery Charger should be used on aircraft.

CAUTION !

- Use only the Battery Charger supplied by Abbott to charge HeartMate 14 Volt Lithium-Ion batteries. Other battery chargers may damage HeartMate batteries.
- Do not attempt to test or charge non-HeartMate batteries in the Battery Charger. Doing so may damage the charger or the batteries, or injure the user.
- Before inserting a battery into the Battery Charger for charging or recharging, inspect the battery for signs of damage. Do not use a battery that appears damaged.
- The Battery Charger requires planned maintenance at least once every 12 months for the best possible operation. Planned maintenance includes (but is not limited to) a functional check of the device and cleaning/inspecting all internal connections. Service and maintenance of the Battery Charger should be performed only by service personnel who are trained by Abbott.
- Make sure the Battery Charger is plugged in and turned on ("I") before placing batteries into the pockets for charging.
- Calibrate a battery as soon as possible after being prompted, to prevent a backlog of uncalibrated batteries. After approximately 70 uses, HeartMate batteries may need to be recalibrated. The Battery Charger indicates when a battery needs to be calibrated. Calibration can take up to 12 hours, and only one battery can be calibrated at a time.
- Leave a calibrating battery in the Battery Charger for the full calibration cycle. Removing a battery before it is fully calibrated may result in a depleted battery. The on-battery power gauge will reflect this status.
- Do not touch the metal contacts inside the Battery Charger when the charger is connected to AC power and turned on, or it may cause a serious electrical shock.
- Keep the metal contacts inside the Battery Charger pockets clean and dry. Dirty metal contacts inside the Battery Charger pockets may prevent proper battery charging, which can affect battery operation.

Setting Up the Battery Charger Before Use

Before using the Battery Charger to charge HeartMate batteries, it must be plugged in and turned on. The display panel on the front of the charger displays messages during setup and operation. See *Selecting Language Display Mode* on page 3-78, for instructions on selecting the language/display mode that best meets your needs.

FOR THIS TASK YOU NEED:

- 1 Battery Charger
- 1 grey AC power cord to connect to an AC electrical power outlet
- Functioning and grounded (3-prong) AC electrical outlet that is not controlled by a wall switch

TO SET UP THE BATTERY CHARGER:

1. If not already unpacked, carefully remove the charger from its packaging. Place the Battery Charger on a flat, sturdy surface.
2. Inspect the Battery Charger for dents, chips, cracks, or other signs of damage. Do not use a Battery Charger that seems damaged. Contact Abbott for a replacement, if needed.
3. Examine the four battery charging pockets. Make sure the pockets are clean and empty (no batteries), and free of dust or debris.
4. Pay particular attention to the metal contacts inside the pockets. Dirt or objects covering the metal contacts inside the pockets may prevent proper battery charging, which can affect battery performance.
5. Obtain the grey AC power cord from the product packaging.
6. Plug the female end of the power cord into the power entry module on the rear of the charger (**Figure 3.70**).



Figure 3.70 Plug the Power Cord Into the Battery Charger

7. Plug the Battery Charger into a properly tested and grounded (3-prong) AC electrical outlet that is dedicated to Battery Charger use. Do not use an outlet that is controlled by a wall switch. Do not use an adapter plug for an ungrounded wall outlet. Do not use portable, multiple outlet (power strip) adapters.

WARNING !

- For international travel, the patient needs a Abbott power cord. The power cord must be compatible with the local voltage, and meet applicable national plug, rated voltage, rated current, and safety agency marks and specifications. Contact Abbott for a power cord, if needed. Refer to the *Back Cover* of this manual for Abbott contact information.
- If traveling by aircraft, instruct the patient to bring sufficient battery power to power the system until the destination is reached. Neither the Mobile Power Unit nor the Battery Charger should be used on aircraft.

8. Turn on the Battery Charger by pressing the on/off switch on the rear of the charger from the off ("0") to the on ("I") position. When the Battery Charger is turned on, all lights on the front panel turn on (**Figure 3.71**). The charger beeps once and performs a self test. The self test takes about 10 seconds.



Figure 3.71 Display Panel During Battery Charger Self Test

9. After a successful self test, all lights turn off and "HeartMate CHARGER" appears on the display panel (**Figure 3.72**). The charger is ready for use.



Figure 3.72 "HeartMate CHARGER" Screen on the Battery Charger

10. If the charger detects a problem, an error message appears on the display panel and/or the lights and beep are not performed as described above. If an error message appears, or the lights or beep are missing or do not perform as described, see *Using the Charger to Check Battery or Charger Status* on page 7-42 for how to respond to advisory messages (**Figure 3.73**).



Figure 3.73 Sample Error Message

Note: Any time the "HeartMate CHARGER" message is displayed, the display panel slowly dims, turns off for two seconds, and then resumes full brightness. This helps to prolong the life of the display. You may use the charger during this time.

Selecting Language Display Mode

The display panel screen has two language display modes:

- Graphic Symbols
- English Text

Selecting the Language Display Mode Before Using the Charger for the First Time

Graphic Symbols is the default display mode. You can change the language display mode from Graphic Symbols to English Text.

FOR THIS TASK YOU NEED:

- 1 Battery Charger
- 1 grey AC power cord to connect to an AC electrical power outlet
- Functioning and grounded (3-prong) AC electrical outlet that is not controlled by a wall switch

TO SELECT THE LANGUAGE DISPLAY MODE BEFORE USING THE BATTERY CHARGER:

1. Unpack and plug in the Battery Charger; however, do not turn on the charger at this time.
2. Press and hold buttons 1 and 3 on the front panel of the charger (**Figure 3.74**), and at the same time, press the power switch to the "on" position.



Figure 3.74 Press and Hold Buttons 1 and 3 to Change the Display Mode

3. After "English" appears on the display (**Figure 3.75**), release buttons 1 and 3.



Figure 3.75 English Text Display

4. To set English Text as the desired display mode, press and release the 1 button.

OR

5. To set Graphic Symbols as the desired display mode, press and release the 2 button, scroll down to Graphic, and then press and release button 1.

IMPORTANT! After releasing the 1 button, the charger conducts a self test. If the test is successful, "HeartMate CHARGER" appears on the screen.

Selecting the Language Display Mode After Startup

FOR THIS TASK YOU NEED:

- 1 Battery Charger
- 1 grey AC power cord to connect to an AC electrical power outlet
- Functioning and grounded (3-prong) AC electrical outlet that is not controlled by a wall switch

TO SELECT THE LANGUAGE DISPLAY MODE AFTER STARTUP:

1. Remove all batteries from the charging pockets.
2. Turn off the charger by pressing the on/off switch from the on ("I") to the off ("O") position.
3. Do not unplug the Battery Charger.
4. Press and hold buttons 1 and 3 on the front panel of the charger, and press the power switch to the on ("I") position.
5. After the display panel lights up, release buttons 1 and 3. The charger powers up.
6. Use the 2 button to scroll down to the desired display mode.
7. When the desired display mode appears, press and release the 1 button.

IMPORTANT! The charger conducts a self test. If the test is successful, "HeartMate CHARGER" appears on the screen.

Charging HeartMate Batteries

The Battery Charger can charge up to four 14 Volt Lithium-Ion batteries at the same time. It takes up to four hours to charge from one to four batteries, depending on the charge status of the batteries. Be sure to plan battery use and charging, taking into account four hours for charging.

For best battery performance, leave charged batteries in the charging pockets until ready for use. Leaving charged batteries in the Battery Charger will not damage them.

HeartMate 14 Volt Lithium-Ion batteries use technology that measures available battery power and counts battery usage/charge cycles. When a battery is placed in a charging pocket (**Figure 3.76**), the charger immediately checks the battery's status by reading the battery's on-board computer chip.



Figure 3.76 Batteries Inserted into Battery Charger Pockets

To view information about the battery's available power and total number of use/charge cycles on the charger's display panel, press the number button for that pocket (see *Using the Charger to Check Battery Power* on page 3-86). Depending on the status of the battery, one of three lights (green, yellow, or red) located next to the pocket is illuminated (**Figure 3.77**).



Figure 3.77 Charge Status Lights (Green, Yellow, Red) for Pockets 1 through 4

A green light means the battery is charged and ready for use. A steady yellow light means the battery is actively charging. A red light means the battery is defective or the charger has a problem. See **Table 3.3** for a complete description of charger pocket light color codes.





Color	Status/Meaning
Green 	Battery is charged and ready for use.
Yellow 	Battery is undergoing charge, test, or calibration.
Yellow (Blinking) 	Battery requires calibration cycle.
Red 	Battery or charging pocket is defective. Do not use battery.

Table 3.3 Color Codes for Charger Pocket Lights

FOR THIS TASK YOU NEED:

- 1 functioning Battery Charger
- 1 grey AC power cord to connect to an AC electrical outlet
- Functioning and grounded (3-prong) AC electrical outlet that is not controlled by a wall switch
- Up to 4 HeartMate 14 Volt Lithium-Ion batteries

TO CHARGE 14 VOLT LITHIUM-ION BATTERIES:

1. Place a battery into one of the four battery charging pockets, so the battery power gauge is at the top and facing forward (**Figure 3.78**).



Figure 3.78 Battery Charger with Batteries Inserted in All Pockets

IMPORTANT! Do not force a battery into a charging pocket. A battery only fits in the pocket with the battery power gauge at the top and facing forward. When the battery is properly placed in the pocket, a beep sounds and one of the pocket lights is illuminated (green, yellow, or red).

2. Identify which light (green, yellow, or red) comes on for the pocket:
 - Green light—The battery is charged and ready for use. Either remove the battery for immediate use, or leave the battery in the pocket until needed. Leaving a charged battery in the charger will not damage it.
 - Yellow light—The battery is actively charging. Leave the battery in the pocket to continue charging. The yellow light remains on until the battery becomes charged. When the battery is charged, the yellow light turns off and the green light comes on.
 - Blinking yellow light—See *Calibrating HeartMate Batteries* on page 3-84.

- Red light or no light at all—The battery or charger pocket has a problem. Remove the battery and reinsert it in the same pocket. If the same condition occurs (red light or no light), insert the battery into a different pocket. If the battery cannot be charged in a different pocket, the battery is defective. Do not use the defective battery. Contact Abbott for a replacement, if needed. See *Using the Charger to Check Battery or Charger Status* on page 7-42 for information on advisory messages and troubleshooting, including how to read alarm codes when a red light comes on.
3. After approximately four hours, check the lights for the charging pocket for the battery.
 - If the green light is on, the battery is charged and ready for use.
 - If the yellow light is on, the battery is still charging.
 - If the red light is on, the battery has a problem or the charger interrupted the charging cycle for some reason. See *Using the Charger to Check Battery or Charger Status* on page 7-42 for how to handle red light conditions.
 4. Repeat Steps 1–3 for up to three more batteries.

CAUTION !

Avoid covering or blocking the vents on the top of the Battery Charger during use. Covering or blocking the vents may affect performance.

Calibrating HeartMate Batteries

HeartMate 14 Volt Lithium-Ion batteries use technology that measures available battery power and counts battery usage/charge cycles. After approximately 70 battery uses, the battery senses that it needs to calibrate its battery power gauge. Calibration helps keep the battery power gauge accurate.

During calibration, the charger drains the battery of all electrical energy and then recharges it. The battery must be placed in the charger to be calibrated. Battery calibration can take up to 12 hours, and only one battery can be calibrated at a time. While calibrating one battery, the charger can charge three HeartMate batteries as usual.

When a battery is inserted in the charger, and the charger detects that calibration is recommended:

- The yellow light for the pocket blinks.
- A split battery symbol and the pocket number for the battery flashes on the charger display panel (**Figure 3.79**). The circled number switches between a filled and unfilled circle as the display panel screen flashes.



Figure 3.79 Calibration Prompt (in Graphic Mode) Indicates that the Battery in Pocket 4 Needs Calibration

You can calibrate a battery when prompted, or wait for a more convenient time, such as at night or when the patient is sleeping and using the Power Module or Mobile Power Unit for power.

FOR THIS TASK YOU NEED:

- 1 functioning Battery Charger
- 1 grey AC power cord to connect to an AC electrical outlet
- Functioning and grounded (3-prong) AC electrical outlet that is not controlled by a wall switch
- 1 HeartMate 14 Volt Lithium-Ion battery ready that needs to be calibrated

TO CALIBRATE THE BATTERY WHEN PROMPTED:

- Within ten seconds of the start of the blinking yellow light, press and release the number button for this pocket. The charger begins calibrating the battery.

IMPORTANT! During calibration, the yellow light for this pocket remains on and *HeartMate CHARGER* appears on the display panel screen. If the number button is pressed for this pocket while the battery is being calibrated, the calibration status screen appears (**Figure 3.80**). When calibration is complete, the yellow light turns off and the green light comes on. This indicates that the battery is charged and ready for use.



Figure 3.80 Calibration Status Screen Indicating that Battery in Pocket 4 is Being Calibrated

TO CHARGE THE BATTERY NOW (AND CALIBRATE THE BATTERY AT A FUTURE TIME):

- Do nothing when the yellow light begins blinking. After ten seconds, the charger continues with a normal charge cycle.

IMPORTANT! It is acceptable to charge and reuse the battery, but you should calibrate it as soon as possible.

If you choose to calibrate the battery, and then decide to cancel the calibration after the process has begun, you can cancel calibration by removing the battery from its pocket. If you do remove a battery before calibration is complete, be sure to recharge and check the battery before using it. If you remove a battery before calibration ends, the battery may be depleted (use the on-battery power gauge to check the battery charge status).

CAUTION !

Calibrate a battery as soon as possible after being prompted to do so to ensure the best possible battery performance. Calibration can take up to 12 hours. Therefore, be sure to have enough charged batteries available before calibration begins. Under normal conditions, have four charged batteries available so that batteries can be exchanged twice during a 12-hour calibration cycle.

Using the Charger to Check Battery Power

You can use the Battery Charger to check the status of a battery. To check a battery's charge status, place the battery into a charging pocket, and then press and release the number button for that pocket. The following information appears on the charger display panel (**Figure 3.81**):

- Pocket number
- Battery symbol
- Percentage of available charge

For example, if approximately 50% of the battery's power is available, half of the battery symbol is filled and "50%" appears on the screen.

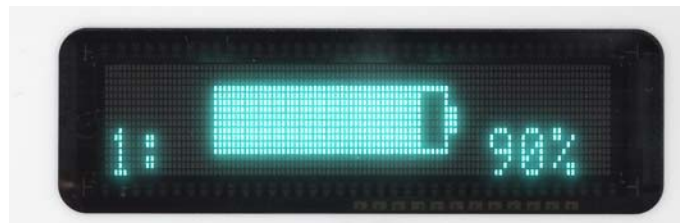

Figure 3.81 View Battery Charge Level on Battery Charger (this example shows 90% charge)

After five seconds, the display returns to the default screen ("HeartMate CHARGER"). If you press the button again—while the battery charge level appears—the display shows the total number of use/charge cycles. The following information appears on the display panel:

- Pocket number
- Total number or uses/charges for this battery
- How much power the battery can potentially hold if fully charged (measured in mAh)

After 10 seconds, the display panel returns to the default ("HeartMate CHARGER") screen.

Care and Maintenance of the Battery Charger

The Battery Charger requires periodic inspection and cleaning for the best possible performance. For detailed information on inspecting and cleaning the Battery Charger, see *Safety Checklists* on page F-1.

CAUTION !

Service and maintenance of the Battery Charger should be performed only by service personnel who are trained by Abbott.

IMPORTANT! The hospital contact is responsible for coordinating annual inspection and maintenance of the Battery Charger after the patient leaves the hospital.

Disposing of the Battery Charger

See *Product Disposal* on page 8-11 for information about disposing of the Battery Charger.

HEARTMATE TOUCH™ COMMUNICATION SYSTEM

This section describes how to use the HeartMate Touch™ Communication System to program and monitor the HeartMate 3™ Left Ventricular Assist System.

Overview - - - - -	4-2
Set Up the HeartMate Touch™ Communication System - - - - -	4-7
Connect the HeartMate Touch™ Wireless Adapter to the HeartMate Touch Communication System - - - - -	4-11
Interface Overview - - - - -	4-20
HeartMate Touch™ App Views - - - - -	4-21
Settings Panel - - - - -	4-23
Alarms - - - - -	4-40
Pump Parameters - - - - -	4-50
Monitor View - - - - -	4-55
Clinical View - - - - -	4-56
Historical View - - - - -	4-62

Overview

The HeartMate Touch™ Communication System is intended for use by clinicians in the hospital to provide a detailed, large-scale display of system performance. The HeartMate Touch Communication System is required during implant procedures and any time close monitoring of system operation is needed. The Tablet should be placed on a stable surface. The HeartMate Touch Communication System is shown on top of the Power Module (**Figure 4.2**)

The Tablet for use with the HeartMate Touch App must be connected to the Power Module through a Bluetooth® pairing to the HeartMate Touch™ Wireless Adapter. In addition, the Power Module must be connected to the System Controller. These connections allow the transfer of System Controller data through the Power Module for display on the Tablet display screen. The wireless communication range with the HeartMate Touch Wireless Adapter is up to 5 meters (16.40 feet). The HeartMate Touch Communication System should only be used when in direct view of the patient.

The HeartMate Touch Communication System is used to:

- Closely monitor system operation during Left Ventricular Assist Device implant.
- Display information about system performance, including current operating mode (ie, "pulse"), pump flow, pump speed, and overall operational status.
- Program system parameters, such as pump speed.
- Assess and track alarm conditions.
- View and save performance data.
- Record data at specific intervals to download for review and analysis.



Figure 4.1 HeartMate Touch™ Communication System

IMPORTANT! For a getting started guide to using the HeartMate Touch Communication System see the HeartMate Touch Communication System Quick Start Guide.



Figure 4.2 HeartMate Touch™ Communication System on top of the Power Module

Required Components

HeartMate Touch™ App. The HeartMate Touch App provides clinicians with the ability to wirelessly monitor a patient's HeartMate system, program system parameters such as pump speed, assess and track alarm conditions, and view and save performance data. Its use during Left Ventricular Assist Device implantation is required.



Tablet for use with the HeartMate Touch App. The tablet deployed with HeartMate Touch App serves as the display screen and is installed in a protective case.



HeartMate Touch™ Wireless Adapter. The HeartMate Touch Wireless Adapter facilitates Bluetooth® pairing, when it is connected to the Power Module. The wireless communication range with the HeartMate Touch Wireless Adapter is up to 5 meters (16.40 feet). Every HeartMate Touch Wireless Adapter has its unique ID number, to ensure correct pairing.



Power Adapter and USB cable. The Power Adapter and 2-meter (6.56 feet) USB cable with Lightning‡ connector are used to charge the Tablet from a power outlet.



Flash Drive. The Flash Drive has a Lightning connector and USB connector. The Flash Drive is used for exporting, transferring, and storing data generated from the HeartMate Touch App.



WARNING !

- Do not disconnect the Power Module patient cable from the Power Module when troubleshooting for a "Connection lost to HeartMate 3 Controller" notification on the HeartMate Touch™ App.
- Do not disconnect the System Controller power cable connectors from the Power Module when troubleshooting a "Connection lost to HeartMate 3 Controller" notification on the HeartMate Touch App.
- The HeartMate Touch System may be interfered with by other equipment, even if that other equipment complies with CISPR EMISSION requirements.

CAUTION !

- To prevent system component damage and personal injury, refer any servicing of HeartMate Left Ventricular System equipment to Abbott-trained service personnel only.
- Use of equipment and supplies, other than those specified in this manual or sold by Abbott for replacement parts, may affect the electromagnetic compatibility of the Left Ventricular Assist System with other devices, resulting in potential interference between the Left Ventricular Assist System and other devices.
- If the Tablet for use with the HeartMate Touch App is mounted on top of the Power Module, do not attempt to lift or carry the two components. Doing so may damage the Power Module and/or Tablet for use with the HeartMate Touch App.
- Pump flow is estimated from pump power. Under abnormal conditions this may result in an overestimation of pump flow or an undisplayed pump flow reading (see *Pump Flow* on page 4- 51).
- No single parameter is a surrogate for monitoring the clinical status of the patient, and the changes in all parameters should be considered when assessing any clinical situation.
- Position the Power Module and HeartMate Touch Communication System away from sources of lint, dust, and pests, and away from heat and/or humidity sources such as a fireplace, radiant heater, nebulizer, or a steam kettle.
- Use the HeartMate Touch Communication System only when in the direct view of the patient.

The HeartMate Touch Wireless Adapter contains a radio transmitter/receiver with the following parameters.

Radio transmitter/receiver parameters:

- Frequency (range): 2.402 to 2.480 GHz
- Channels: 40 logical channels using Adaptive Frequency Hopping (AFH)
- Bandwidth: 2 MHz
- Modulation: Gaussian Frequency Shift Keying (GFSK)
- Effective Radiated Power (ERP): +5.53 dBm (3.45 mW) maximum

Set Up the HeartMate Touch™ Communication System

Set Up the HeartMate Touch™ Wireless Adapter

FOR THIS TASK YOU NEED:

- 1 running System Controller connected to the Power Module via a Power Module patient cable
- 1 Power Module with an installed backup battery. The Power Module must be connected to a functioning and grounded (3-prong) AC electrical outlet dedicated to Power Module use and is not controlled by a wall switch.
- 1 Tablet for use with the HeartMate Touch App
- 1 HeartMate Touch™ Wireless Adapter
- 1 Functioning and grounded (3-prong) AC electrical outlet
- 1 AC power cord

TO SET UP THE HEARTMATE TOUCH WIRELESS ADAPTER FOR USE WITH THE POWER MODULE:

1. Power on the Power Module. See *Using the Power Module* on page 3-4 for instructions.
2. Observe the front panel of the Power Module. The green "Power On" light should illuminate. If the light does not illuminate, the device may be defective. Do not use a defective device. Contact Abbott for a replacement, if needed. See **Figure 4.3**.

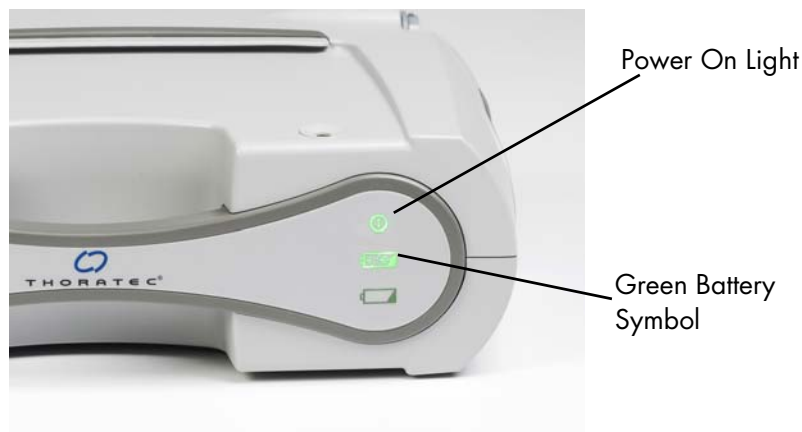

Figure 4.3 Power On and Battery Symbols are Green – Power Module is Ready for Use

WARNING !

- Confirm that the Power Module is plugged into a properly tested and grounded (3-prong) AC electrical outlet that is dedicated to Power Module use.
- Do not use an outlet that is controlled by a wall switch.
- Do not use an adapter plug for an ungrounded wall outlet.
- Do not use portable, multiple outlet (power strip) adapters.

3. Gently press inward on the Power Module retention clip to disengage the clip ends from the slots on the Power Module (**Figure 4.4**).



Figure 4.4 Disengage the Retention Clip

- Slide the loop of the HeartMate Touch Wireless Adapter tether onto the retention clip.



Figure 4.5 Loop Tether on Retention Clip

- With the tether still attached, lift the power cord retention clip into the locked position.
- Insert the two ends of the clip into the slots. Ensure the clips are securely engaged (**Figure 4.6**).



Figure 4.6 Insert Clip Ends into Slots

7. Insert the HeartMate Touch Wireless Adapter into the socket located on the side of the Power Module (Figure 4.7) above the Power Module power cord.



Figure 4.7 Insert the HeartMate Touch™ Wireless Adapter into the Power Module Socket

Note: The HeartMate Touch Wireless Adapter light displays a white light for 1 second upon connection (Figure 4.8).



Figure 4.8 HeartMate Touch Wireless Adapter Light Flashes White

Connect the HeartMate Touch™ Wireless Adapter to the HeartMate Touch Communication System

CAUTION !

The HeartMate Touch™ Communication System should be fully charged, or its power cable should be plugged in before starting this procedure.

1. To turn on the tablet, press and hold the top button until the logo appears.

IMPORTANT! Keep the Wi-Fi† and software automatic updates turned off in the Tablet for use with the HeartMate Touch App. Follow Abbott’s instructions regarding when to connect to Wi-Fi† and the process for maintaining approved software. Installing iOS‡ updates without Abbott notification may impact product use. If you have any questions, contact your local Abbott representative at any time.

Note: Before launching the HeartMate Touch App, setup the Tablet (in Settings) for the specific region, time zone, the language and time format that the Tablet is going to be used. Date and time display may vary and is dependent on your Settings and HeartMate Touch App language selected. Date and time displayed in the header (**Figure 4.9**) may also vary and is dependent on your Settings. Header format and content is subject to change.



Figure 4.9 Header

2. Tap  to launch the HeartMate Touch™ App.

3. Tap the **Language** drop-down to select a language that matches the language selected for the Tablet (in the Settings). A language change confirmation message appears.

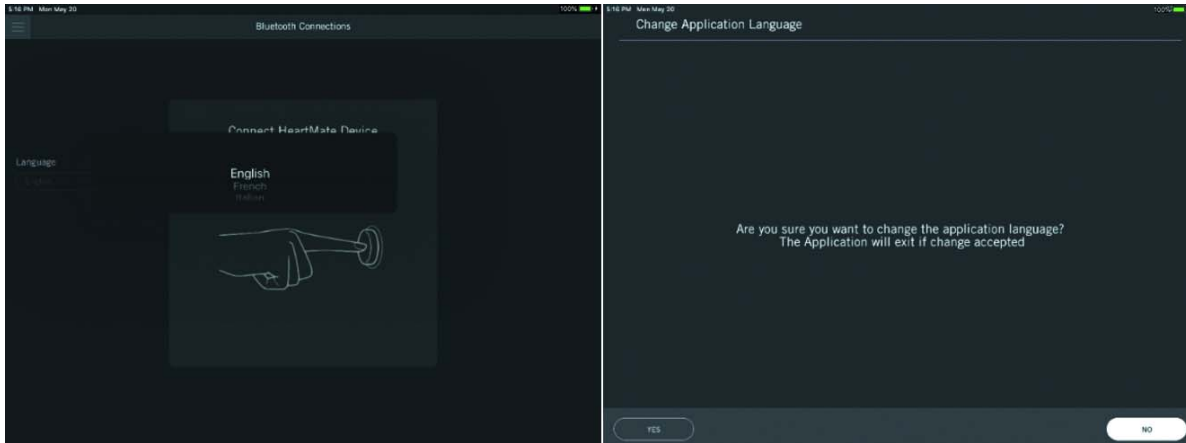



Figure 4.10 Select a Language / Confirm

4. Tap **YES**. The HeartMate Touch App closes.
5. Tap  to launch the HeartMate Touch App. Press and hold the button on the HeartMate Touch Wireless Adapter.

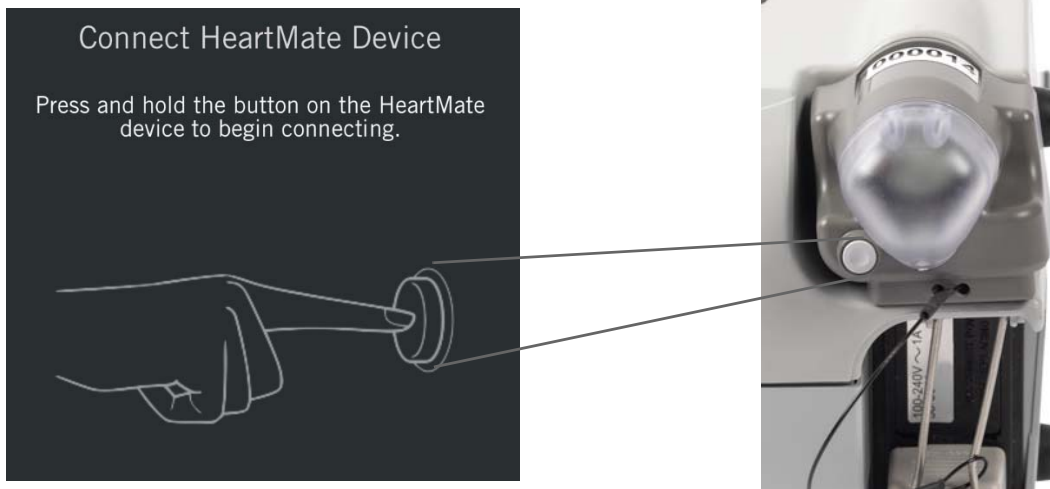

Figure 4.11 Press and hold the HeartMate Touch Wireless Adapter Button

A blinking blue light appears. See *HeartMate Touch™ Wireless Adapter Status* on page 4- 18 for more information regarding the HeartMate Touch™ Wireless Adapter status.

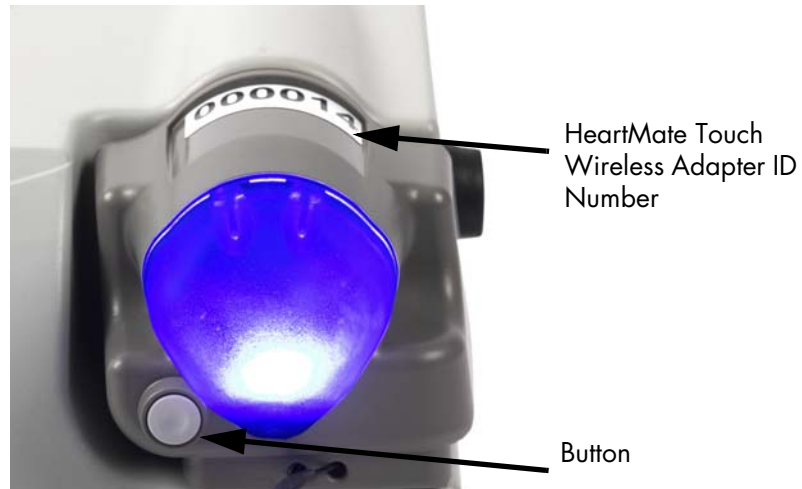

Figure 4.12 HeartMate Touch™ Wireless Adapter Button

The HeartMate Touch App displays the available HeartMate Touch Wireless Adapter(s) chronologically from top to bottom.

6. Read the HeartMate Touch Wireless Adapter ID and match it to the available HeartMate Touch Wireless Adapters displayed on the screen. Select the Adapter ID number and tap **Connect**.

CAUTION !

Select the Adapter ID number that matches the number on the HeartMate Touch Wireless Adapter label.

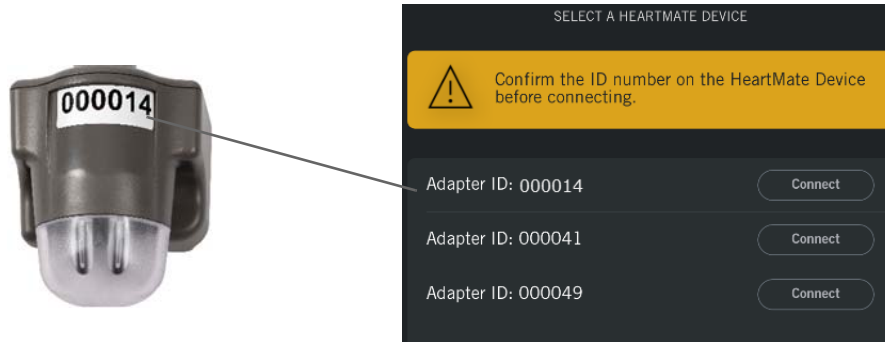

Figure 4.13 Select Adapter ID Number

Note: If the HeartMate Touch Wireless Adapter that you intend to connect to is not listed, check that the HeartMate Touch Wireless Adapter is ready to connect (e.g., displays a blinking blue light) and tap **Refresh** (🔄).

7. A Bluetooth® Connections window appears. Enter the HeartMate Touch Wireless Adapter code in the Bluetooth Pairing Request box.

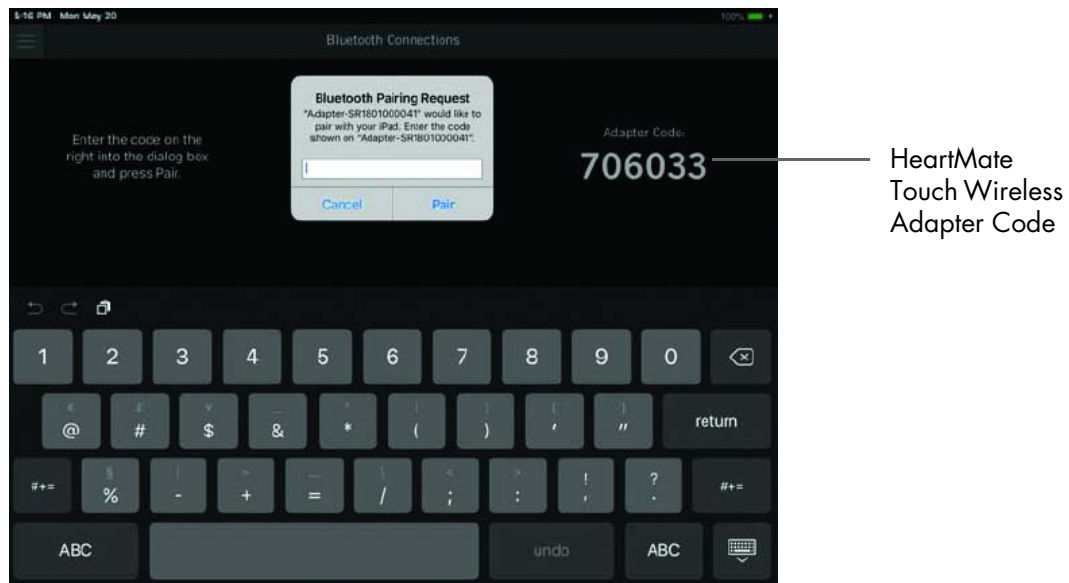

Figure 4.14 Enter HeartMate Touch Wireless Adapter Code

8. Tap **Pair**.

Note: The passcode is for first time pairing only.

Note: If the HeartMate Touch Wireless Adapter is not paired within 30 seconds, the connection process (pair) will be canceled.

9. Connect the System Controller to the Power Module and then wait for **CONTINUE** to become active (**Figure 4.15**).

Note: It may take a few seconds after the System Controller is connected for **CONTINUE** to become active.

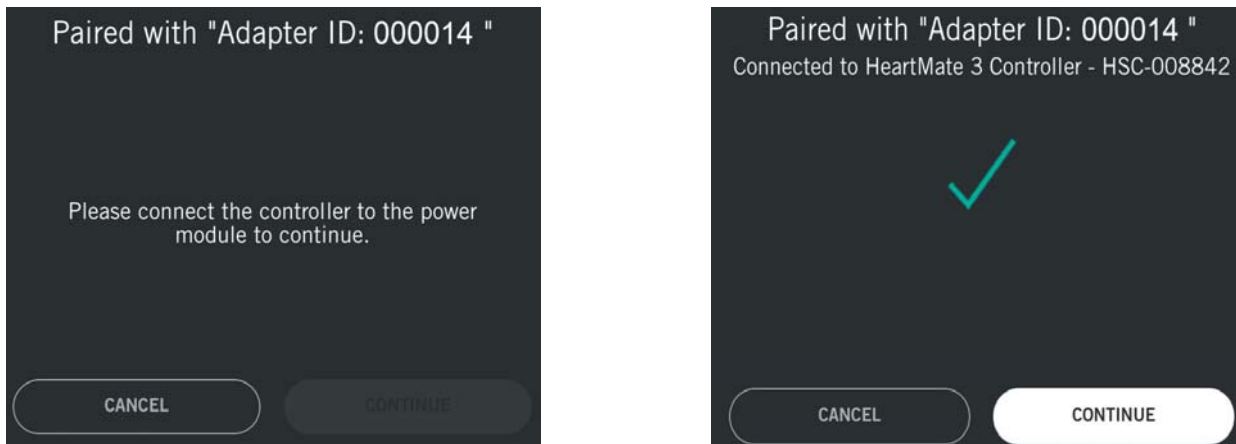

Figure 4.15 Confirm the ID Number and System Controller Serial Number

10. Confirm the Adapter ID number and System Controller serial number before moving on to the next step.
 - a. Confirm that the HeartMate Touch Wireless Adapter ID number displayed matches the number on the HeartMate Touch Wireless Adapter label and tap **CONTINUE**. If the displayed ID number does not match, tap **CANCEL** and restart the connection process.
 - b. Confirm that the System Controller model and serial number displayed matches the patient's System Controller serial number. If the displayed model / serial number does not match, tap **CANCEL** and restart the connection process.

WARNING !

Confirm that the HeartMate Touch Wireless Adapter ID number displayed matches the number on the HeartMate Touch Wireless Adapter label. If the displayed HeartMate Touch Wireless Adapter ID number does not match, you are not connected to the correct HeartMate device. Tap **CANCEL** and restart the connection process.

11. Create a name for this session and tap **Done**.

IMPORTANT! Only create names that identify the session. Do not enter any protected health information or individually identifiable health information. Follow your organization's policies, procedures, and employee training that correspond to HIPAA regulatory standards.

IMPORTANT! You should restrict the characters to a through z, 0 through 9, underscores (_), and periods (.).

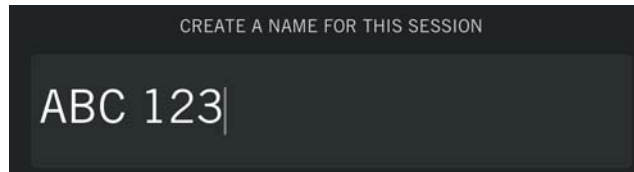

Figure 4.16 Create a Session Name

12. The HeartMate Touch App displays the Monitor view. The HeartMate System Controller information and session name appear at the top of the view.

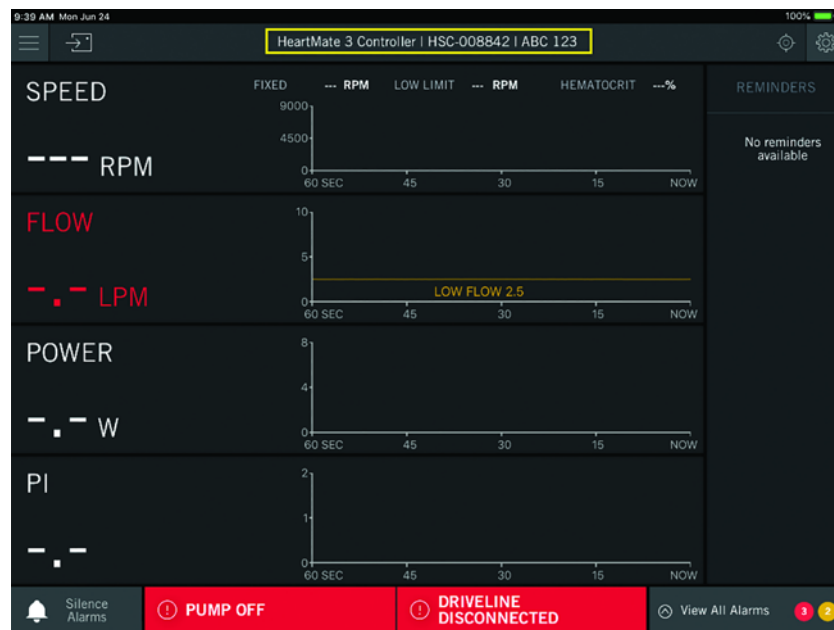

Figure 4.17 Monitor View

Disconnect

There may be instances when you need to disconnect the HeartMate Touch App from the HeartMate Touch Wireless Adapter. (e.g., You need to replace the HeartMate Touch Wireless Adapter.)

1. Tap **Menu** (☰).

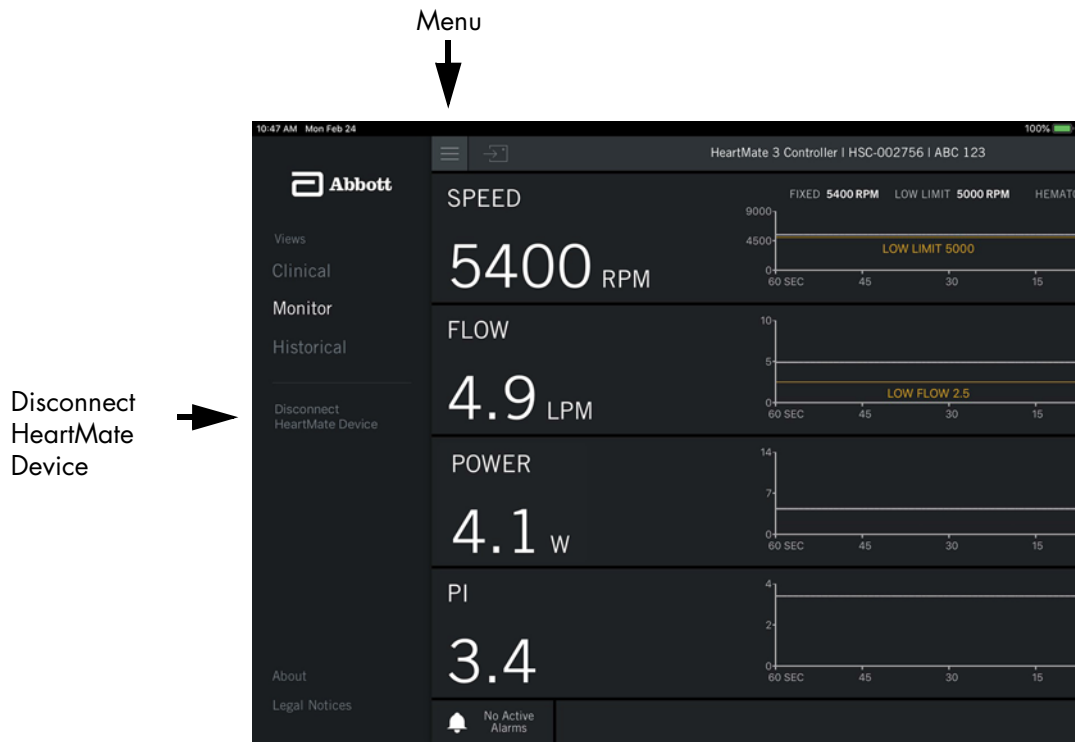

Figure 4.18 Disconnect HeartMate Device

2. Tap **Disconnect HeartMate Device**. A confirmation message appears asking you to confirm.
3. Tap **YES** to disconnect the HeartMate Touch™ App from the HeartMate Touch Wireless Adapter.

TO DISCONNECT THE HEARTMATE TOUCH WIRELESS ADAPTER FROM THE POWER MODULE:

1. Gently press inward on the Power Module retention clip until one side of the clip is disengaged.
2. Slide the loop of the HeartMate Touch Wireless Adapter tether off the retention clip.
3. Lock the retention clip into its original position.
4. Remove the HeartMate Touch Wireless Adapter from the socket located on the side of the Power Module.

HeartMate Touch™ Wireless Adapter Status

When the HeartMate Touch™ Wireless Adapter is connected to the Power Module the HeartMate Touch Wireless Adapter light will illuminate to indicate its operating status. The HeartMate Touch Wireless Adapter status conditions are shown below.

Powered On. The HeartMate Touch Wireless Adapter will illuminate a white light for 1 second upon connection to the Power Module.



Figure 4.19 Solid White Light for 1 Second

Standby Mode. The HeartMate Touch Wireless Adapter is in standby mode and is not yet wirelessly connected to the HeartMate Touch™ App.



Figure 4.20 Light is Off

Ready to Connect. After pressing and holding the round button, the HeartMate Touch Wireless Adapter will illuminate a blinking blue light. This light indicates the HeartMate Touch Wireless Adapter is ready to accept a wireless connection to a HeartMate Touch App for up to 60 seconds. If the HeartMate Touch Wireless Adapter is not responding, change to a new HeartMate Touch Wireless Adapter.

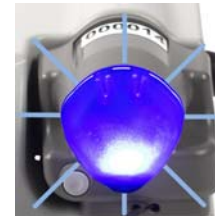

Figure 4.21 Blinking Blue Light

Connected. The HeartMate Touch Wireless Adapter will illuminate a solid blue light when it is connected to and communicating with the HeartMate Touch App.



Figure 4.22 Solid Blue Light

Locate. The HeartMate Touch Wireless Adapter will illuminate a blinking blue and white light when the HeartMate Touch App is locating and identifying the HeartMate Touch Wireless Adapter. The light will blink for up to 10 seconds.

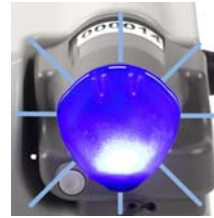



Figure 4.23 Blinking Blue and White Light

Interface Overview

The regions discussed on this page are displayed in all views (Clinical, Monitor, Historical).





Figure 4.24 Global Navigation

1 Menu. Tap **Menu** () . You can then choose from these views: Clinical, Monitor, Historical. You can also disconnect the HeartMate Device.

2 Communication Icon. The flashing communication icon () indicates active communication between the System Controller and HeartMate Touch™ App. If the icon is not flashing or has disappeared, restart the connection. Refer to *Connect the HeartMate Touch™ Wireless Adapter to the HeartMate Touch Communication System* on page 4-11.

3 Connected Device Information. Displays the System Controller serial number and the current session name.

4 Locate. Tap **Locate** () and the HeartMate Touch™ Wireless Adapter to which you are connected will blink blue and white. This feature helps identify the device to which you are connected.

5 Settings. Tap **Settings** () to access the Pump, Controller, and Backup Battery settings and information.

6 Alarm Silence. Displays the alarm silence status. You can also silence active alarms by tapping  **Silence Alarms**.

7 Alarm Status. Displays the top two active alarms.

8 View All Alarms. Tap **View All Alarms** to view a full list of active and inactive alarms.

HeartMate Touch™ App Views

The HeartMate Touch™ Communication System touchscreen interface contains 3 views: Clinical, Monitor, Historical.

To select a view, tap **Menu** (☰) > **Clinical**, **Monitor**, or **Historical**.

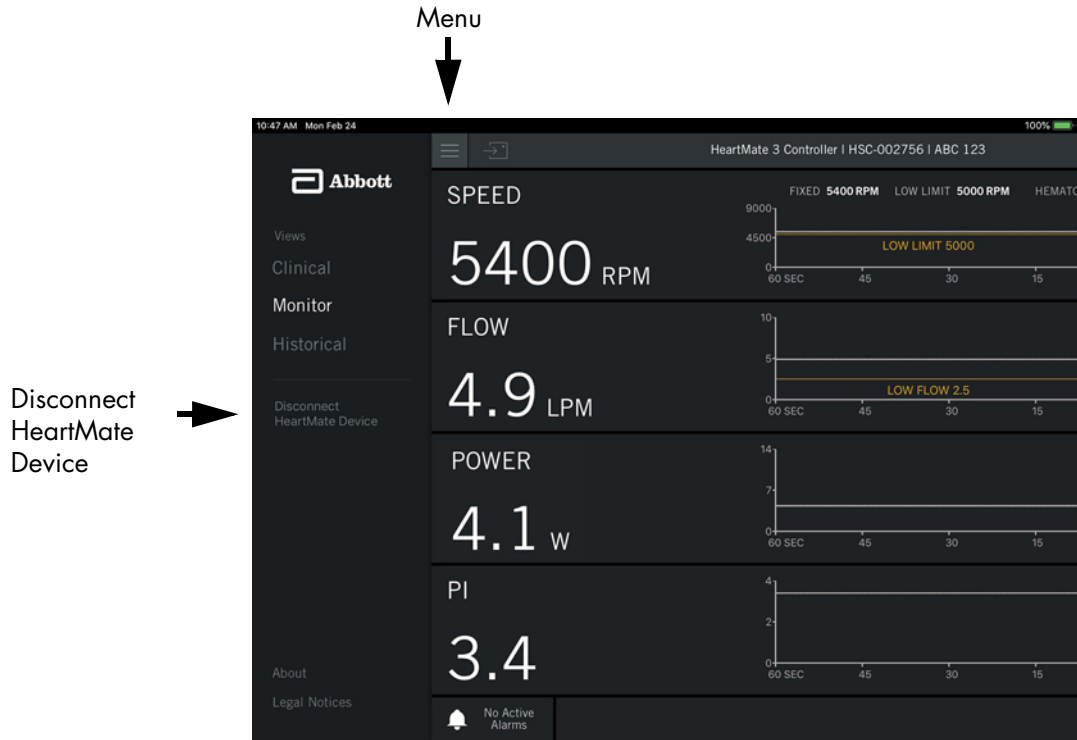

Figure 4.25 Menu > Clinical, Monitor, or Historical

Monitor View. The Monitor view is the default screen displayed upon connection. It displays primary operating parameters (Speed, Flow, Power, and PI) with trendlines. The Monitor view also has a reminders panel (right). The Reminders Panel provides reminders such as when to replace the System Controller Backup Battery.



Clinical View. The Clinical view is intended to be used during the implant procedure. It is the only view with the ability to start, prime, and stop the pump. It displays the primary operating parameters (Speed, Flow, Power, PI) with trendline information for pump, speed, and flow.



Historical View. The Historical view displays the event and periodic records that are stored in the System Controller and LVAD. Primary operating parameters (Speed, Flow, Power, and PI) are shown at the top of the screen without trendlines.

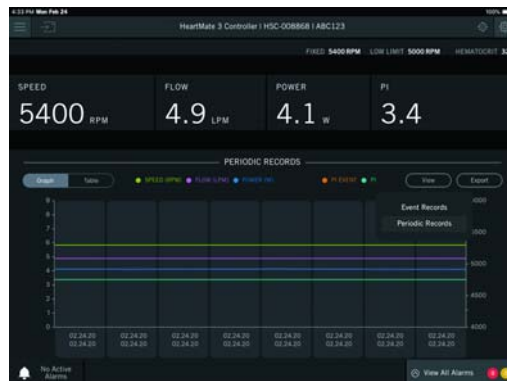

Settings Panel

Tap **Settings** (⚙️) to access the settings panel. The settings panel has three tabs: 1. Pump, 2. Controller, 3. Backup Battery.

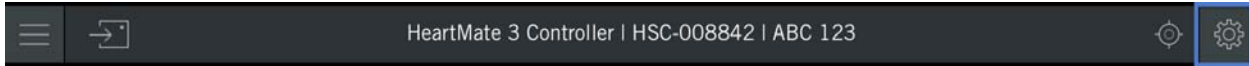

Pump Tab

The Pump tab lets you view and set the pump settings, and view detailed LVAD information.

CAUTION !

Verify that the HeartMate Touch™ Communication System is connected to the intended HeartMate LVAS when making changes to LVAS settings.

Fixed Speed. Sets the fixed speed for the pump. For more information, refer to *Fixed Speed* on page 4-24.

Low Speed Limit. Sets the low speed limit for the pump. For more information, refer to *Low Speed Limit* on page 4-27.

Hematocrit. Sets the hematocrit % to improve the accuracy of the flow estimation from the pump. Refer to *Hematocrit* on page 4-29 for more information.

Graph Trendline Duration. Sets trendline duration for pump parameter settings. See *Graph Trendline Duration* on page 4-31 for more information.

LVAD Information. The LVAD Information region provides LVAD specifics such as pump mode, serial number, and software versions.

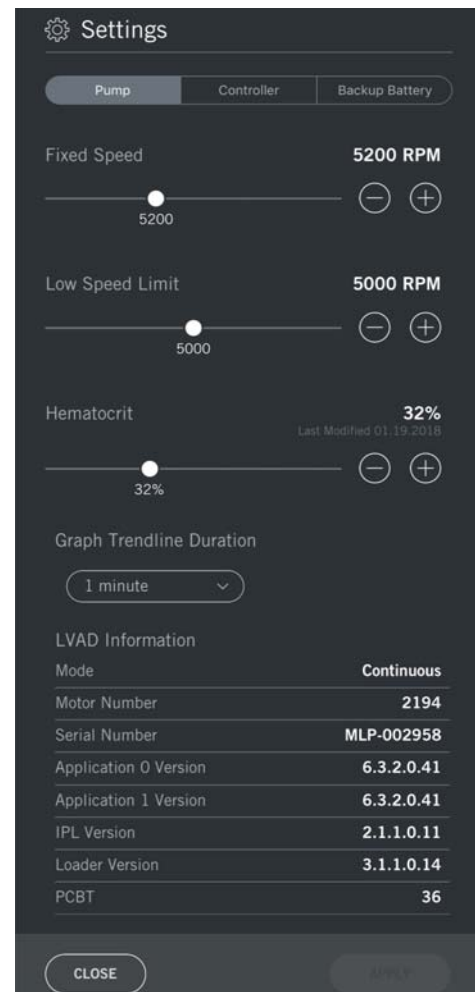

Fixed Speed

The fixed speed is adjustable in increments of 100 rpm, with a range of 3,000 to 9,000 rpm. A low speed advisory alarm appears if either the fixed speed has been set 200 rpm or more below the low speed limit, or the System Controller is unable to maintain the speed at or above the low speed limit. This low speed advisory alarm notification is always provided on the HeartMate Touch™ App (**Figure 4.26**).

Set the Fixed Speed

1. Tap **–** or **+** or move the slider to decrease or increase the fixed speed.
2. Tap **APPLY** to confirm changes.

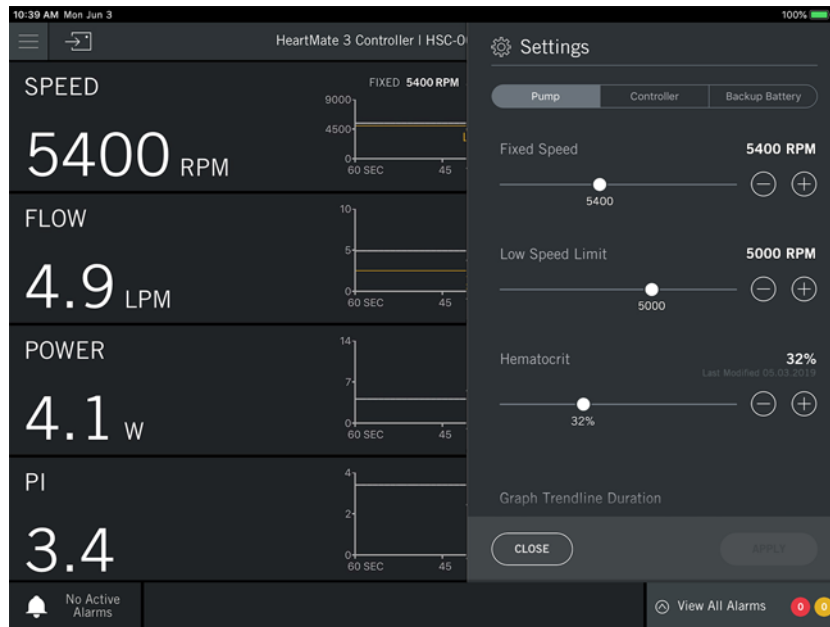

Figure 4.26 Settings Panel with Pump Parameters

These actions have the following conditions.

- **–** —Decreases the fixed speed by increments of 100 rpm. The new value appears above the feature.
- **+** —Increases the fixed speed by increments of 100 rpm. The new value appears above the feature.
- **APPLY** —Accepts the selected fixed speed and returns to the basic Settings panel. A Sending Command message is displayed, and the new set value is sent to the pump.
- **CLOSE** —Returns to the main view. If the fixed speed is changed, yet not applied, you will be prompted to apply or discharge the changes before the settings panel is closed.

IMPORTANT! Tap **APPLY** to save a new speed setting. If another button is used to exit, or if the screen automatically returns to the main view, changes are not saved.

Optimal Fixed Speed

A ramped speed study using echocardiography is the most direct method for determining the optimal fixed speed that will provide the desired level of cardiac support for each patient. The fixed speed setting generally falls midway between the minimum and maximum speeds and is based on changes in ventricular shape and function and the patient's physiological response to changing pump speeds.

Perform a Ramped Speed Study

A ramped speed study is intended for hemodynamically stable, euvolemic patients in the postoperative or later periods. During the study, left ventricular size, position of the septum, and aortic valve opening should be monitored to determine the appropriate fixed speed setting. The final decision is ultimately dependent on the physician's clinical judgment and will vary from patient to patient.

TO DETERMINE THE OPTIMAL FIXED SPEED FOR A PATIENT:

1. With echocardiography available, have the patient sit or lie in a comfortable position.
2. Connect a HeartMate Touch Communication System to the Power Module to adjust the pump speed and monitor pump parameters.
3. Record the patient's current heart rate, blood pressure, and pump speed.
4. Using echocardiography, record the patient's left ventricular diameter, septum's position, and frequency of aortic valve opening.
5. Determine the minimum fixed speed:
 - a. Starting from the current fixed speed, lower the speed gradually to a value as low as possible without the patient experiencing signs of worsening heart failure (eg, shortness of breath, lightheadedness). Allow the patient to stabilize at each speed setting.

IMPORTANT! Do not allow the fixed speed to drop below 3,000 rpm under any circumstances.
 - b. Reduce the speed until the aortic valve opens with each beat or the patient starts to become symptomatic.
 - c. Record the patient's current heart rate, blood pressure, and pump speed.
 - d. Using echocardiography, record the patient's left ventricular diameter and position of the septum.
6. Determine the maximum fixed speed:
 - a. Starting from the minimum fixed speed (determined in Step 5), increase the pump speed gradually until echocardiography shows a flattening of the interventricular septum (or is clinically acceptable based on the echocardiographic evaluation).
 - b. Record the patient's current heart rate, blood pressure, and pump speed.
 - c. Using echocardiography, record the patient's left ventricular diameter and frequency of aortic valve opening.

7. Based on findings from the speed study, determine the optimum fixed speed, which usually falls midway between the minimum and maximum speeds.

IMPORTANT! The selected speed may be adjusted based on clinical judgment regarding the desire for periodic aortic valve opening and a palpable pulse. To accommodate normal shifts in volume and hemodynamic status, the fixed speed should generally be set at least 400 rpm below the maximum fixed speed determined above.

Low Speed Limit

The low speed limit should be set at the lowest speed at which the pump can run while maintaining patient stability. It is important to establish a low speed limit that can sustain a patient safely to maximize the protective benefits during PI events or when the pump is in power saver mode.

In power saver mode, the System Controller slows pump speed to save power. If power is removed or fails, the System Controller gives 15 minutes of full power before entering power saver mode. Note that alarms cannot be silenced while the System Controller is in power saver mode.

Set Low Speed Limit

1. Tap **−** or **+** or move the slider to decrease or increase the low speed limit (**Figure 4.27**).
2. Tap **APPLY** to confirm the changes.

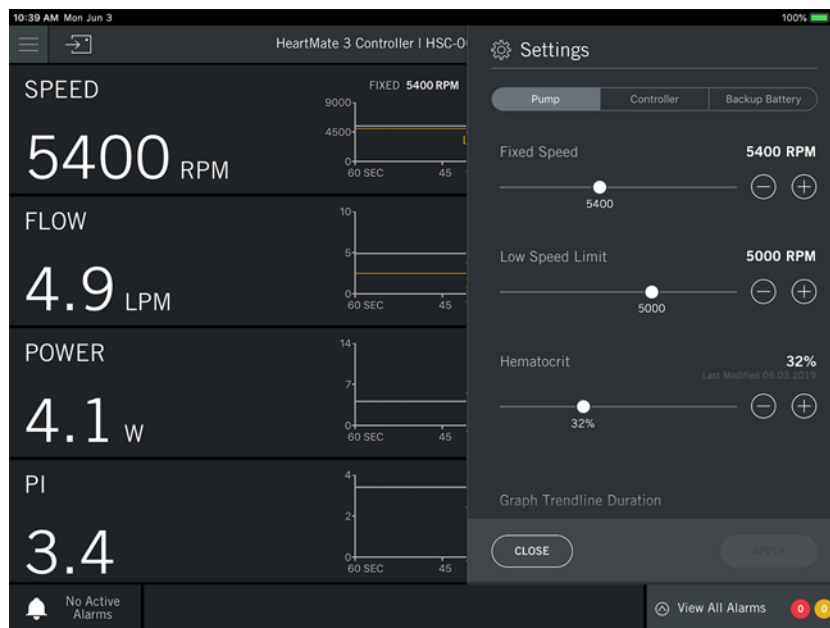

Figure 4.27 Settings Panel to Set Low Speed Limit

The low speed limit is generally set at a value slightly above the minimum speed determined during the speed ramp study discussed above. Clinical judgment and consideration of all factors should be used when selecting the low speed limit.

The low speed limit default setting is 5,000 rpm, but it can be adjusted between 4,000 and 6,000 rpm. If the operating speed drops below the value set for the low speed limit, the Low Speed Advisory alarm message appears.

If the system detects a PI event, the pump speed automatically drops to the low speed limit and slowly ramps back up at a rate of 100 rpm per second to the fixed speed setpoint. This drop in speed is accompanied by a reduced pump flow. If the low speed limit is set at a value above or the same as

the fixed speed setpoint, the pump speed does not change during a PI event. There are no audible alarms with a PI event.

PI events are assumed by the system during cases when there are sudden and substantial changes in the pulsatility index. These events are also referred to as PI events, and may be initiated for reasons other than true PI events. Some reasons include sudden changes in a patient's volume status, arrhythmias, sudden changes in power, and sudden changes in pump speed. These types of PI events are more likely to be triggered in cases of low pulsatility.

Hematocrit

The System Controller provides an estimate of blood flow out of the pump. To provide a more accurate estimate, the System Controller uses the patient's hematocrit level as a surrogate for the patient's blood viscosity. Viscosity is a fluid property that can influence the flow estimate algorithm.

The HeartMate 3 pump has a default hematocrit value of 32%. To assure the most accurate flow estimation from the pump, enter the patient's actual hematocrit % via the Settings panel as shown in **Figure 4.28**.

The initial hematocrit value may be entered using pre-op hematocrit values. Periodic assessment of the patient's hematocrit should be conducted and adjustments made to the stored value in the System Controller as required (e.g., during post-operative recovery, pre-hospital discharge, at hospital discharge, periodic clinic visits).

Set Hematocrit Level

1. Tap **–** or **+** or move the slider to decrease or increase the hematocrit (**Figure 4.28**).
2. Tap **APPLY** to confirm the changes.

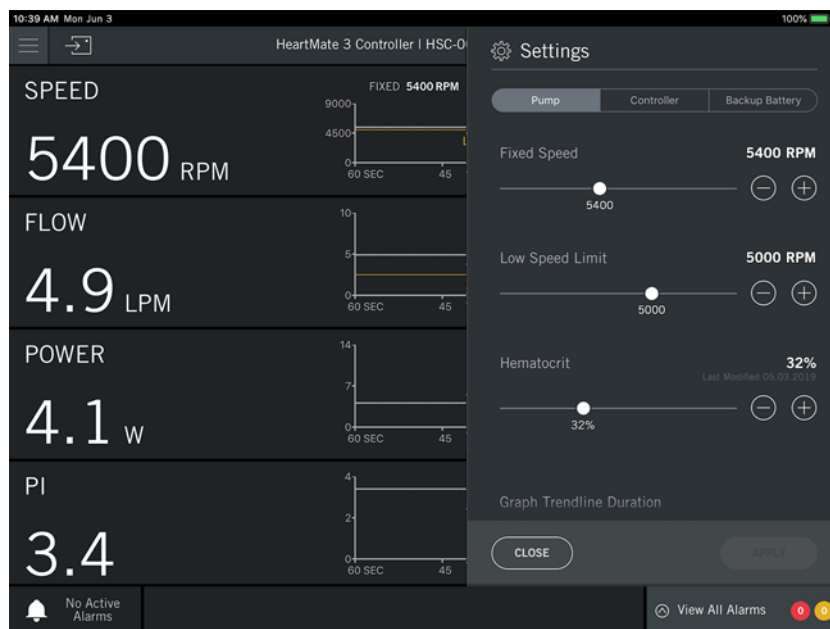

Figure 4.28 Settings Panel

Prime Pump

The Prime Pump button is only available for use in the implant procedure to prepare the pump for implant. It is available only when the Settings panel is opened from the Clinical view. See *Preparing, Running, and Priming the Pump* on page 5- 25 for more details.

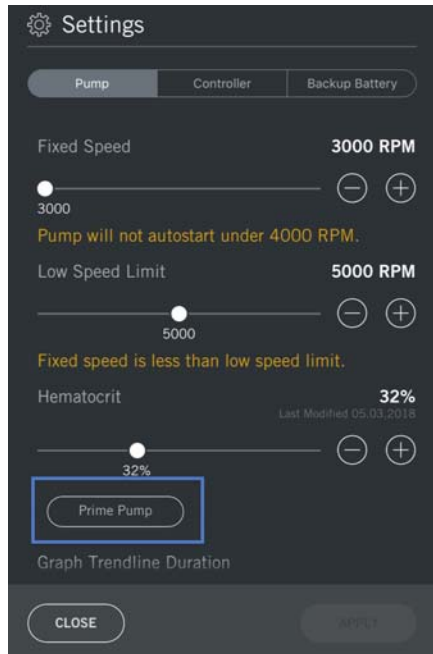

Figure 4.29 Prime Pump

Graph Trendline Duration

Graph Trendlines are displayed on the Clinical and Monitor views to track pump parameters. The four pump parameters that have graph trendline durations: 1. Speed, 2. Flow, 3. Power, 4. PI. The graph trendline duration controls the maximum amount of time displayed on the graph at a given time. When the time is exceeded the most recent information will remain on the graph and the older information is removed from the graph.

1. Scroll through the graph trendline duration options.
2. Tap **APPLY** to update the setting.



Figure 4.30 Graph Trendline Duration and LVAD Information

LVAD Information

The LVAD Information section provides LVAD specifics such as pump mode, serial number, and software versions.

Controller Tab

The Controller tab lets you access System Controller parameters and view detailed System Controller information.

Controller Date & Time. The System Controller date and time can be synced to the Tablet date and time or entered in manually. Refer to *Controller Date & Time* on page 4-33.

Periodic Logs. Both the System Controller and the LVAD can be configured to log the system parameters and status at a set frequency of time. The logged system parameters can be viewed in the historical view. Refer to *System Controller Periodic Log*, *LVAD Periodic Log* on page 4-36.

Controller Language. Allows the user to select the language for on-screen messages. See *System Controller Language* on page 4-37.

Controller Information. The Controller Information section provides System Controller specifics such as serial number and software versions.

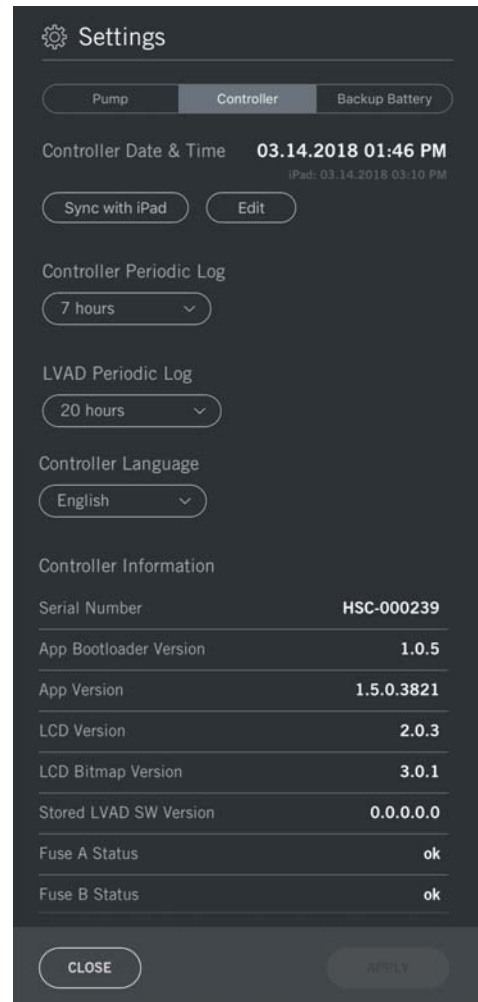

Controller Date & Time

The Tablet and System Controller have separate clocks and can be set independently from each other. The current date and time stored in the System Controller is displayed to the right of the Controller Date & Time settings. The current Tablet date and time is displayed below the System Controller date and time. The System Controller and LVAD periodic and event logs always reflect the date and time on the System Controller's clock.

The System Controller date and time can be synchronized with the Tablet date and time, or it can be entered in manually.

Synchronize System Controller and Tablet Date and Time

1. On the Tablet, tap **Settings** (⚙️) > **General** > **Date & Time**.
2. Visit www.apple.com to get help with the date and time on your Tablet.

Synchronize System Controller and Tablet Date and Time

1. Tap **Settings** (⚙️) > **Controller**. View the Tablet date and time to ensure that it is correct.

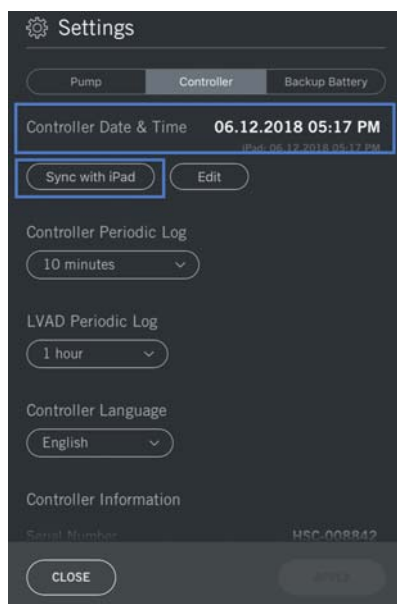

Figure 4.31 Controller Date & Time, Sync with iPad‡

2. Tap **Sync with iPad**. A confirmation to synchronize the System Controller with the iPad message appears.

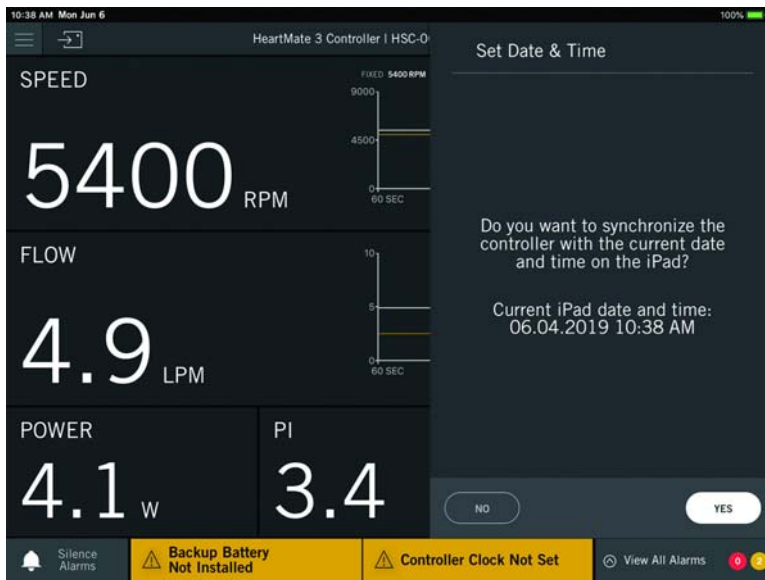

Figure 4.32 Confirm Message

3. Tap **YES**. The System Controller date and time will be updated to match the Tablet date and time and will be displayed to the right of the Controller Date & Time setting.

Edit System Controller Date and Time

1. Tap **Settings** (⚙️) > **Controller**. This panel appears (**Figure 4.33**).

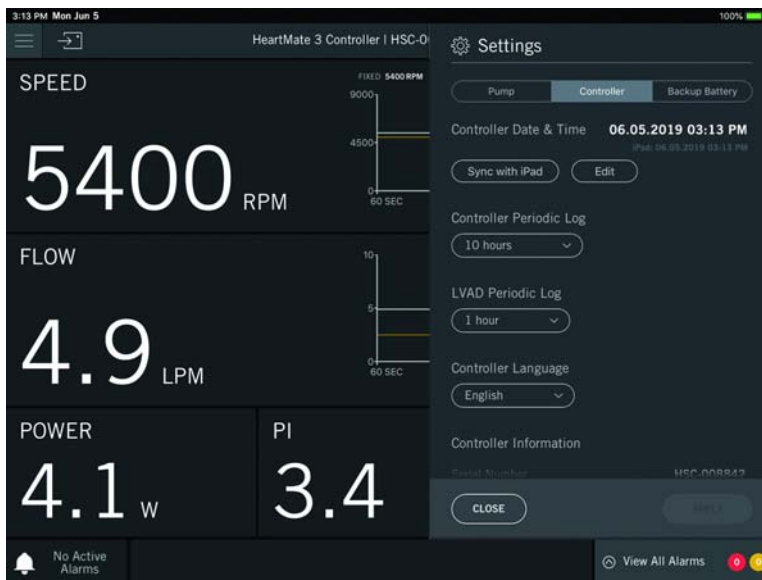

Figure 4.33 Set Date and Time

2. Tap **Edit**. The Set Date & Time controls appear. (**Figure 4.34**)



Figure 4.34 Confirm Date and Time

3. Set the date, time, and year; and then tap **APPLY**. The updated System Controller date and time is displayed to the right of the Controller Date & Time setting.

System Controller Periodic Log, LVAD Periodic Log

Both the System Controller and LVAD Periodic Logs can be configured to take a “snapshot” of system performance parameters at a set frequency of time. The System Controller and LVAD can record 256 periodic logs. When the log is full, the oldest record is replaced with the newest record.

The Settings Panel Controller Tab is used to change the rate at which data is recorded for both the System Controller and LVAD periodic logs. The current frequency will be displayed in the button.

1. Tap **Settings** (⚙️) > **Controller**.
2. Tap the **Controller Periodic Log** or **LVAD Periodic Log** duration drop-down.

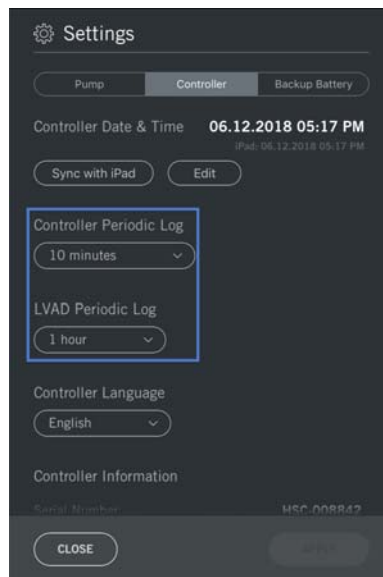

Figure 4.35 Period Settings

3. Select the desired duration. Frequencies includes 10 minutes, 20 minutes, 30 minutes, and 1 hour to 24 hours in one hour increments. Tap **APPLY**.

System Controller Language

The System Controller's on-screen messages are available in multiple languages. Available languages are listed in alphabetic order. The current language in use on the System Controller is displayed on the Controller tab of the Settings panel (**Figure 4.36**).

Set System Controller Language

1. Tap **Settings** (⚙️) > **Controller**.
2. Tap the Controller Language drop-down (📄). The language control appears.
3. Select a language. Tap **APPLY**.



Figure 4.36 System Controller Information Panel

Controller Information

The Controller tab has specific System Controller information (serial number, hardware and software versions).



Figure 4.37 Controller Information

Backup Battery Tab

The Backup Battery tab provides information on the System Controller 11 Volt Lithium-Ion backup battery.

Backup Battery Information. The backup battery inside the System Controller can power the pump for at least 15 minutes during a power loss emergency. Certain items (Serial Number, Manufacture Date, Maximum Time, Maximum Service Life, and Maximum Shelf Life) are backup battery fixed characteristics.

Other items (Last Full Recharge Date, Cumulative Time, Patient Use, and Replace Information) are variable and change with backup battery use.

Status of the 11 Volt Lithium-Ion Backup Battery

Patient use. Total number of times that the System Controller's 11 Volt Lithium-Ion backup battery has been used. Frequent use may indicate that a patient is having difficulty changing from the Power Module to battery power or vice versa.

Replace Information. Indicates the number of months remaining before the System Controller 11 Volt Lithium-Ion backup battery expires.

Cumulative Time. The total number of minutes that the System Controller 11 Volt Lithium-Ion backup battery has been used. High numbers may indicate that a patient is inappropriately relying on the backup battery for non-emergency support.



Backup Battery Information	
Status	Installed
Serial Number	SR179-042
Manufacture Date	06.28.2017
Maximum Time	10950 minutes
Maximum Service Life	36 months
Maximum Shelf Life	24 months
Last Full Recharge Date	03.02.2017
Cumulative Time	36 minutes
Patient Use	17 times
Replace Information	27 months

Figure 4.38 Backup Battery Tab

Alarms

Alarm Status Bar



IMPORTANT! When more than two alarms occur simultaneously, you must go to the View All Alarms Panel to view all active alarms. See *Hazard Alarms* on page 4- 45 and *Advisory Alarms* on page 4-46 for explanations of the conditions leading to each HeartMate Touch App alarm.

The alarm status bar displays the current alarm silence status, the two highest priority active alarms, the number of active hazard and advisory alarms, and access to view all hazard and advisory alarms. It is displayed at the bottom of all views.



Figure 4.39 Alarm Status Bar

Alarm Silence

You can silence active alarms by tapping  **Silence Alarms**. This action will temporarily silence the alarm on both the System Controller and the Power Module. Tap  **Silence Alarms** to silence all Hazard and the Power Cable Disconnected alarms for two minutes, the Low Voltage Advisory alarm for 5 minutes, and all other Advisory alarms for four hours. The exceptions are Communication Fault, Driveline Power Fault, Driveline Communication Fault, which can be silenced indefinitely or for 24 hours.

Tap  **Silence Alarms** and the alarms will be temporarily silenced and *Alarm Silence is On* will be displayed (see **Figure 4.40**).



Figure 4.40 Alarm Silence is On

Note: The Silence Alarm button cannot be tapped on the HeartMate Touch™ App for a few seconds while the pump is in the process of starting and stopping, due to a start pump or stop pump command. The Silence Alarm button may still appear for alarm conditions for which there is no associated audible alarm. In this case, the button will not perform any function.

Once the pump has completed starting or stopping, the Silence Alarm button will become available.

Alarm Silence Status

- **No Active Alarms.** No alarms are active.

- **Silence Alarms.** There are one or more active audio alarms that can be silenced by tapping  **Silence Alarms.** You can also press the silence alarm button on the System Controller.
- **Alarm Silence is On.** One or more active alarms have been silenced.
- **Extended Silence is On.** All Hazard and Advisory audio alarms have been silenced for four hours. See *Extended Alarm Silence* on page 4- 43.

Active Alarms

The two active highest priority alarms are displayed at the bottom center of the screen. Hazard alarms are designated by red backgrounds and advisory alarms are designated by yellow backgrounds. To view all active and inactive alarms, tap **View All Alarms**.



Figure 4.41 Alarms Panel

View All Alarms

1. Tap **View All Alarms**. The Alarms panel appears (**Figure 4.42**).

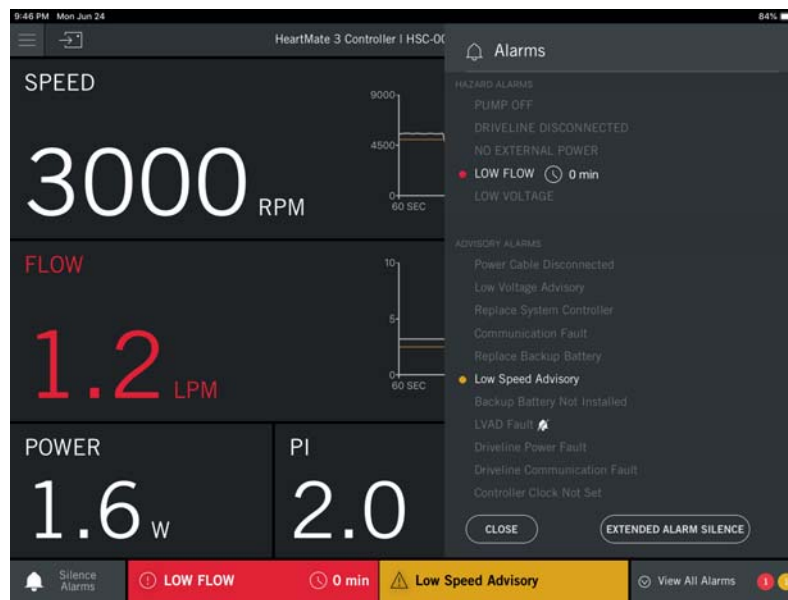

Figure 4.42 Alarms Panel

The Alarms panel displays the following information.

- **Alarm messages.** All alarms (active and inactive) are displayed in the Alarms Panel in order of highest priority from top to bottom.
 - Active alarms are highlighted white and have a red dot (■) for hazard alarms.
 - Advisory alarms have a yellow dot (■).

Inactive alarms remain gray. If there are multiple active alarms, the active alarms will be highlighted at the same time.

- **Extended Alarm Silence.** This feature is available when there are active audible alarms and the Fixed Speed is set below 4,000 rpm. Tap **Extended Alarm Silence** to silence all Hazard and Advisory alarms for four hours.

Extended Alarm Silence

At fixed speeds set below 4,000 rpm and with any active alarm, Extended Alarm Silence is available. Use this feature to silence all Hazard and Advisory alarms on the Power Module and System Controller for four hours. During this time alarm messages continue to display even though the audible alarm is silent.

Enable Extended Alarm Silence

1. Tap **View All Alarms.**

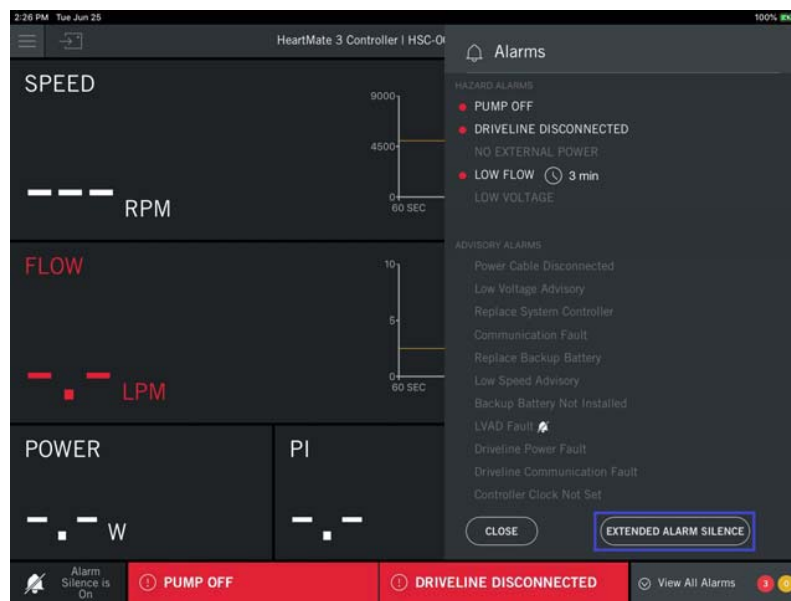

Figure 4.43 Extended Alarm Silence

2. Tap **EXTENDED ALARM SILENCE**. An override alarms confirmation message appears.

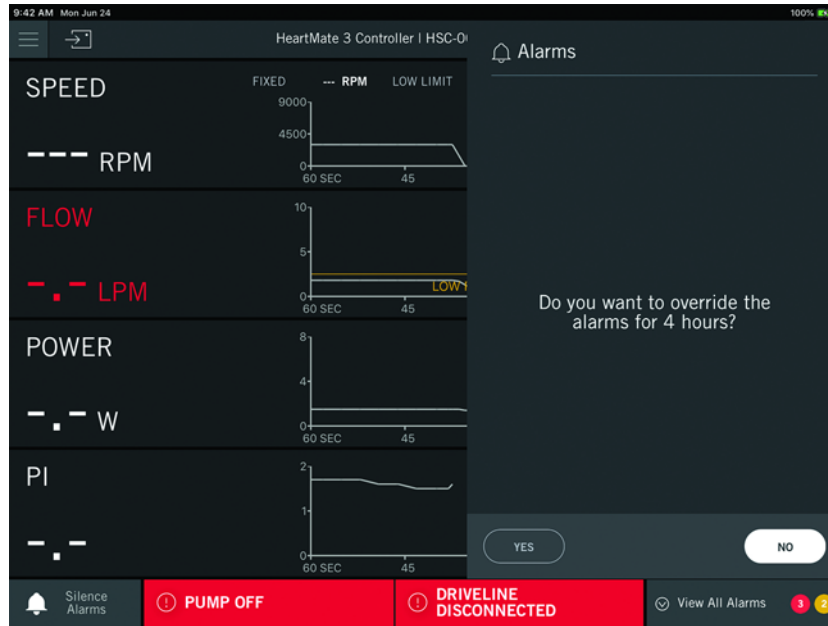

Figure 4.44 Extended Alarm Silence

3. Tap **YES** to confirm that extended silence should be enabled.

IMPORTANT! If the Silence Alarm button on the System Controller is pressed, the HeartMate Touch Communication System's extended silence is canceled.

Hazard Alarms

Hazard alarms occur for conditions that are potentially life threatening for the patient. Hazard alarms require immediate attention.

Note: All Hazard Alarms are designated by red backgrounds. On-screen messages for Hazard alarms are accompanied by a continuous audio tone from the System Controller.

IMPORTANT! If communication is lost between the System Controller and the Pump, this causes a Controller Fault Hardware Hazard alarm. This alarm will only be displayed on the System Controller and not on the HeartMate Touch App.

The five hazard alarms are listed here in order of priority:

- **PUMP OFF**—The pump has been turned off or its Driveline is disconnected from the System Controller. Immediately turn on the pump or reconnect the Driveline to the System Controller.
- **DRIVELINE DISCONNECTED**—The Driveline is disconnected from the System Controller. Immediately reconnect the Driveline to the System Controller.
- **NO EXTERNAL POWER**—The System Controller is not receiving external power from either power cable, and pump function is being supported by the System Controller's backup battery. Immediately connect the System Controller to a power source (Power Module, Mobile Power Unit, or two HeartMate 14 Volt Lithium-Ion batteries).
- **LOW FLOW X min**—Pump flow is less than 2.5 liters per minute (LPM), the pump has stopped, the pump is not operating properly, or the Driveline is disconnected from the System Controller. The count up time listed in the parameters box indicates how long this alarm has been active. Changes in patient conditions can result in low flow, such as hypertension.
- **LOW VOLTAGE**—Less than five minutes of combined power remain for the two HeartMate 14 Volt Lithium-Ion batteries (during battery-powered operation), or the System Controller is receiving inadequate power from the Power Module or Mobile Power Unit. Immediately connect the System Controller to a functioning power source.

Advisory Alarms

Advisory alarms are used to inform users about conditions that affect optimal system operation. Although important, Advisory alarms are not related to life threatening risks.

Note: All Advisory Alarms are designated by yellow backgrounds when they appear in the Alarm Status bar.

The eleven Advisory alarms are listed here in order of priority:

- **Power Cable Disconnected**—One of the System Controller power cable connectors (white or black) is broken or disconnected from power (the Power Module or two HeartMate 14 Volt Lithium-Ion batteries). Immediately connect the indicated power cable to a power source.
- **Low Voltage Advisory**—Less than 15 minutes of combined power remain for the two HeartMate 14 Volt Lithium-Ion batteries (during battery-powered operation), or the System Controller is receiving inadequate power from the Power Module. Immediately connect the System Controller to a functioning power source.
- **Replace System Controller**—Indicates the need for clinician assistance and may be a sign of a System Controller malfunction. Ultimately, the alarm may not be able to be resolved, necessitating the replacement of the running System Controller with the backup System Controller (see *Replacing the Current System Controller* on page 2-54). After successfully switching to the backup System Controller, return the faulted System Controller to Abbott for diagnosis.
- **Communication Fault**—The data transfer between the LVAD and the System Controller has been lost due to a problem with the internal communication system or the primary and back-up communication wires in the Driveline are not functioning. Use the HeartMate Touch App to silence the alarm while awaiting resolution, if needed. Also, exchanging the Modular Cable of the Driveline may resolve the problem (see *Replacing the Modular Cable* on page 2-62). If exchanging the Modular Cable does not correct the alarm, contact Abbott to determine the best next steps.
- **Replace Backup Battery**—This alarm could be a sign that the 11 Volt Lithium-Ion backup battery inside the System Controller is compromised or unable to fully support pump function. Promptly replace the faulted battery (see *Replacing a Backup Battery in the System Controller* on page 2-40).
- **Low Speed Advisory**—Either the fixed speed has been set 200 rpm or more below the low speed limit, or the System Controller is unable to maintain the speed at or above the low speed limit.
- **Backup Battery Not Installed**—Either the System Controller's 11 Volt Lithium-Ion backup battery has not been installed, the connection between the backup battery and System Controller is not being made, or the backup battery is damaged or malfunctioning. See *Installing the Backup Battery in the System Controller* on page 5-62.
- **LVAD Fault**—The LVAD has determined that one or more operating parameters is out of range. Contact Abbott to determine best next steps. Use the HeartMate Touch App to silence the alarm while awaiting resolution, if needed.

- **Driveline Power Fault**—One of the redundant power handling wires inside the Driveline may be damaged or broken. Contact Abbott to determine best next steps. Use the HeartMate Touch App to silence the alarm while awaiting resolution, if needed.
Note: The alarm must be the highest priority active alarm to access the alarm silence.
- **Driveline Communications Fault**—One of the redundant communication handling wires inside the Driveline may be damaged or broken. Contact Abbott to determine best next steps. Use the HeartMate Touch App to silence the alarm while awaiting resolution, if needed.
Note: The alarm must be the highest priority active alarm to access the alarm silence.
- **Controller Clock Not Set**—The System Controller's clock has not been set via the HeartMate Touch App Settings panel. See *Controller Date & Time* on page 4- 33.



Figure 4.45 Alarms Panel with Multiple Active Alarms

Note: If necessary, contact Abbott to determine best next steps. Refer to the *Back Cover* of this manual for Abbott contact information.

Driveline Power Fault Alarm

Follow the instructions below to clear or silence an active Driveline Power Fault alarm. This alarm must be the only fault that is active, or active concurrently with the Driveline Communication Fault and/or LVAD Fault alarms.

- Enable Permanent Silence – This action will permanently silence the audio portion of the Driveline Power Fault alarm, and the System Controller will no longer display this alarm. The visual alarm on the HeartMate Touch App is maintained. To silence the alarm, access the HeartMate Touch App Alarm panel and tap **Enable Permanent Silence**. See **Figure 4.46**.
- Clear Alarm – Clearing this alarm resets the alarm status from active to inactive. To clear the alarm, access the HeartMate Touch App Alarm panel and tap **Clear Alarm**. If the alarm condition persists, this alarm will be reactivated. If it was a transient condition, this alarm will not be reactivated. See **Figure 4.46**.

Clear or Permanently Silence Driveline Power Fault Alarm

1. Tap **View All Alarms**.
2. Tap the Driveline Power Fault drop-down (☑) to display additional buttons.
3. Tap **Enable Permanent Silence** or **Clear Alarm**.

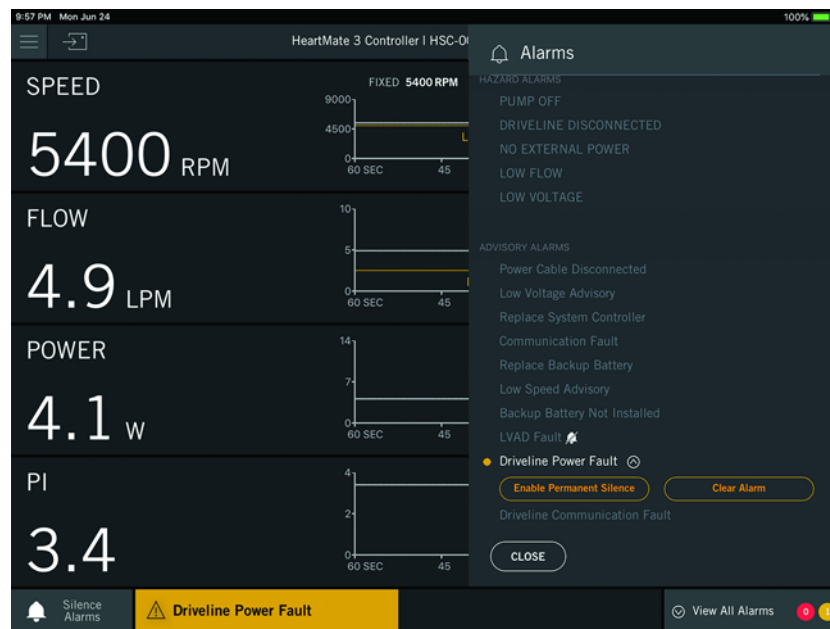



Figure 4.46 Driveline Power Fault Alarm Buttons

Driveline Communication Fault Alarm

Follow the instructions below to clear or permanently silence an active Driveline Communication Fault alarm. This alarm must be the only fault that is active, or is active concurrently with the Driveline Power Fault and/or LVAD Fault alarms.

- Enable Permanent Silence – This action will permanently silence the audio portion of the Driveline Communication Fault Alarm. The System Controller will no longer display this alarm. The visual alarm on the HeartMate Touch App is maintained. To silence the alarm, access the HeartMate Touch App Alarm panel and tap **Enable Permanent Silence**. See **Figure 4.47**.
- Clear Alarm – Clearing this alarm resets the alarm status from active to inactive. To clear the alarm, access the HeartMate Touch App Alarm panel and tap **Clear Alarm**. If the alarm condition persists, this alarm will be reactivated. If it was a transient condition, this alarm will not be reactivated. See **Figure 4.47**.

Clear or Silence Driveline Communication Fault Alarm

1. Tap **View All Alarms**.
2. Tap the Driveline Communication Fault drop-down () to display additional buttons.
3. Tap to **Enable Permanent Silence** or **Clear Alarm**.

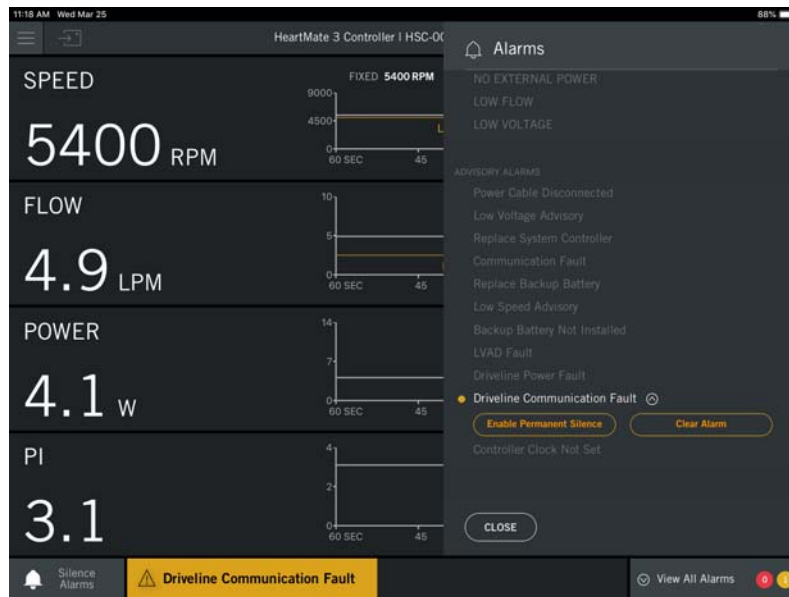

Figure 4.47 Driveline Communication Fault Buttons

Pump Parameters

All views (Clinical, Monitor, Historical) display the pump parameters (Speed, Flow, Power, and PI) and pump settings (Fixed Speed, Low Speed Limit and Hematocrit).

Pump Speed

The HeartMate Touch™ App displays the pump speed in revolutions per minute (RPM). This value matches the actual speed within ± 100 rpm under nominal conditions (**Figure 4.48**).

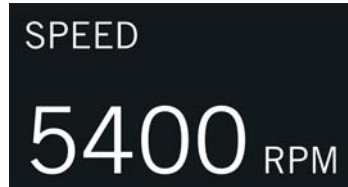

Figure 4.48 Pump Speed is Displayed in RPM

If the pump is disconnected from the System Controller or a Communication Fault alarm occurs, the HeartMate Touch App displays speed as "--- RPM" (**Figure 4.49**).

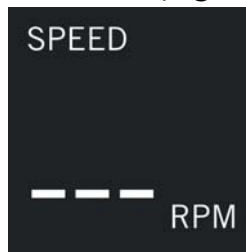

Figure 4.49 Speed Display when the Pump Driveline is Disconnected or Communication Fault Exists

When the pump is stopped by tapping **STOP PUMP**, the speed is zero and displays as "--- RPM" (**Figure 4.50**).

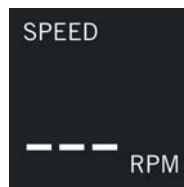

Figure 4.50 Pump Stopped with Driveline Connected

Pump Flow

The System Controller provides an estimate of blood flow out of the pump. This estimate is based on pump speed and the amount of power being provided to the pump motor. The relationship between power and flow at any particular speed is mostly linear.

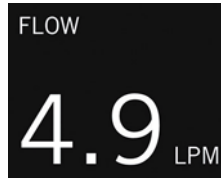

Figure 4.51 Pump Flow Display

Pump Flow (FLOW) displays "-.- LPM" (**Figure 4.52**) when any of these conditions occur:

- The estimated pump flow is outside the expected operational range (less than 4000 rpm AND a PI greater than 9.0).
- The driveline is disconnected.
- There is a Communication Fault alarm.

If the flow estimate falls outside the expected operational range or acceptable linear region, a LOW FLOW alarm is triggered and FLOW displays "-.- LPM" as shown in **Figure 4.52**. This situation only occurs when SPEED is below 4000 rpm AND the Pulse Index (PI) is greater than 9.0. This condition prevents the display of inaccurate flow information.

Under the following conditions, the pump can only be started from the HeartMate Touch App Clinical view by tapping **START PUMP**:

- The fixed speed setting is below 4,000 rpm.

AND

- The System Controller's backup battery is not installed.

If the pump stops because the Driveline is disconnected from the System Controller, the pump restarts at the previously set speed when the Driveline is reconnected, if:

- The fixed speed setting is at least 4,000 rpm.

OR

- The System Controller's backup battery is installed and any button is pushed on the System Controller.



Figure 4.52 LOW FLOW Alarm and Pump Flow

When the Driveline is disconnected from the System Controller, FLOW displays "-.- LPM". This condition is accompanied by these Hazard alarms: PUMP OFF, DRIVELINE DISCONNECTED. START PUMP appears greyed out in the bottom right corner (**Figure 4.53**) in the Clinical view only.

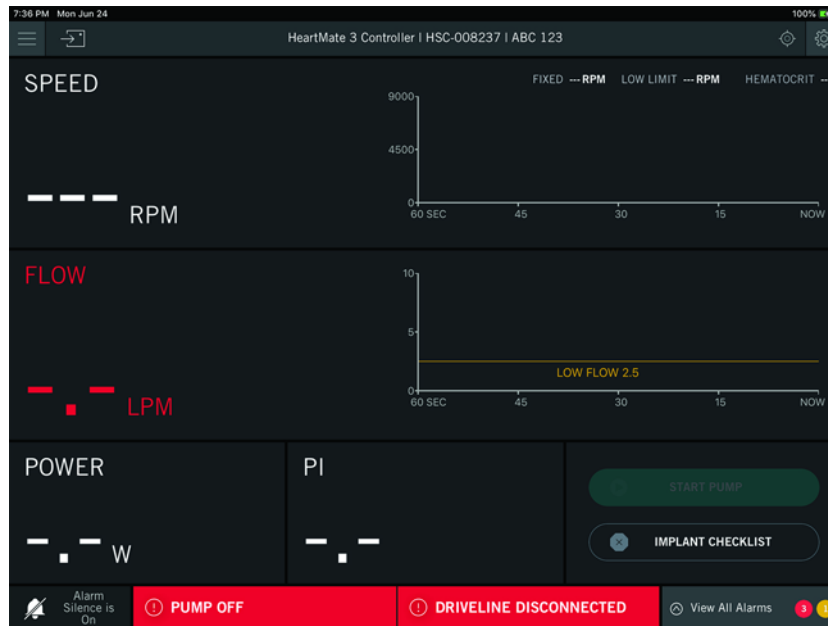

Figure 4.53 Alarms When Driveline is Disconnected

Pump Power

The Power region displays pump power. Pump power is the amount of power being provided to the pump motor. Pump power ranges between 0.0 to 25.5 watts (**Figure 4.54**).

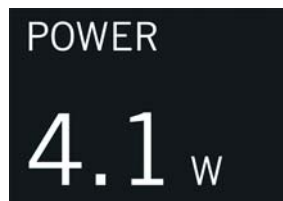

Figure 4.54 Pump Power

When the Driveline is disconnected from the System Controller, “-.w” appears under Power (**Figure 4.55**).

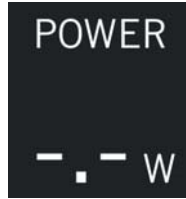

Figure 4.55 Power when Driveline is Disconnected

Pulsatility Index

Pulsatility Index (displayed as PI) is a calculation related to the amount of assistance that is provided by the pump. PI values typically range from 1 to 10. Higher values indicate higher pulsatility (that is, the pump is providing less support and the heart is providing more support). Lower values indicate lower pulsatility (that is, the pump is providing more support and the heart is providing less support). Pulsatility Index appears in all views (**Figure 4.56**).

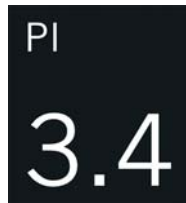

Figure 4.56 Pulsatility Index

When the pump is stopped or the Driveline is disconnected from the System Controller, "-.-" appears under PI (**Figure 4.57**).

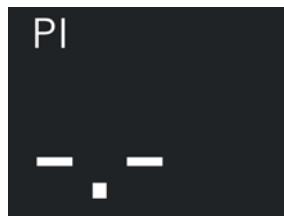

Figure 4.57 Pulsatility Index when Pump is Stopped

Monitor View

The Monitor View (**Menu** (☰) > **Monitor**) is the first view displayed when the HeartMate Touch™ Communication System is connected to the HeartMate™ LVAS.

It displays Pump parameters (Speed, Flow, Power, and PI) with trendlines. It also displays pump settings (Fixed Speed, Low Speed Limit, and Hematocrit). The Monitor View also has a Reminders panel (right) that provides reminders. A typical reminder might remind you to replace the System Controller Backup Battery. The System Controller Backup Battery expiration status is only displayed when a backup battery is installed and the System Controller clock is set.

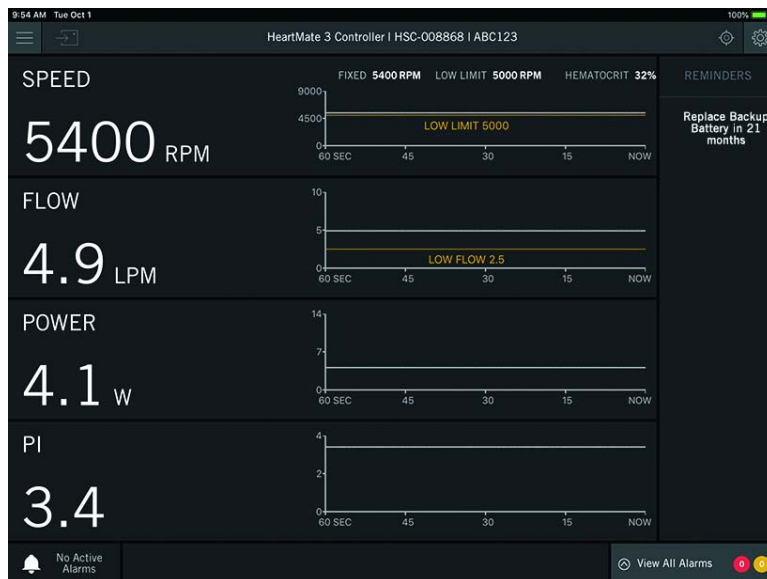

Figure 4.58 Monitor View

The Reminders Panel displays three different messages depending on the status of the Backup Battery:

Replace Backup Battery in X Months (White Text Display). The Backup Battery is more than 6 months from expiration. X is the number of months remaining before the backup battery expires.

Replace Backup Battery in X Months (Orange Text Display). The Backup Battery is less than 6 months from expiration and should be replaced.

Replace Backup Battery. The Backup Battery is less than 1 month from expiration, has expired, there is a Backup Battery Fault, or the Backup Battery is not installed. A new Backup Battery should be installed.

Clinical View

The Clinical view (tap **Menu** (☰) > **Clinical**) displays the primary operating parameters, parameter settings, and trendline information for speed and flow only. The Pump Parameter value's font size is slightly larger than the Monitor view. The Clinical view is used during the implant procedure as it is the only view that provides information on starting, priming, and stopping the pump.

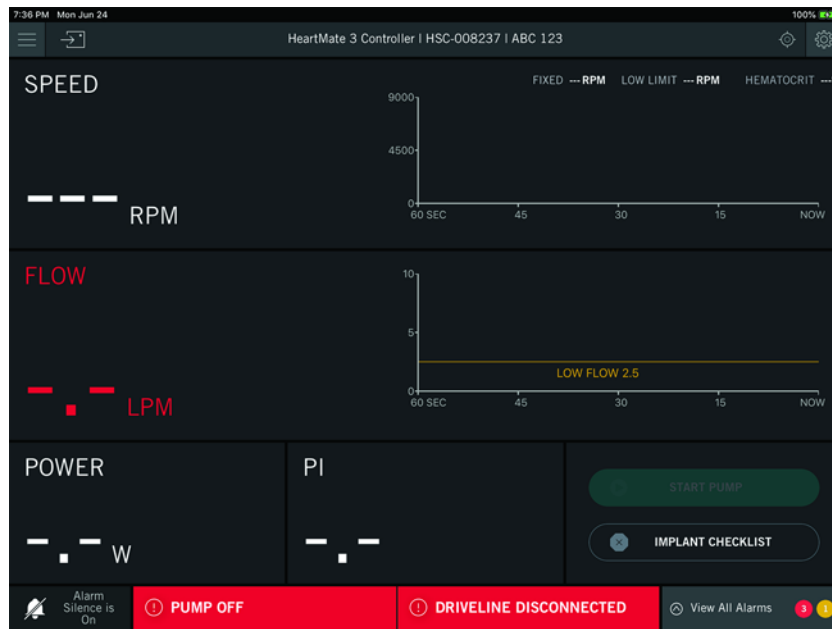

Figure 4.59 Clinical View

Start Pump

The Start Pump button is only accessible from the Clinical view. The Start Pump button is displayed when the pump is off and connected to the System Controller.

Start the Pump

1. Check the Fixed Speed and adjust it as necessary. Refer to *Fixed Speed* on page 4-24 for instructions.
2. Tap **START PUMP** to start the pump. A start pump confirmation message appears as shown in **Figure 4.60**.

IMPORTANT! The pump will remain off until you tap **START PUMP**.



Figure 4.60 Pump Start Message

3. Tap **START PUMP**.

When the pump is running, the Start Pump panel will close and the Clinical view will be displayed. The **START PUMP** button is changed to a **STOP PUMP** button.

IMPORTANT! If you tap **CANCEL** in response to "Are you sure you want to start the pump?" the pump will remain off.

Stop Pump

The Stop Pump feature is only accessible from the Clinical view. Stop Pump is displayed when the pump is running.

Stop the Pump

1. Tap **STOP PUMP** to turn off the pump. A stop pump confirmation message appears (**Figure 4.61**).

IMPORTANT! The pump will remain running until the command is confirmed on the next screen.



Figure 4.61 Clinical View with STOP PUMP

Note: If you tap **CANCEL**, the pump remains running at the previously set mode and speed.

2. Tap **STOP PUMP** to confirm. A progress bar appears and the pump will stop within a few seconds.

IMPORTANT! The PUMP OFF alarm appears a few seconds after you tap **STOP PUMP**. This action is accompanied by a continuous audible alarm; unless Extended Silence is on. Active audio alarms cannot be silenced using the HeartMate Touch™ App while the pump is in the process of stopping.

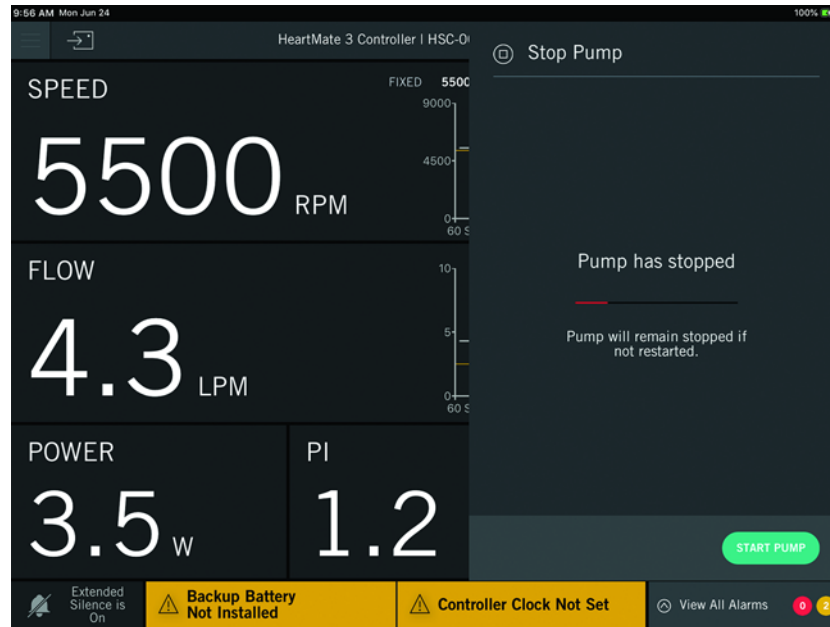



Figure 4.62 Pump Stop Progress Bar

If you tap **START PUMP** while the stop pump progress bar is displayed, the pump will restart and return to the previously set mode and speed. Initially, the Low Speed Advisory alarm and then the LOW FLOW hazard alarm appear, both without an audible alarm.

After the Pump Stop completes, **START PUMP** appears and the pump may be restarted. See *Start Pump* on page 4- 57 for more information.

After the pump has stopped, the Stop Pump panel will close and the Clinical view will be displayed. The **STOP PUMP** feature is changed to **START PUMP**.

3. Tap  **Silence Alarms** on the lower left side of the screen to silence the active audible alarms.

IMPORTANT! If the backup battery is installed in the System Controller, pressing the System Controller Alarm Silence button will restart the pump. Silence audio alarms using the HeartMate Touch App instead.

Restart the Pump

Once the driveline is connected to the System Controller, starting the pump will depend on the fixed speed setting.

Pump Speed < 4000 RPM. Pump start is not automatic.

- System Controller back up battery not installed, tap **START PUMP** on the HeartMate Touch™ App.
- System Controller backup battery installed and external power source available, press any button on the System Controller.

Pump Speed ≥ 4000 RPM. Pump starts automatically.

- System Controller is powered by an external power source. (Power Module, Mobile Power Unit, or 14 volt Lithium Ion batteries)
- The pump will not start if the only power source is the System Controller backup battery.

Implant Checklist

The Implant Checklist provides a list of actions that should be completed at the end of an implant procedure and prior to the patient leaving the operating room.

CAUTION !

Verify that the HeartMate Touch™ Communication System is connected to the intended HeartMate LVAS when making changes to LVAS settings.

Access the Implant Checklist

1. Tap **IMPLANT CHECKLIST**. The Implant Checklist panel appears.

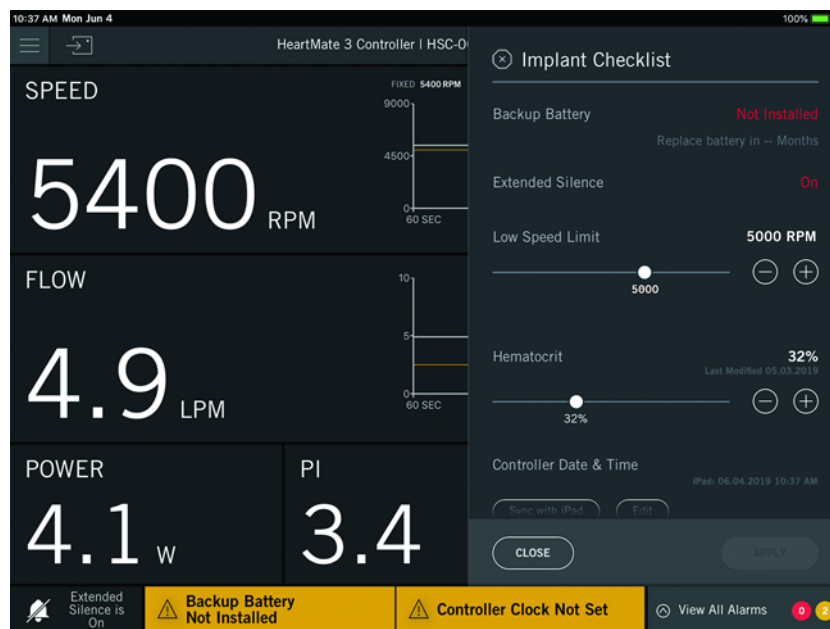



Figure 4.63 Implant Checklist

2. Install the Backup Battery. See *Installing the Backup Battery in the System Controller* on page 5-62.
3. Turn off Extended Silence by pressing the System Controller silence alarm button ().
4. Set the Pump and System Controller settings. See *Pump Tab* on page 4-23 and *Controller Tab* on page 4-32 for more information on pump and System Controller settings.

Historical View

The Historical view displays the data stored in the System Controller event log and periodic log. Pump, Flow, Power, and PI is stored in the System Controller. The LVAD and System Controller event and periodic logs can also be exported to an Abbott approved Flash Drive from this view.

Tap **Menu** (☰) > **Historical**. You will be prompted to confirm loading the data. It may take a few minutes to load the data.

IMPORTANT! While loading data, viewing information and making changes will not be available. If an alarm occurs while loading records or saving data, an audible alarm sounds, but no message is displayed.

The loaded data can be displayed as a graph or table. (**Figure 4.64**)

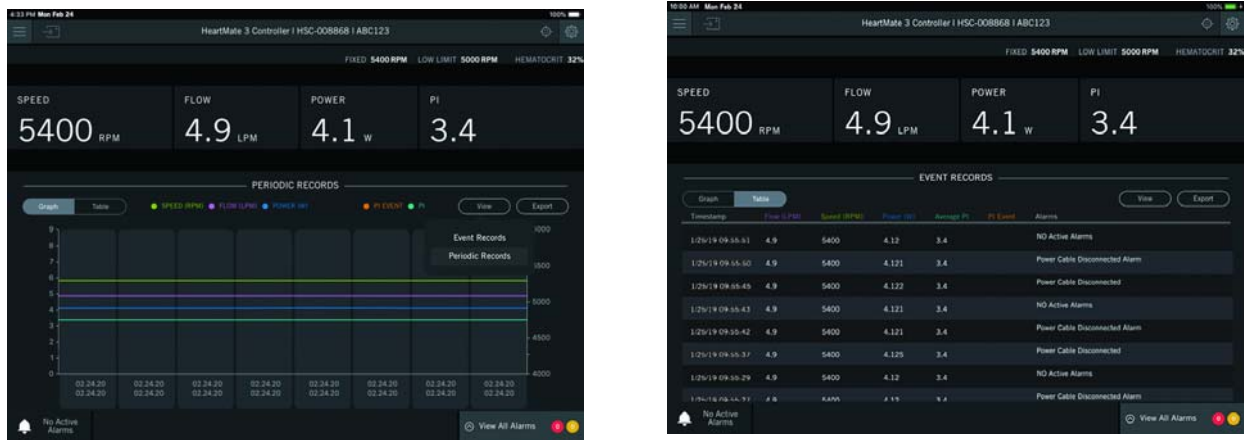

Figure 4.64 Graph Historical View | Table Historical View

The System Controller and the LVAD can be configured to take a snapshot of system performance parameters at a set frequency of time. This data is independent of the System Controller event log, which is initiated by events vs. time. The System Controller and LVAD can record 256 periodic logs. When the log is full, the oldest record is replaced with the latest record.

To set the frequency, see **System Controller Periodic Log, LVAD Periodic Log** on page 4-36.

Event Records | Periodic Records

You can view both event records and periodic records. Records can be displayed as a graph or table.

Event Records. System performance parameters are logged when an event occurs. An event is defined as an alarm, disconnected cable, or pump stop action.

Periodic Records. A periodic record is defined as a log of the system performance parameters at an adjustable interval (e.g., every 10 minutes). The system will display the timestamp that the data was recorded in the table view. e.g., 6/7/19 09:14:02 → 6/7/19 09:24:02

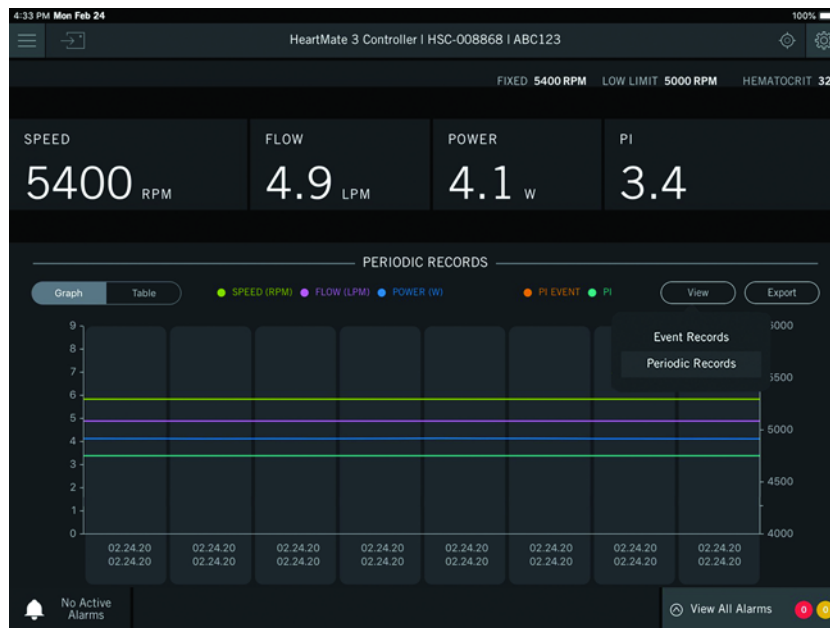

Figure 4.65 View > Event Records or Periodic Records

Tap **View > Event Records**. A graph or table appears that displays a timestamp, along with pump parameters, and alarms. Tap **Graph** to view the event records as a graph.

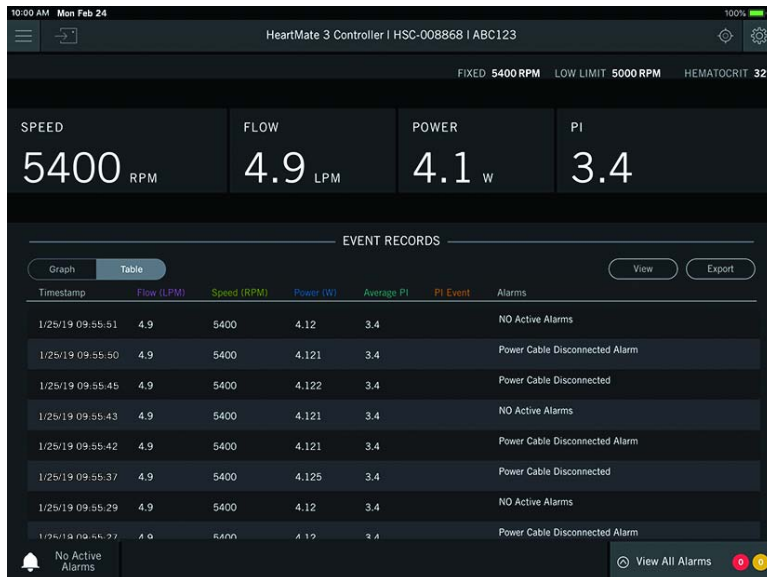

Figure 4.66 Event Records

Figure 4.66 shows event records loaded and displayed as a table. From this view the following features are provided:

- View event records as a graph or table
- View event records or periodic records
- Export data

A maximum of 256 events can be stored and retrieved for display. The event history data are displayed in reverse chronological order with the most recent events at the top.

Sending Information to Abbott

To send data such as HeartMate Log Reports to Abbott for diagnostic purposes, you will need to export the data and save it to a Flash Drive. The iXpand Drive App is necessary so that the data can be sent through e-mail. Follow the instructions in the *HeartMate Touch Communication System Quick Start Guide* to save files to an Abbott approved Flash Drive.

The Flash Drive plugs into any USB port on a personal computer (PC) and acts as a removable drive. Note that the drive designation may differ based on the PC configuration.

IMPORTANT! A PC running Microsoft‡ Windows‡ 2007 or higher is required for most flash drives.

Contact Abbott for the e-mail address to send the data or for further assistance. Refer to the *Back Cover* of this manual for Abbott contact information.

Export Data

Use the export feature to export device data to an Abbott approved Flash Drive.

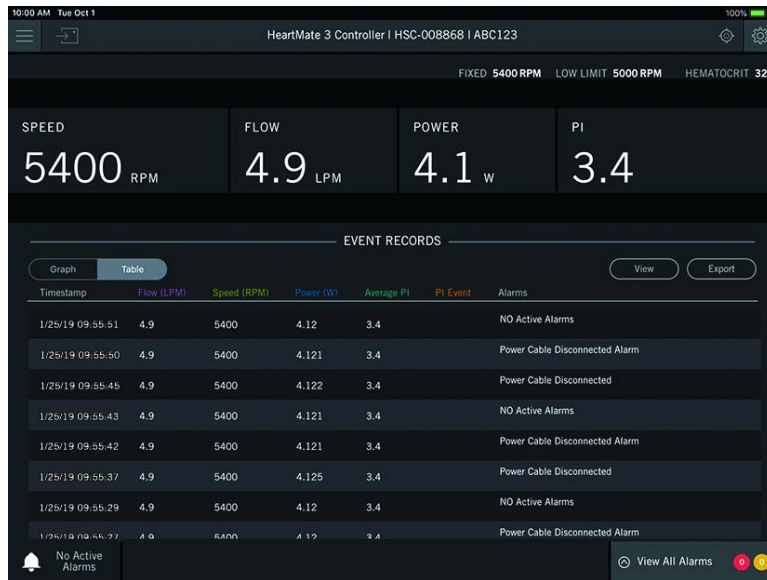

Figure 4.67 Exporting Data Confirmation

1. Tap **Export**. The message below will appear on the screen while exporting data, viewing and making changes message appears.

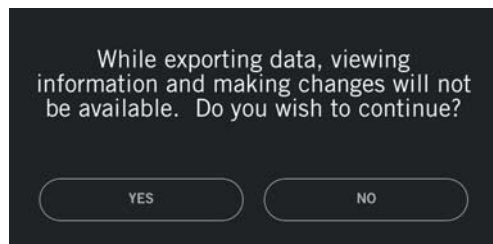

Figure 4.68 Export Data Message

2. Tap **YES**. A window appears prompting you to provide a name.

IMPORTANT! Only create export names that identify the export file. Do not enter any protected health information or individually identifiable health information. Follow your organization's policies, procedures, and employee training that correspond to HIPAA regulatory standards.

IMPORTANT! You should restrict the characters to a through z, 0 through 9, underscores (_), and periods (.).

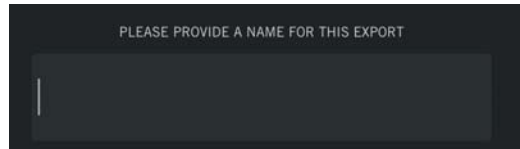

Figure 4.69 Provide Export Name

3. Enter a name for the export (e.g., ABC_123) and then tap **Done**. An exporting data window appears briefly. An export was successful window appears.

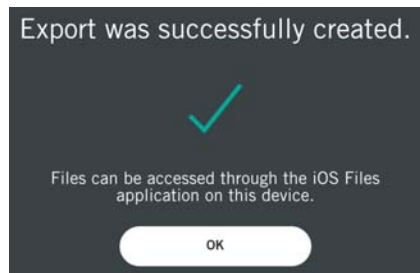

Figure 4.70 Successful Export

4. Tap **OK**. The Historical view appears.

The exported files can now be accessed in the iOS‡ Files application on the Tablet. Follow the instructions in the *HeartMate Touch Communication System Quick Start Guide* to save files to an Abbott approved Flash Drive.

SURGICAL PROCEDURES

This section describes the surgical considerations necessary to prepare, implant, and explant the HeartMate 3™ Left Ventricular Assist System.

Surgical Considerations- - - - -	5-2
Equipment and Supplies Required for Implant - - - - -	5-4
Preimplant Procedures - - - - -	5-7
Unpacking - - - - -	5-10
Unpacking the Pump and Accessories Tray- - - - -	5-12
Preparing the Sealed Outflow Graft - - - - -	5-17
Unpacking the System Controller - - - - -	5-18
Unpacking the Modular Cable - - - - -	5-19
Connecting and Initializing the Sterile System Controller to Non-Sterile Equipment - - - - -	5-22
Preparing, Running, and Priming the Pump- - - - -	5-25
Preparing the Coring Knife - - - - -	5-34
Implant Procedures - - - - -	5-35
Postimplant Procedures - - - - -	5-60

Surgical Considerations

This section describes the preimplant, implant, and explant procedures for the HeartMate 3™ Left Ventricular Assist System.

WARNING !

- Moderate to severe aortic insufficiency must be corrected at time of device implant.
- Before using the Power Module, the hospital's biomedical technician or other personnel trained by Abbott must install the Power Module backup battery.
- A minimum of two fully-charged HeartMate 14 Volt Lithium-Ion batteries, a pair of compatible battery clips, and a System Controller are required during device implant to power the LVAS when the patient is being transferred out of the operating room.
- All users (including clinicians, patients, and caregivers) must be trained on HeartMate 3 power accessories (Power Module, Mobile Power Unit, Battery Charger, and batteries) before use.
- Certain parts of the HeartMate 3 Left Ventricular Assist System are not compatible with other HeartMate systems (such as the HeartMate II™ Left Ventricular Assist System). Only use HeartMate 3 parts with the HeartMate 3 System.
- During the implant process, a complete backup system (implant kit and external components) must be available on-site and in close proximity for use in an emergency.
- During the implant process, a complete HeartMate Touch Communication System backup system must be available on-site and in close proximity for use in an emergency.
- All materials and/or components associated with any other surgical procedure must be either removed or adequately secured so as to not interfere with the operation of the HeartMate 3 Left Ventricular Assist Device.

WARNING ! (Continued)

- The sealed Outflow Graft contains material of bovine origin. It should not be implanted in patients who are sensitive to such materials.
- The manufacturing process for gelatin sealed vascular grafts uses the cross-linking agent formaldehyde to achieve the graft performance. All gelatin sealed grafts are thoroughly rinsed with RO water to reduce residual formaldehyde, however residual amounts may be present in the finished graft. Formaldehyde is also found at low levels naturally in the body, some of which is derived from food. Formaldehyde is known to be mutagenic and carcinogenic. The risks of these potential harms from the product have not been established clinically.
- The HeartMate 3 pump may cause interference with implantable cardiac defibrillators (ICD). If electromagnetic interference occurs it may lead to inappropriate ICD therapy. The occurrence of electromagnetic interference with ICD sensing may require adjustment of device sensitivity and/or repositioning the lead.
- Keep connectors clean and dry and away from water or liquid. If the connectors come into contact with water or liquid, the system may fail to operate properly or you may get a serious electric shock.
- Do not use the HeartMate 3 Left Ventricular Assist Device in pregnant women or in women likely to become pregnant. A growing fetus may dislodge the Pump, which may result in device failure, catastrophic bleeding, or death. Instruct women of childbearing age to use reliable contraception if sexually active. Blood thinners have been associated with birth defects. Anticoagulation regimens are contraindicated during pregnancy.
- Do not apply high power mains treatment (eg, application of diathermy) directly to the patient. Application of high power mains treatments could result in mains interference with system operation, causing the Pump to stop.
- Implanted components should not be exposed to therapeutic levels of ultrasound energy (eg, ultrasound heating and/or extracorporeal shockwave lithotripsy) used to alter or ablate tissue, as the device may inadvertently concentrate the ultrasound field and cause harm. This does not apply to diagnostic techniques such as echocardiography.
- Therapeutic ionizing radiation may damage the device and the damage may not be immediately detectable.

CAUTION !

- After the Apical Cuff has been sewn to the heart, the metal ring on the Apical Cuff should extend above the felt surface to allow proper engagement and locking with the Slide Lock of the HeartMate 3 LVAD.
- Ensure that apposition between the myocardial tissue and the cuff felt is continuous and sufficiently forceful to prevent bleeding.
- If the Slide Lock mechanism on the HeartMate 3 LVAD fails to engage, do not make further attempts to engage until retracting the Slide Lock mechanism. Evidence of the Slide Lock mechanism failing to engage will be either visual evidence of the yellow “wings,” or a tactile feel of three ridges versus one. The Slide Lock will not engage the Apical Cuff unless initially fully retracted.
- If difficulty persists when engaging the Slide Lock mechanism, the LVAD should be removed from the Apical Cuff to visualize what might be preventing the connection.
- The suture knots should not interfere with the connection.
- If a sealing agent is used on or near the Apical Cuff, it should not interfere with the slide lock mechanism.

Equipment and Supplies Required for Implant

The HeartMate 3™ Left Ventricular Assist System Implant Kit is supplied sterile and for single use only. Store components in a cool, dry place away from strong electromagnetic fields.

For a detailed product list and catalog numbers, see *HeartMate 3™ Product List* on page D-1.

CAUTION !

- Components of the HeartMate 3 Left Ventricular Assist System that are supplied sterile are intended for single use only, and should not be re-used or re-sterilized.
- Do not use sterile components if sterile packaging is compromised. Contact Abbott for Return Authorization number.

WARNING !

Moderate to severe aortic insufficiency must be corrected at time of device implant. If not addressed, the LVAD will not be able to provide the intended flow.

Abbott-Supplied Equipment

This section describes both the sterile and non-sterile components you purchased from Abbott.

Sterile Components

Sterile components of the HeartMate 3™ Left Ventricular Assist System (LVAS) Implant Kit include the following:

- Left Ventricular Assist Device (LVAD) Assembly
- 14mm Sealed Outflow Graft with Bend Relief
- Apical Cuff
- Apical Coring Knife (20mm)
- Skin Coring Punch (6mm)
- Outflow Thread Protectors (1 set)
- Modular Cable (with Modular Cable Cap)
- Tunneling Adapter
- System Controller

Non-Sterile components of LVAD system:

- Power Module (PM) with Patient Cable

WARNING !

Power Modules (PMs) are shipped to customers with the internal battery disconnected. After receiving the PM, the hospital's biomedical technician or other authorized and trained personnel must open the PM and connect its internal battery prior to using the device.

- Tablet for use with the HeartMate Touch App
- HeartMate Touch™ Wireless Adapter
- Battery Clips (set of 2) for HeartMate 14 Volt Li-Ion batteries

WARNING !

A minimum of two fully charged batteries and a pair of compatible battery clips are required at time of implant in order to power the system when transporting the patient out of the operating room.

- HeartMate batteries (set of 4) 14 Volt Li-Ion batteries (fully charged)
- 11 Volt Lithium-Ion backup battery (packaged with System Controller)
- HeartMate 3 Tunneling Lance and Handle
- User Document: *HeartMate 3 LVAS Operating Manual (IFU)*

Hospital-Supplied Equipment

This section describes the components supplied by the hospital. Each site needs to provide a HeartMate Touch™ Communication System and Power Module. (Refer to **Figure 5.1.**)

In addition, the following items are required:

- Small Drip Basin
- Sterile Graduated Pitcher (1,000 cc)
- Emesis Basins (2)
- Vent Needle
- Cardiovascular Major Surgical Set
- Heavy Non-Absorbable Ligature
- Catheter-Tipped Syringe with Sterile Normal Saline
- 12 pledgeted horizontal mattress 2-0 braided sutures

Preimplant Procedures

WARNING !

- The sealed Outflow Graft contains material of bovine origin. It should not be implanted in patients who are sensitive to such materials.
- The manufacturing process for gelatin sealed vascular grafts uses the cross-linking agent formaldehyde to achieve the graft performance. All gelatin sealed grafts are thoroughly rinsed with RO water to reduce residual formaldehyde, however residual amounts may be present in the finished graft. Formaldehyde is also found at low levels naturally in the body, some of which is derived from food. Formaldehyde is known to be mutagenic and carcinogenic. The risks of these potential harms from the product have not been established clinically.
- The sealed Outflow Graft does not require pre-clotting. Attempting to pre-clot a sealed Outflow Graft may disrupt or destroy the sealant and lead to profuse bleeding after implantation.
- Do not implant the HeartMate 3™ Left Ventricular Assist Device if it has been dropped.
- Never operate the HeartMate 3 Left Ventricular Assist Device in air, as this will immediately damage the device. Liquid must always be present in the Pump for proper function.
- Do not autoclave the Pump. This damages the Pump and Driveline.
- All entrapped air must be removed from the Pump/sealed Outflow Graft assembly blood path to minimize the risk of air embolus.

CAUTION !

- Operators must prevent blood from entering and collecting in the lumen of the conduits. Blood on the inner lumen may increase the risk of thromboembolism due to coagulum breaking free in the circulatory system. The inner lumen must, therefore, be rinsed thoroughly prior to attachment to the Left Ventricular Assist Device.

CAUTION !

- Never use tools to tighten the thread protector; securely hand tighten only. Using tools may cause damage.
- Do not allow the apical Coring Knife to involve the ventricular septum while performing left ventricle coring.
- The sealed Outflow Graft must not be kinked or positioned where it could abrade against a Pump component or body structure.
- Stretch the sealed Outflow Graft completely prior to measuring and cutting the graft to the appropriate length.
- If the Tunneling Lance is threaded, use it only with the white Tunneling Adapter. Do not use the threaded Tunneling Lance with the black Tunneling Adapter. (See **Figure 5.32.**)
- If the Tunneling Lance is non-threaded, use it only with the black Tunneling Adapter. Do not use the non-threaded Tunneling Lance with the white Tunneling Adapter. (See **Figure 5.33.**)

Preparing the Patient

Transport the patient to a cardiovascular operating room (OR). Prep and anesthetize the patient according to standard procedures.

Initializing the Power Module and HeartMate Touch™ Communication System

Prior to implant, make sure that all equipment is in good working order and ready, including what is on-hand in the operating room. This section describes how to initialize the Power Module and HeartMate Touch™ Communication System.

During implant, you must operate the HeartMate 3™ LVAD with the Power Module (PM) and HeartMate Touch Communication System as shown in **Figure 5.1**.

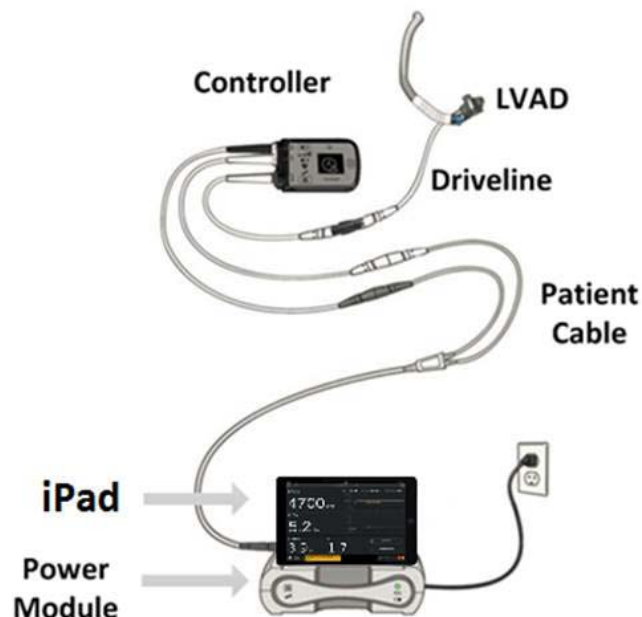

Figure 5.1 HeartMate 3™ LVAS for use with the HeartMate Touch Communication System

CAUTION !

The HeartMate Touch Communication System should be fully charged, or its AC power cord connected to an AC electrical power outlet during the surgical procedure.

WARNING !

- Connect the Power Module and any peripheral devices only to properly tested, grounded, and dedicated AC outlets.
- Do not connect the Power Module to an outlet controlled by a wall switch.

To initialize the Power Module and HeartMate Touch Communication System:

1. Ensure the Power Module is plugged into a properly testing and grounded (3 prong) AC-main outlet that is dedicated to Power Module use and is not controlled by a wall switch.
2. Ensure the Tablet for use with the HeartMate Touch App is set up and the HeartMate Touch Wireless Adapter is engaged and connected. Ensure the Power Module and HeartMate Touch power adapter are connected to power and ready for use. See *Set Up the HeartMate Touch™ Communication System* on page 4-7 for instructions.

WARNING !

- Do not use an adapter plug for ungrounded wall outlets.
- Do not use a portable multiple socket outlet (power strip), or it may cause a serious electrical shock or the Pump may stop.

3. To turn on the Tablet, press and hold the top button until the logo appears. Enter the passcode if applicable.
4. Tap **HeartMate Touch App**. Connect the Tablet for use with the HeartMate Touch App to the HeartMate Touch Wireless Adapter. See *Set Up the HeartMate Touch™ Communication System* on page 4-7 for instructions.

Unpacking

Abbott ships the implant kit in a large cardboard box. Remove all the trays from the cardboard box. Place the System Controller backup battery aside for later use.

IMPORTANT! Note that the backup battery is not sterile.

The Pump and surgical accessories are packaged in separate plastic tray containers and are packaged together within a common plastic container as shown in **Figure 5.4**. The LVAD inner tray has a snap on plastic lid cover, which in turn, is sealed by a Tyvek cover to maintain sterility.

WARNING !

- If any items are dropped, a new kit must be opened. Dropped items cannot be flash sterilized.
- Only personnel using sterile technique should touch sterile components such as the Pump, System Controller, and Modular Cable.

Note: The operating room has several sterile fields. Use care when unpacking items, as several must be placed in the sterile fields (see **Figure 5.2**).

Unpack the components in the following order:

- Left Ventricular Assist Device LVAD (Pump) and Accessories Tray
- System Controller
- Modular Cable
- Sealed Outflow Graft

Unpacking the Pump and Accessories Tray

WARNING !

Only sterilized personnel using sterile technique should make contact with sterilized implant kit accessories.

To unpack the Pump and Accessories trays:

1. Peel back and remove the cover from the main packaging tray. (See **Figure 5.2.**)



Figure 5.2 Main Packaging Tray

2. Remove the Pump and accessories trays from the main packaging tray. (see **Figure 5.3.**)



Figure 5.3 Pump and Accessories Trays

3. Peel back and remove the cover from the Pump Tray.



Figure 5.4 Pump and Accessories Tray

4. Grip the cutout in the plastic cover and separate it from the tray.
5. Remove the sterile Pump from the tray (**Figure 5.5**). Avoid touching the threaded outflow portion of the Pump or any textured surfaces.

CAUTION !

Gently guide the Pump Cable and Tunneling Adapter out of the tray as the Pump is lifted. Do not remove the Pump by the Pump Cable.



Figure 5.5 Proper Removal of Pump and Cable from the Tray

6. Move the sterile Pump to the pump preparation sterile area.
7. Inspect the quality of the white washer in the outlet.

- Maintaining strict sterile technique, screw the sterile Tunneling Adapter on to the Pump Cable connector. (See **Figure 5.6.**)



Figure 5.6 Attaching the Tunneling Adapter to the Pump Cable

- Ensure that the Tunneling Adapter is completely screwed down tight by covering the yellow line on the in-line connector. (**Figure 5.7.**)



Figure 5.7 Securing the Connection between the Tunneling Adapter and the Pump Cable Inline Connector

10. Grip the notched cutout of the Accessories Tray and peel back the lid. (See **Figure 5.8.**)



Figure 5.8 Accessories: Apical Sewing Cuff, Thread Protectors, Coring Knife, and Skin Coring Punch

11. Remove all the sterile components from the Accessories Tray and place in the sterile work area.

Unpacking the Sealed Outflow Graft

The sealed Outflow Graft comes in a box that has a foil pouch and double plastic trays with sealed covers. To unpack:

1. Open the sealed Outflow Graft box and foil pouch-containing desiccant. The foil pouch is a protective cover only and should not be introduced into the sterile field.
2. Remove the outer tray from the foil pouch. The outer tray is not sterile. Only the innermost tray may be introduced into the sterile field.
3. Peel back the cover to expose the sealed Outflow Graft. (See **Figure 5.9**).



Figure 5.9 HeartMate 3™ Sealed Graft with Bend Relief

4. Remove the sealed Outflow Graft and Bend Relief from the inner tray and move them to the sterile preparation area.

Preparing the Sealed Outflow Graft

Characteristics that identify and distinguish a HeartMate 3™ sealed outflow graft from a HeartMate II™ sealed Outflow Graft are as follows:

- The product packaging label indicates it is a HeartMate 3 sealed outflow graft.
- Blue dashed line on the bend relief.
- Purple screw ring that attaches to the Pump (the HeartMate II has a blue screw ring).

WARNING !

- The sealed Outflow Graft should not be implanted in patients who exhibit sensitivity to materials of bovine origin.
- The manufacturing process for gelatin sealed vascular grafts uses the cross-linking agent formaldehyde to achieve the graft performance. All gelatin sealed grafts are thoroughly rinsed with RO water to reduce residual formaldehyde, however residual amounts may be present in the finished graft. Formaldehyde is also found at low levels naturally in the body, some of which is derived from food. Formaldehyde is known to be mutagenic and carcinogenic. The risks of these potential harms from the product have not been established clinically.
- A sealed Outflow Graft (**Figure 5.10**) does not require pre-clotting. Attempting to pre-clot a sealed Outflow Graft may disrupt or destroy the sealant and lead to profuse bleeding after implantation.

- a. Sealed Graft
- b. Bend Relief
- c. Screw Ring

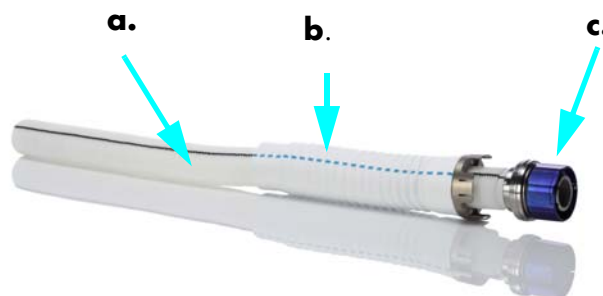

Figure 5.10 HeartMate 3™ Sealed Outflow Graft

To prepare a HeartMate 3 sealed Outflow Graft for implantation, in a sterile environment, using a strict sterile technique, complete the following procedure:

1. Remove the bend relief from the graft.
2. Examine the graft; verify that the black "O" ring and white washer are present and intact at the screw-ring end of the conduit.
3. Inspect the interior of the graft and remove any debris.
4. Attach the open thread protector.
5. Place the bend relief over the graft, with the metal end sliding toward the screw ring. The bend relief should be disengaged for the de-airing procedure.

Only the Vascular Graft is intended to be cut or clamped, not the Outflow Graft Bend Relief.

Unpacking the System Controller

The System Controller comes in a double plastic tray setup with a sealed cover. To unpack the System Controller:

1. Peel back the cover of the outer plastic tray and then peel back the lid of the inner tray.
2. Remove the inner tray from the packaging. (See **Figure 5.11**.)



Figure 5.11 Controller in Tray

3. Peel back the cover of the inner tray to expose the System Controller (see **Figure 5.12**).



Figure 5.12 System Controller

4. Remove the System Controller from the tray and move to the sterile working area. Secure the power cables so that they stay within the sterile field.

Unpacking the Modular Cable

The Modular Cable is packaged in a sealed plastic tray inside another sealed plastic tray. To unpack:

1. Open the box containing the Modular Cable and remove the plastic tray (see **Figure 5.13.**)



Figure 5.13 Modular Cable in Packaging

2. Peel back the lid of the outer plastic tray and then peel back the lid of the inner tray (see **Figure 5.14**).



Figure 5.14 Outer and Inner Plastic Trays with Lids Peeled Back from Modular Cable

3. Remove the sterile Modular Cable and the Modular Cable Cap from the packaging. This cap protects the connector from fluids and debris.

4. Install the Modular Cable Cap onto the Modular inline Connector by completing the following steps:
 - a. Insert the Modular inline Connector into the Modular Cable Cap.
 - b. Press firmly until the Modular inline Connector bottoms inside the Modular Cable Cap.
 - c. Ensure that the Modular inline Connector is fully inserted into the Modular Cable Cap.
 - d. Wrap a clean and dry sterile towel around the Modular Cable Cap and Modular inline Connector.
 - e. Move the Modular Cable to the sterile work area (**Figure 5.15.**)



Ensure the inline connector is fully inserted into the cap.

Figure 5.15 Covering the Inline Connector with the Cap

Connecting and Initializing the Sterile System Controller to Non-Sterile Equipment

This section describes how to connect and initialize the sterile System Controller.

WARNING !



- At least one System Controller power cable must be connected to a power source at all times. Disconnecting both power cables at the same time will cause the Pump to stop.
- Never disconnect the patient cable from the Power Module unless the patient first switches to battery-powered operation.

To connect and initialize the sterile System Controller:

1. Wirelessly connect the Tablet for use with the HeartMate Touch App to the HeartMate Touch™ Wireless Adapter. See *Set Up the HeartMate Touch™ Wireless Adapter* on page 4-7.
2. Pass the two System Controller power cable ends out of the sterile field and connect them to the bifurcated ends of the Power Module patient cable, white-to-white and black-to-black. Both the Power Module and System Controller will indicate a hazard alarm condition signifying that the System Controller is powered but not connected to the HeartMate 3™ LVAD. Do NOT connect the System Controller to the Pump.
3. Tap **CONTINUE** and enter a session name.

IMPORTANT! Only create names that identify the session. Do not enter any protected health information or individually identifiable health information. Follow your organization's policies, procedures, and employee training that correspond to HIPAA regulatory standards.

IMPORTANT! You should restrict the characters to a through z, 0 through 9, underscores (_), and periods (.).

4. Use the HeartMate Touch App to silence the alarm by tapping  **Silence Alarms** (see **Figure 5.16**). Do not silence the alarm signal using the System Controller.
5. Verify that a flashing communication icon  is shown in the top left corner of the HeartMate Touch App (will be displayed on all views). This icon establishes that the HeartMate Touch Communication System is properly connected to the System Controller and the correct monitoring software is running.

Note: If the communication icon is not flashing, check connections and restart the HeartMate Touch App.

6. Go to the Clinical view (tap **Menu** () > **Clinical**).

7. Tap **Settings** (⚙️) > **Controller** and verify that the time and date are correct on the HeartMate Touch App. Then use the HeartMate Touch App to set the System Controller clock. See *Controller Date & Time* on page 4-33 for instructions on setting the date and time on the HeartMate Touch App.
8. Verify that the HeartMate Touch App displays PUMP OFF and DRIVELINE DISCONNECTED alarm messages. (See **Figure 5.16**).

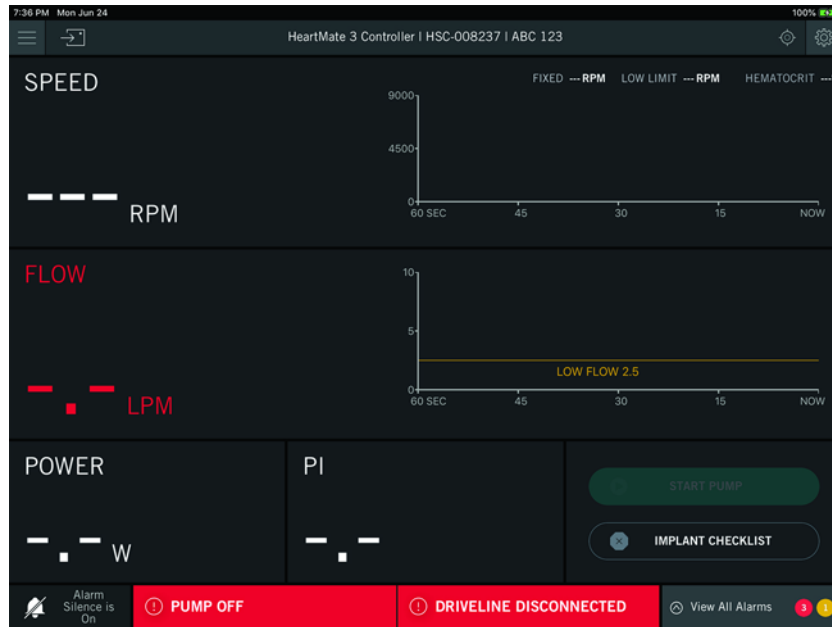

Figure 5.16 HeartMate Touch™ App When Initially Connected to the System Controller

9. Tap **View All Alarms** > **EXTENDED ALARM SILENCE** > **YES**. This action will silence all hazard and advisory alarms for four hours to ensure that they will not sound in the OR. The alarm silence indicator should display **Extended Silence is On**. The extended silence can be

canceled by pressing the Silence Alarm button on the System Controller's user interface panel or by disconnecting the HeartMate Touch Communication System from the Power Module.

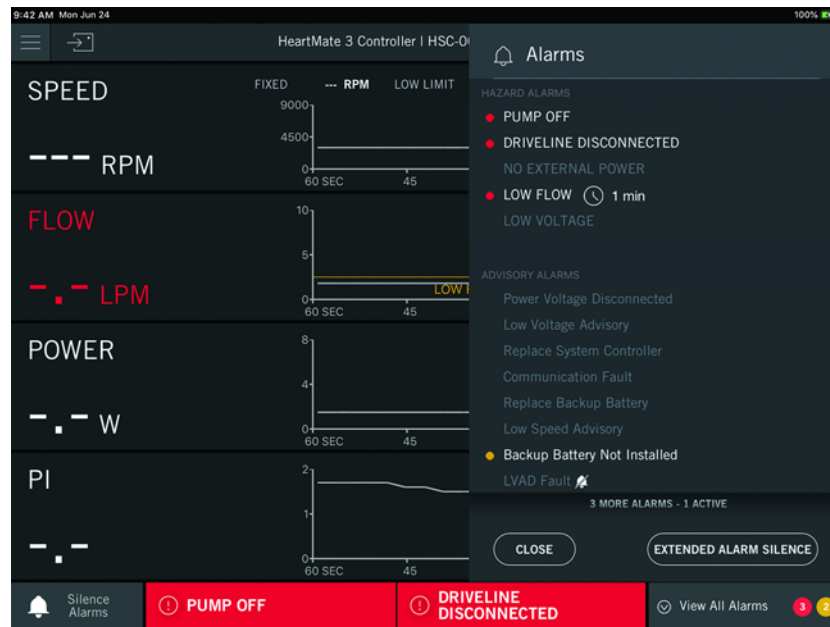

Figure 5.17 Alarms View when Initially Connected to the System Controller

10. System Controller configuration is now complete. The Driveline Disconnected alarm will remain active until the System Controller is connected to the LVAD, and the pump off alarm message will remain active until the LVAD is turned on by tapping **START PUMP** on the HeartMate Touch App.

Preparing, Running, and Priming the Pump

This section provides instructions for submerging the Pump in saline and running it for a minimum of five minutes at 3,000 rpm to verify Pump operation.

WARNING !

- Only sterile personnel should perform the following procedures.
- Never operate the HeartMate 3™ Left Ventricular Assist Device in air, as this will immediately damage the device. Liquid must always be present in the Pump for proper function.

1. Attach the Modular Cable Controller Connector to the System Controller by performing the following steps:
 - a. Rotate the Safety Lock to the open position (see **Figure 5.18.**)
 - b. Align the arrows on the Modular Cable Controller Connector and System Controller.
 - c. Insert the Modular Cable Controller Connector into the System Controller until the connector clicks and locks into place.
 - d. Gently tug on the end of the connector to ensure proper engagement.
 - e. Lock the Modular Cable connection to the System Controller by sliding the cable Safety Lock in the direction of the 'lock' symbol until the red button is no longer visible.

CAUTION !

If the Safety Lock cannot fully close to cover the red button, the connector is not fully connected.



Figure 5.18 Locking Mechanism on System Controller

2. Prepare a sterile graduated pitcher (1000 cc) with a minimum of 1 liter of sterile saline.

3. Examine the Pump Outflow connector to verify the presence of a white washer (See **Figure 5.19.**) If the white washer is missing or damaged, obtain another Pump before continuing with the following steps.



Figure 5.19 HeartMate 3™ LVAD

4. Submerge and fully cover the Pump in the saline filled graduated pitcher while taking care to exit the inline connector side of Pump Cable up and over the edge of the basin.
5. Gently tap and shake the Pump while it is submerged to release any trapped air within the Pump.
6. To make the connection between the Pump and the System Controller, you will need to remove the Tunneling Adapter and cap by completing the following steps:
 - a. If the pump cable connector and Tunneling Adapter are wet, dry the connector area with a clean and dry sterile towel. Using a clean and dry sterile towel, grip the connector area and disconnect the Tunneling Adapter, orienting the Tunneling Adapter downward. Leave the Tunneling Adapter tied to the pump cable. Visually confirm that the inside of the pump cable connector is dry. If the pump cable connector is not dry, discard the pump and obtain a new one.
 - b. Remove the towel that is wrapped around the modular cable inline connector and modular cable cap. If the modular cable and/or the modular cable cap are wet, dry them with a clean dry sterile towel. Leave the cap tethered to the modular cable. Visually confirm that the inside of the modular cable connector is dry. If the modular cable inline connector is not dry, discard the modular cable and obtain a new one.

7. Connect the sterile Pump and Modular cables by performing the following:

Note: Connecting the sterile Pump and the Modular cables makes the connection between the Pump and the System Controller.

- a. Verify the inline connectors of the Pump Cable and Modular Cable connectors are secure in the sterile area.
- b. Align the inline connection triangles on the connectors to ensure proper pin alignment.
- c. Apply firm force to engage the inline connector and rotate the locking nut in the locking direction.
- d. Push the inline Connectors firmly together.
- e. Rotate the locking nut of the inline connector to the locked position as indicated on the markings (**Figure 5.20**).

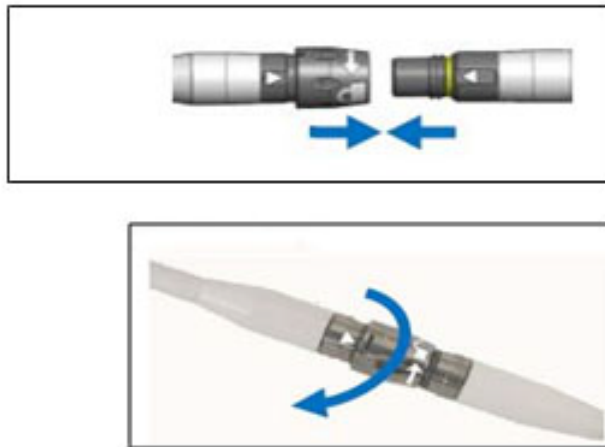

Figure 5.20 Pushing the inline Connectors Together and Rotating the Locking Nut

- f. Listen for a clicking sound as the locking nut is rotated. The clicking sound is normal.
- g. Continue to tighten until the clicking sound stops.
- h. Turn the locking nut until the yellow line on the threaded portion of the connector is no longer visible. After the inline connection is made, the Pump is electrically connected.

WARNING !

- The Modular inline Connector on the Driveline is for external to the body use only. The Modular inline Connector must not be implanted.
- Only personnel using sterile technique should touch sterile components such as the Pump, System Controller, and Modular Cable.

Note: The sterile personnel may instruct the non-sterile personnel to initiate commands on the HeartMate Touch™ App.

On the HeartMate Touch App, the Driveline Disconnected alarm should disappear and the pump speed box should now display "--" (see **Figure 5.21**).



Figure 5.21 Clinical View

8. If the speed setpoint is not 3,000 rpm, complete the following steps:
 - a. On the HeartMate Touch App, tap **Settings** (⚙️) > **Pump**. Adjust the Fixed Speed to 3,000 rpm. You will need to prime the pump.
 - b. Tap **Settings** (⚙️) > **Pump** to initiate the Pump priming operation.

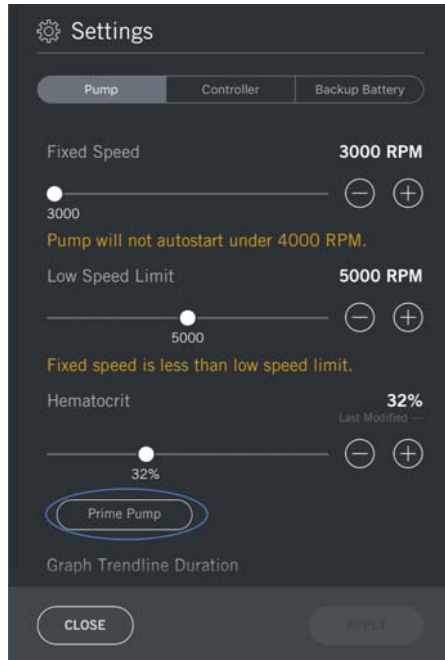

Figure 5.22 Settings > Pump

- c. Tap **Prime Pump**. A message appears (Figure 5.23). Ensure that the pump is submerged before priming.

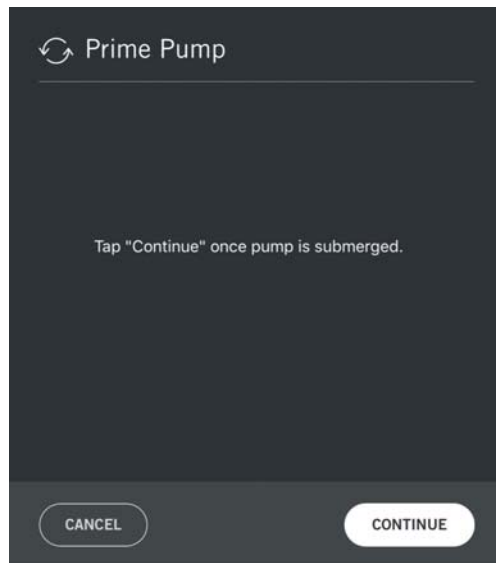

Figure 5.23 Submerge Pump Message

WARNING !

The pump should be submerged before priming.

- d. Tap **CONTINUE**. The pump may take up to 10 seconds to start.

Note: Tap **CANCEL** if you do not want to begin the priming process.

- e. Ensure the pump continues to operate. A five minute countdown timer appears.

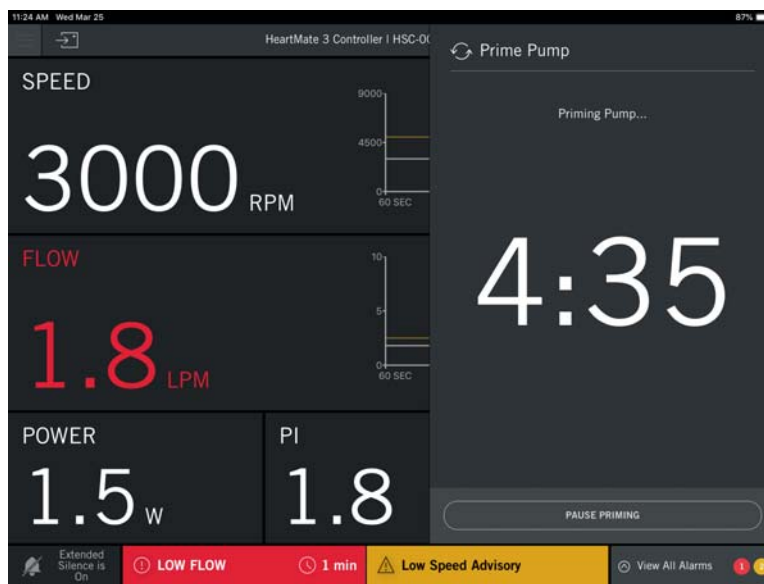

Figure 5.24 Prime Pump

Note: You can tap **PAUSE PRIMING** during this process.

If you tap **PAUSE PRIMING**, the timer will pause and the pump will stop.

If you tap **RESUME PRIMING** the process continues (pump will continue) and the timer will continue where it left off.

If you tap **CANCEL** and then confirm, the priming pump feature and the pump will stop.

- f. When the timer reaches zero the pump stops and the “Priming is complete” message appears. Tap **CONTINUE** to close the pump priming panel. The Clinical view appears.

WARNING !

If the Pump fails to operate properly, do not implant it. Utilize the back-up HeartMate 3 LVAD in its place.

9. Enter the Patient Hematocrit (**Settings** (🔧) > **Pump**). Determine the patient's hematocrit via blood analysis (in %). This analysis is required to ensure a proper flow estimation performance.
10. Disconnect the inline connector by unthreading the locking nut in the direction of the 'unlock' symbol. You will hear a clicking sound as you rotate the locking nut (this is normal). When the clicking sound has stopped, then pull connectors apart. Leave the Pump in the sterile graduate pitcher of sterile saline.
11. Maintaining strict sterile technique and using dried gloved hands, attach the sterile Tunneling Adapter to the Pump Cable connector. (see **Figure 5.25**).



Figure 5.25 Attaching the Tunneling Adapter to the Pump Cable

12. Ensure that the Tunneling Adapter is completely screwed down tight by covering the yellow line on the inline connector (**Figure 5.26**).



Figure 5.26 Securing the Connection between the Tunneling Adapter and the Pump Cable Inline Connector

13. Install the Modular Connector Cap onto the end of the Modular Cable. Wrap a clean and dry sterile towel around the Modular Connector Cap and inline connector. This Modular Connector Cap protects the connector from fluids and debris. Do not disconnect the Modular Cable from the System Controller. Ensure the cable stays sterile.
14. Secure the length of the Modular Cable (attached to the System Controller) so it does not fall out of the sterile field.
15. Leave the System Controller power cables connected to the Power Module. If the power cables are disconnected, the extended alarm silence will be reset.
16. While still in the sterile area, remove the Pump from the graduate pitcher and install the thread protector with the Luer-Lok cap on the Pump Outlet as shown in **Figure 5.27**.

CAUTION !

Do not over-tighten the thread protector and the Tunneling Adapter.

17. Open the Luer-Lok cap to allow air to escape.



Figure 5.27 Attach the Luer-Lok connector to the Pump Outlet

18. With the Inflow Cannula facing upward, fill the Pump with sterile saline through the Inflow Cannula until it flows out of the cap. Close the Luer-Lok cap.
19. Gently tap the side of the Pump and observe air bubbles rising to the surface.
20. Tap and add saline until the Pump appears full and no further air bubbles can be observed. All entrapped air must be removed from the Pump blood path in order to minimize the risk of air embolus.
21. Cut a fingertip off of a powder-less sterile glove and use it to cover the Inlet extension of the inflow.
22. Place antibiotic-soaked laps over the Pump and velour portion of the Pump Cable then set aside the Pump in a sterile, safe place. Be sure to secure the entire length of the Pump Cable so it does not fall out of the sterile field.

Preparing the Coring Knife

The Coring Knife has two protective end caps held in place by a string. Using strict sterile technique, complete the following procedure:

WARNING !

The cutting end of the Coring Knife is extremely sharp and should be handled with care to prevent injury.

1. Cut the string securing the end caps to the Coring Knife as shown in **Figure 5.28**.



Figure 5.28 Coring Knife

2. Take the Coring Knife handle and insert it through the holes in the side of the Coring Knife as shown in **Figure 5.29**. Insert the handle so it creates a "T" handle enabling handling of the tool during surgical procedure as shown in **Figure 5.30**.



Figure 5.29 Assembling Coring Knife Handle



Figure 5.30 Assembled Coring Knife

Implant Procedures

The proper orientation of the Left Ventricular Assist Device is shown in **Figure 5.31**. The Inflow Cannula is placed utilizing left ventricle (LV) apical cannulation with the Pump placed within the pericardial space between the ventricular apex and the diaphragm. An abdominal pocket is not required for implantation; therefore, entry into the abdominal cavity will not be performed. The sealed Outflow Graft attached to the ascending aorta and the Pump Cable exits the right upper quadrant of the abdomen and connects to the external equipment.

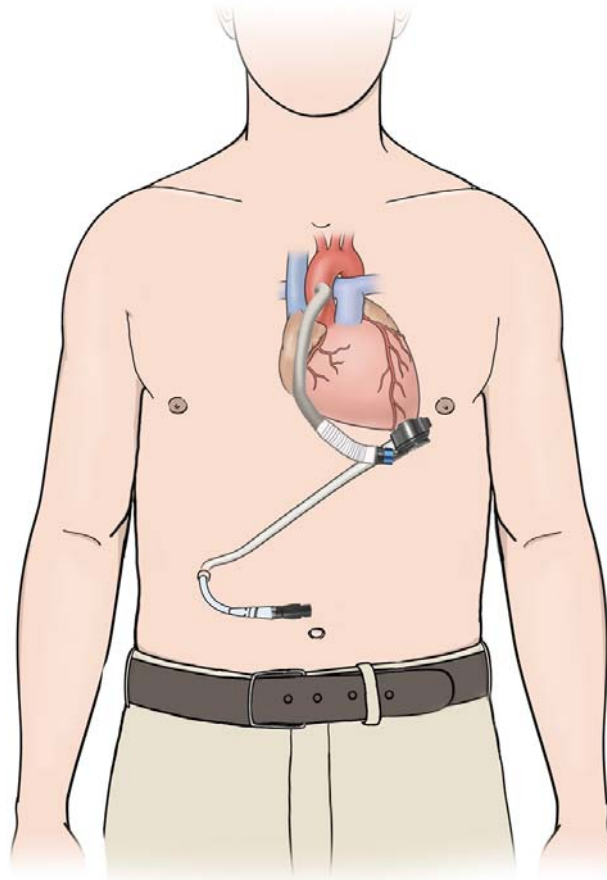



Figure 5.31 HeartMate 3™ Implantation Configuration

WARNING !

- Do not open the foil pouch until ready to use the sealed Outflow Graft. Store sealed grafts inside the foil pouch. Once removed from the pouch, the sealed Outflow Graft must be implanted within 24 hours.
- Stretch the sealed Outflow Graft completely prior to measuring and cutting the graft to the appropriate length.
- Prior to advancing the sealed Inflow Cannula into the left ventricle through the apical cuff, remove the glove tip from the inlet extension. Inspect the ventricle and remove any previously formed clots that may cause embolism or any trabeculae that may impede flow.
- Confirm that the thread protectors have been removed from the sealed Outflow Graft and the Pump prior to attempting connection.
- Maintain left atrial pressure (LAP) at greater than 10 mm Hg at all times to prevent air entrainment. The HeartMate 3™ Left Ventricular Assist Device is capable of producing negative pressure when the Pump output exceeds blood flow from the left ventricle.
- All entrapped air must be removed from the device blood-pumping chamber and conduits to reduce the risk of air embolus.
- All entrapped air must be removed from the device blood-pumping chamber and conduits prior to fully releasing the sealed Outflow Graft cross-clamp.
- At least one System Controller power cable must be connected to a power source (Power Module, Mobile Power Unit, or two HeartMate 14 Volt Lithium-Ion batteries) at all times.
- A minimum of two fully-charged batteries, a pair of compatible battery clips, and a System Controller are required at the time of implant to power the system when transporting the patient out of the OR.
- Do not use the HeartMate 3 Left Ventricular Assist Device in pregnant women or in women likely to become pregnant. A growing fetus may dislodge the Pump, which may result in device failure, catastrophic bleeding, or death. Instruct women of childbearing age to use reliable contraception if sexually active. Blood thinners have been associated with birth defects. Anticoagulation regimens are contraindicated during pregnancy.
- Do not subject patients implanted with the HeartMate 3 Left Ventricular Assist System to Magnetic Resonance Imaging (MRI)  as the device contains Ferromagnetic components. MRI can cause Pump failure or patient injury.
- Keep patients away from the RF-shielded room of MRI suites.

WARNING ! (Continued)

- Prior to implanting an implantable cardiac defibrillator or implantable pacemaker in a HeartMate+ 3 patient, the device to be implanted should be placed in close proximity to the Pump (approximately 10 cm) and the telemetry verified. If a patient receives a HeartMate 3 and has a previously implanted device that is found to be susceptible to this programming interference, Abbott recommends replacing the implantable cardiac defibrillator device with one that is not prone to programming interference.
- The HeartMate 3 pump may cause interference with implantable cardiac defibrillators (ICD). If electromagnetic interference occurs it may lead to inappropriate ICD therapy. The occurrence of electromagnetic interference with ICD sensing may require adjustment of device sensitivity and/or repositioning the lead.
- Initial weaning of cardiopulmonary bypass should ensure a minimum of two liters per minute (lpm) of blood flow to the Left Ventricular Assist Device in order to prevent air embolism. Prolonged de-airation may be due to inadequate blood supply to the Left Ventricular Assist Device or a leak in the sealed Outflow Graft or sealed Inflow Cannula.
- Patients with mitral or aortic mechanical valves may be at added risk of accumulating thrombi on the valve when supported with left ventricular assist devices.
- A sealed HeartMate 3 Outflow Graft must be used. A sealed HeartMate II™ Outflow Graft is not appropriate for use with the HeartMate 3 LVAS.
- Do not trim or cut the bend relief of the sealed Outflow Graft or a sharp edge may result. This sharp edge could damage the underlying graft material and cause blood loss.

CAUTION !

- Sharp bends, twists, or kinks in the Driveline may make it more susceptible to wear and fatigue over time.
- Do not allow the apical Coring Knife to involve the interventricular septum while performing left ventricle coring.
- The sealed Outflow Graft and Pump Cable must not be kinked or positioned where it could abrade against a Pump component, surgical element, or body structure.
- Remove all vents on the inflow side of the Left Ventricular Assist Device, including needles in the pulmonary vein, left atrium, and left ventricle prior to initiation of pumping.

CAUTION !

- Failure to connect the bend relief to the sealed Outflow Graft so that it is fully and evenly connected can allow kinking and abrasion of the graft, which may lead to serious adverse events such as low Left Ventricular Assist Device flow and/or bleeding.
- Care should be taken to ensure that the sealed Outflow Graft bend relief remains connected during sternal closure.
- Once the Left Ventricular Assist Device is activated, reduce cardiopulmonary bypass flow rapidly to provide ample blood flow to the Left Ventricular Assist Device. Whenever possible, maintain the HeartMate 3 at a pump flow greater than 3 lpm and a pump speed greater than 4,000 rpm.
- If the Tunneling Lance is threaded, use it only with the white Tunneling Adapter. Do not use the threaded Tunneling Lance with the black Tunneling Adapter. (See **Figure 5.32.**)
- If the Tunneling Lance is non-threaded, use it only with the black Tunneling Adapter. Do not use the non-threaded Tunneling Lance with the white Tunneling Adapter. (See **Figure 5.33.**)

Final Check of Prepared Equipment

Prior to implantation, confirm that:

- The bend relief is in place over the sealed graft and disengaged from the metal fitting.
- The Left Ventricular Assist Device is completely primed with Sterile Saline for Injection.
- The HeartMate 3™ Pump has been run for at least 5 minutes successfully in Sterile Saline for Injection.
- The patient's hematocrit has been entered into the HeartMate Touch™ App (once the pump and System Controller are connected to the Power Module).

Opening the Chest

A midline chest incision is made not to extend below the xiphoid process. The pericardium is opened and reflected laterally to allow exposure of the LV apex.

Creating the Driveline Exit Site

The tunnel created for the Pump Cable should be as long as possible to maximize ingrowth along the cable's polyester velour covering and to minimize the risk of exit site infection. The Pump Cable has been designed to allow for velour or silicone to cross the exit site.

FOR THIS TASK YOU NEED:

- 1 HeartMate 3™ Left Ventricular Assist Device, prepared for use
- 1 HeartMate 3 Tunneling Lance and Handle
- 1 6 mm skin coring punch

TO CREATE THE DRIVELINE EXIT SITE:

CAUTION !

The HeartMate 3 Tunneling Lance and Handle are provided non-sterile. Ensure that the Lance and handle have been cleaned, inspected, and sterilized in accordance with the provided instructions and hospital policy.

CAUTION !

If the Tunneling Lance is threaded, use it only with the white Tunneling Adapter. Do not use the threaded Tunneling Lance with the black Tunneling Adapter. (See **Figure 5.32.**)



Threaded Tunneling Lance

Figure 5.32 Threaded Tunneling Lance and Tunneling Adapter Compatibility

(The Threaded Tunneling Lance is packaged in Catalog Number 10010372GBL.)

CAUTION !

If the Tunneling Lance is non-threaded, use it only with the black Tunneling Adapter. Do not use the non-threaded Tunneling Lance with the white Tunneling Adapter. (See **Figure 5.33.**)

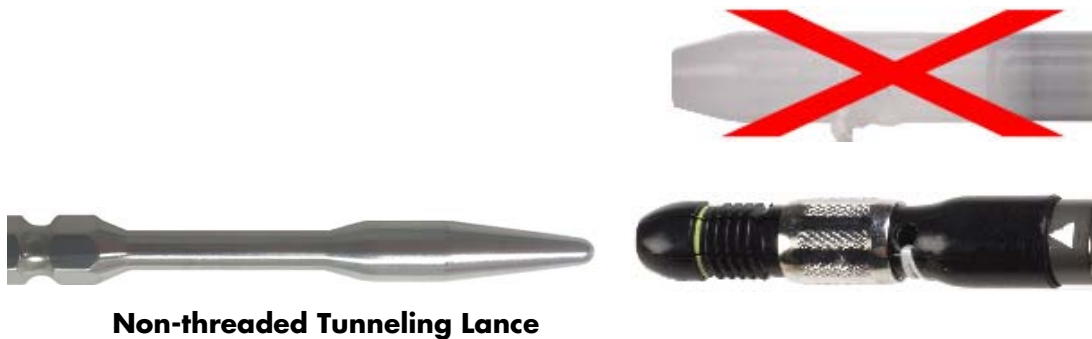

Figure 5.33 Non-threaded Tunneling Lance and Tunneling Adapter Compatibility

(The Non-threaded Tunneling Lance is packaged in Catalog Number 106533US.)

1. Place the HeartMate 3 LVAD in the chest to approximate where the device will be positioned in order to visualize the path of the Pump Cable.
2. Wipe any debris from the threads of the Tunneling Lance using a clean and dry sterile towel.
3. While keeping the Pump Cable connected to the Tunneling Adapter, rotate the Tunneling Adapter onto the Tunneling Lance without twisting the Pump Cable. Continue to rotate until it is firmly connected to the Tunneling Lance, as shown in **Figure 5.34**.



Figure 5.34 Rotating the Tunneling Adapter

4. Confirm that the Tunneling Adapter covers all of the threads of the Tunneling Lance and covers the yellow line of the Pump Cable inline connector for a secure connection as shown in **Figure 5.35**.



Figure 5.35 Securing the Connection between the Tunneling Adapter and the Tunneling Lance

5. Identify proposed exit site location (one that minimizes future Driveline interference with clothing or belts).
6. Insert the pointed tip of the Tunneling Lance into a small incision appropriately positioned on the inner abdominal wall.
7. Starting from the inferior aspect of the pocket, create a long and gently curved tunnel that passes through the right rectus abdominus and subcutaneous tissue to an exit site in the upper right quadrant.
8. Prior to exiting the dermis, place a mark at the exit site. Use the 6 mm skin coring punch supplied in the implant kit to create a circular incision at this position. Externalize the tip of the lance thru the circular incision.

9. If using the Tunneling Handle, connect the handle to the lance by retracting the handle flange and inserting the tip and hexagonal feature until captured in the handle. Carefully advance the lance in order to externalize the Pump Cable.
10. Disconnect the Tunneling Lance from the Tunneling Adapter but leave the Tunneling Adapter connected to the Pump Cable.
11. Inspect the Driveline to ascertain that it is free from any sharp bends or kinks. Consideration should also be given to the potential for sharp bends and kinks occurring postimplant with ventricular remodeling during HeartMate 3 Left Ventricular Assist System support. Make sure the Pump Cable is clear of anatomical or surgical elements that could cause wear. Consider that the exit site may also be impacted by body habitus changes after implantation.
12. The Pump Cable has been designed to allow a silicone-skin or velour-skin interface at the exit site.
13. Place the prepared Pump into the prepared space.

Attaching the Sealed Outflow Graft to the Aorta

FOR THIS TASK YOU NEED:

- 1 sealed Outflow Graft with bend relief

TO ATTACH THE SEALED OUTFLOW GRAFT:

1. Confirm that the bend relief is added to the sealed Outflow Graft prior to attaching it to the aorta with the thread protector on the graft.
2. Place Pump in the anatomical position.
3. Stretch the graft completely, measure and cut the sealed Outflow Graft to the appropriate length, and then anastomose the graft to the ascending aorta in an end-to-side fashion using 4-0 polypropylene running sutures. Make sure that the suture line is secure with no blood loss. Clamp the graft near the aorta.

Preparing the Ventricular Apex Site

FOR THIS TASK YOU NEED:

- 1 Apical Coring Knife (20 mm)
- 1 Apical Cuff

TO PREPARE THE VENTRICULAR APEX SITE:

Note: The Apical Cuff can be affixed to the Left Ventricle via two methods: Sew Then Cut or Cut Then Sew

CAUTION !

- After the Apical Cuff has been sewn to the heart, the metal ring on the Apical Cuff should extend above the felt surface to allow proper engagement and locking with the Slide Lock of the HeartMate 3™ LVAD.
- Ensure that apposition between the myocardial tissue and the cuff felt is continuous and sufficiently forceful to prevent bleeding.

SEW THEN CUT METHOD

1. Cannulate and initiate cardiopulmonary bypass.
2. Choose the coring location slightly anterior to the apex, a few centimeters lateral to the left anterior descending coronary artery.
3. Ensure that the metal skeletal structure is facing away from the myocardium, and that the black markings are visible on the Apical Cuff.

4. Complete the following steps:

- a. Target the placement of the sutures on the black circumferential line marked on the Apical Cuff (**Figure 5.36**).

This will help ensure that a hemostatic connection between the Apical Cuff and the heart tissue, for which uninterrupted opposition between the myocardial tissue and the Apical Cuff felt is required.

CAUTION !

When placing sutures into the myocardium, ensure they will not be cut by the Coring Knife.

- b. Approximately one and a half centimeters from the core, suture the sewing ring cuff with at least 12 pledgeted horizontal mattress 2-0 braided sutures almost full thickness.
- c. Apply corresponding sutures to the felt sewing cuff.



Figure 5.36 Placement of Sutures Between the Metal Ring and the Circumferential Line on the Apical Cuff

5. Ensure that the sutures do not approximate or traverse any of the metallic surfaces.
6. Place the sutures and pledgets such that the resulting Apical Cuff and surrounding tissue produces no interfering tissue that would prevent the VAD from approximating the Apical Cuff (**Figure 5.37**).

Figure 5.37 shows suturing that results in an Apical Cuff without protruding myocardial tissue, and that will allow proper engagement of the Slide Lock. Either a full backstitch or partial backstitch (one of each shown) can be considered for approximation of epicardium and felt, and hemostasis.

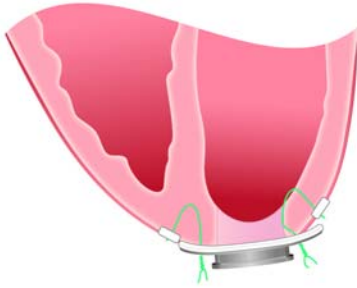

Figure 5.37 Suturing Resulting in an Apical Cuff Without Protruding Myocardial Tissue

7. Complete the following steps to gather the myocardium around the felt cuff:
 - a. Separate the sutures.
 - b. Tie the sutures tight with 6 to 7 throws on each knot.

CAUTION !

Ensure that apposition between the myocardial tissue and the cuff felt is continuous and sufficiently forceful to prevent bleeding.

8. Complete the following steps when sewing the Apical Cuff to the exterior of the heart:
 - a. Ensure that the suture knots are not interfering with the connection.
 - b. If a sealing agent is used on or near the Apical Cuff, ensure that it does not interfere with the Slide Lock mechanism.
9. Complete the following steps:
 - a. Apply the cutting edge of the coring knife to the epicardium, and maintain pressure while rotating the knife until the ventricular cavity is entered (**Figure 5.38**).
 - b. Align the orientation of the Coring Knife toward the mitral valve.
 - c. Take care to avoid orienting the inlet towards the interventricular septum.
Pump function will be compromised in the presence of inlet obstruction.



Figure 5.38 Coring Ventricular Apex

10. Complete the following steps:

- a. Remove the core and inspect the ventricular chamber for mural thrombi and crossing trabeculae.
- b. Address one or both, as needed.

CUT THEN SEW METHOD

The Apical Cuff may be sewn to the exterior of the ventricle (as described in Steps 3–8 in the Sew Then Cut Method section), after the ventriculotomy is created by advancing the Coring Knife into the heart (as described in Steps 9 and 10 in the Sew Then Cut Method section).

Inserting the Pump in the Ventricle

FOR THIS TASK YOU NEED:

1 Pump with Thread Protector Installed

TO INSERT THE PUMP IN THE VENTRICLE:

Carefully perform the following steps to ensure proper placement of the Pump and Inflow Cannula:

1. Remove glove tip.
2. Retract the Slide Lock so that it is in the fully opened position as far as it will go (**Figure 5.39**).



Figure 5.39 Retracting the Slide Lock

3. Insert the Inflow Cannula into the opening within the cuff.
4. Rotate the Pump so that the Outflow Graft is directed to the midline of the thorax and the Pump Cable is oriented toward the midline (**Figure 5.40**).

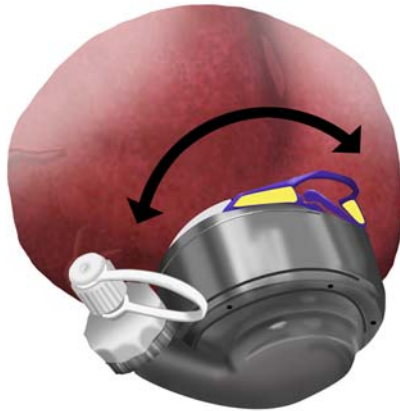

Figure 5.40 Inserting Inflow Cannula and Rotating Pump

5. When the Inflow is inserted into the ventricle, ensure that the thread protector is secure and the luer fitting is tight to prevent air entrainment.
6. Push the Slide Lock on the Pump inward to engage and lock the Pump into position (**Figure 5.41**).



Figure 5.41 Pushing the Slide Lock Inward to Engage and Lock the Pump Into Position

7. Gently pull on the Slide Lock to ensure that it is properly engaged.

8. If the Slide Lock mechanism on the HeartMate 3 LVAD fails to engage, do not make further attempts to engage until retracting the Slide Lock mechanism.

Evidence of the Slide Lock mechanism failing to engage will be either visual evidence of the yellow “wings,” or a tactile feel of three ridges versus one.

The Slide Lock will not engage the Apical Cuff unless initially fully retracted.

9. Inspect the entire circumference of the Pump-cuff junction to ensure that the LVAD is properly seated.

The Slide Lock (with the exception of the tab) will be fully inserted, and no “yellow zone” is visible.

10. If the yellow zone is visible, fully retract the Slide Lock and repeat Steps 4–8.

11. Position the heart and Pump in the position that will be expected upon chest closure.

12. If the orientation of the Pump requires adjustment, complete the following steps:

- a. Use a sterile surgical tool to unlatch the Slide Lock, if necessary.
- b. Retract the Slide Lock so that it is in the fully opened position as far as it will go.
- c. Rotate the Pump to the preferred location.
- d. Fully engage the Slide Lock.
- e. Confirm the seating, as described in Step 9.

Attaching the Sealed Outflow Graft to the Pump

FOR THIS TASK YOU NEED:

- 1 sealed Outflow Graft with bend relief (attached to the Aorta)
- 1 Pump (inserted into the Apical Cuff)

TO ATTACH THE SEALED OUTFLOW GRAFT:

1. Remove the thread protector from the Pump and the Outflow Graft. Using the Screw Ring, attach the Outflow Graft to the Pump Cover, turning the ring clockwise. You will hear a clicking sound as you tighten the Screw Ring (this is normal). Continue turning the ring clockwise until it comes to a complete stop and stops clicking. See **Figure 5.42**.

CAUTION !

To avoid damaging the assembly, do not use tools to tighten the Screw Ring.



Figure 5.42 Attach the Graft

2. Verify that the graft is not twisted or kinked by checking the position of the black line on the graft above and below the bend relief. The line should be straight.

De-Airing the Pump

When the Pump is in place and the sealed Outflow Graft anastomoses is completed, residual air must be completely evacuated from the device blood chamber prior to initiating device activation. Transesophageal echocardiography (TEE) should be utilized to monitor for air emboli. It is advisable to monitor the left atrial pressure, which should be maintained at greater than 10 mm Hg.

FOR THIS TASK YOU NEED:

- 1 HeartMate 3™ Left Ventricular Assist Device, prepared for use (see *Preparing, Running, and Priming the Pump* on page 5-25)
- 1 HeartMate Touch™ Communication System and Power Module, prepared for use (see *Set Up the HeartMate Touch™ Communication System* on page 4-7)
- 1 HeartMate Touch Wireless Adapter for connecting the Tablet for use with the HeartMate Touch App to the Power Module, through a Bluetooth® pairing.
- 1 or more clamps
- 1 vent needle

TO DE-AIR THE PUMP:

1. Cross-clamp the sealed Outflow Graft at the distal end and move the bend relief toward the aortic anastomosis.
2. Place the patient in the Trendelenburg position.
3. Position the sealed Outflow Graft in a vertical position, such that an arch forms the highest point.
4. Insert a vent needle at the highest point in the graft between the clamp and the sealed Outflow Graft connection.
5. Reduce cardiopulmonary bypass flow to allow filling of the left ventricle and Left Ventricular Assist Device by diverting at least two liters per minute (lpm) of blood to the ventricle.
6. To initiate HeartMate 3 Pump operation, you will need to connect the pump cable connector to the modular cable by completing the following steps:
 - a. Dry the pump cable connector and Tunneling Adapter with a clean and dry sterile towel. Using a clean and dry sterile towel, grip the connector area and disconnect the Tunneling Adapter, orienting the adapter downward. Leave the Tunneling Adapter tied to the pump cable. Visually confirm that the inside of the pump cable connector is dry. If the connector is not dry, discard pump and obtain a new one.
 - b. Remove the towel that is wrapped around the modular cable inline connector and modular cable cap. Visually confirm that the inside of the modular cable connector is dry. If the connector is not dry, discard the cable and obtain a new one. If the Modular Cable and/or the Modular Cable Cap are wet, use a clean dry sterile towel to dry them.

- c. Connect the inline connector by firmly pushing the connectors together. Rotate the locking nut to the locked position as indicated on the markings. You will hear a clicking sound as you tighten the locking nut (this is normal). Ensure the yellow line is fully covered for a secure connection.
7. On the HeartMate Touch App Clinical view, complete the following steps:
 - a. Verify that the PUMP OFF and LOW FLOW alarm messages appear.
 - b. Tap **Settings** (⚙️) > **Pump**.
 - c. Verify the pump has a speed setpoint of 3,000 rpm (**Figure 5.43**). If the speed setpoint is not 3,000 rpm, tap **Settings** (⚙️) > **Pump** and adjust the Fixed Speed to 3,000 rpm.

IMPORTANT! The needle vent should be placed in the sealed Outflow Graft in the highest point in the lumen (anterior side to optimize air removal).

The surgical field may be optionally flooded with sterile saline or CO₂ to further minimize the risk of air entry and possible embolization.



Figure 5.43 Clinical View — Initial Pump Startup

8. Tap **START PUMP** to initiate Pump speed at 3,000 rpm. A confirmation message appears. Tap **START PUMP** to start. Tap **CANCEL** to return to the Clinical view.

The pump may take up to 10 seconds to start. The PUMP OFF message should disappear and the Low Speed Advisory message should appear.

Figure 5.44 and **Figure 5.45** show the typical Clinical View displayed by the HeartMate Touch App during and after initial pump startup.

The Pump Flow box displays "-." when any of the following occur:

- The driveline is disconnected.
- Communication Fault.
- The estimated pump flow is outside the expected operational range (less than 4000 rpm AND a Pulse Index greater than 9.0).

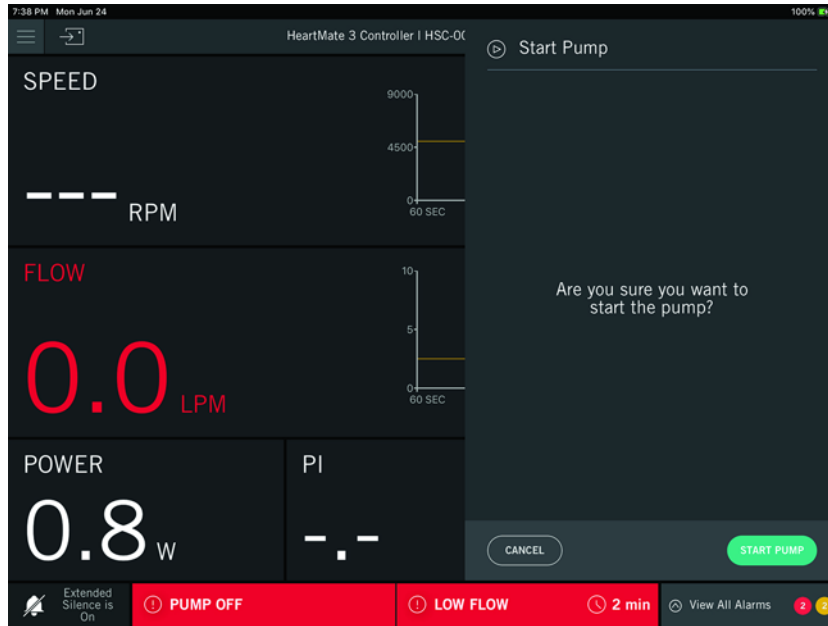

Figure 5.44 Clinical View During Initial Pump Startup (typical)

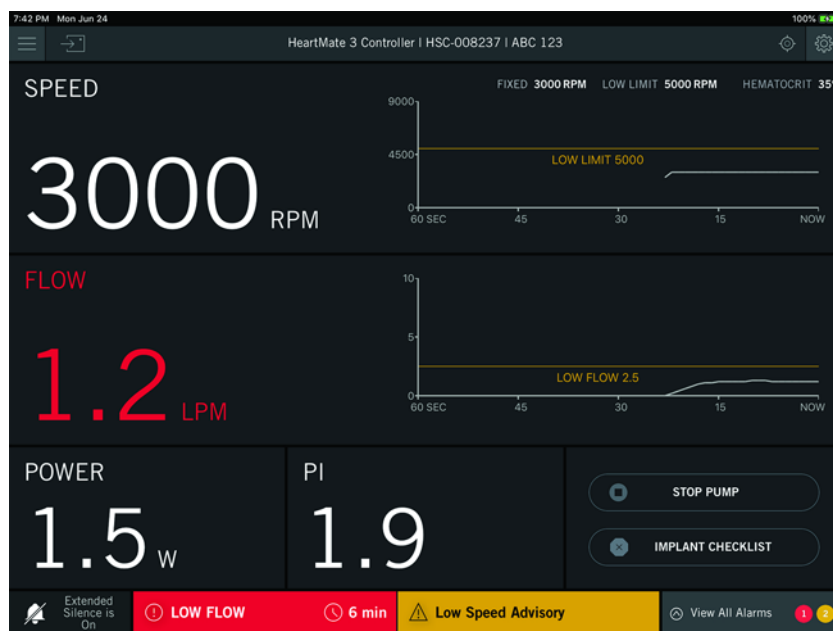

Figure 5.45 Clinical View After Initial Pump Startup (typical)

9. Watch for air being expelled through the venting needle. Throughout the de-airing process, always monitor for the presence of air in the aorta and left heart using intraoperative TEE, and keep the left heart full.
10. When de-airing is completed, partially remove the sealed Outflow Graft cross-clamp while continuing to operate the Left Ventricular Assist Device. Blood volume should be shifted from cardiopulmonary bypass to the patient to allow for adequate pump flow.
11. Remove the vent needle from the sealed Outflow Graft and repair the site only when air can no longer be observed exiting through the needle. If air persists in the Pump sealed Outflow Graft for a prolonged period (more than 5–10 minutes), rule out leaks at the sealed Inflow Cannula/Pump connection.
12. Slide the bend relief over the metal fitting of the sealed Outflow Graft toward the locking screw ring until it engages into place.

WARNING !

Failure to connect the Bend Relief so that it is fully and evenly connected can allow kinking and abrasion of the graft. This may lead to serious adverse events such as low Left Ventricular Assist Device flow and/or bleeding.

13. Visually inspect the bend relief to confirm that it is fully connected and seated to the sealed Outflow Graft (**Figure 5.46**). To confirm, try to unseat the connected bend relief from the metal fitting by gently pulling the bend relief back toward the anastomosis and then towards the pump. The bend relief should remain captured and move approximately 0.5 mm without disengaging from the graft. (**Figure 5.47**).

CAUTION !

Do not rotate/twist the sealed graft. Check the alignment of the black line on the graft to verify that the sealed graft is not twisted or kinked.

Note: The HeartMate 3 LVAD may create electromagnetic interference with ECG monitoring. Adjustment of ECG lead placement may reduce the level of interference.



Correct: Fully Connected



Incorrect: Not Fully Connected

Figure 5.46 Bend Relief Connection to the Sealed Outflow Graft (Correct and Incorrect)

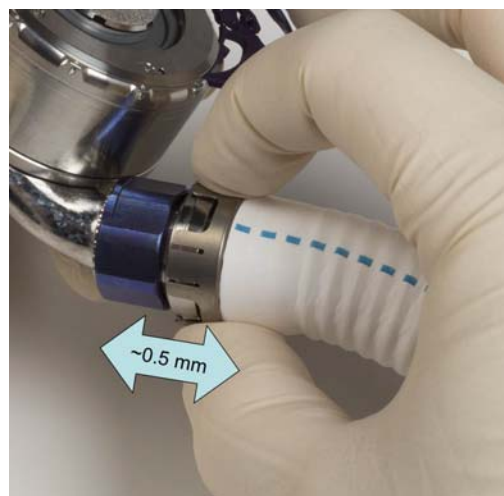



Figure 5.47 Confirm the Bend Relief Connection – Moving Back and Forth

WARNING !

Do not use an Outflow Graft Clip on a HeartMate 3 LVAD with the  logo (**Figure 5.48a**), as this HeartMate 3 LVAD has features to prevent outflow graft rotation so the Clip is not needed. Features on this HeartMate 3 LVAD may prevent proper Clip installation and attempting to use the Clip may lead to adverse events such as bleeding.

The Outflow Graft Clip should only be used on a HeartMate 3 LVAD with the  logo (**Figure 5.48b**), refer to the section, Postimplant Considerations for Clip instructions, if needed.

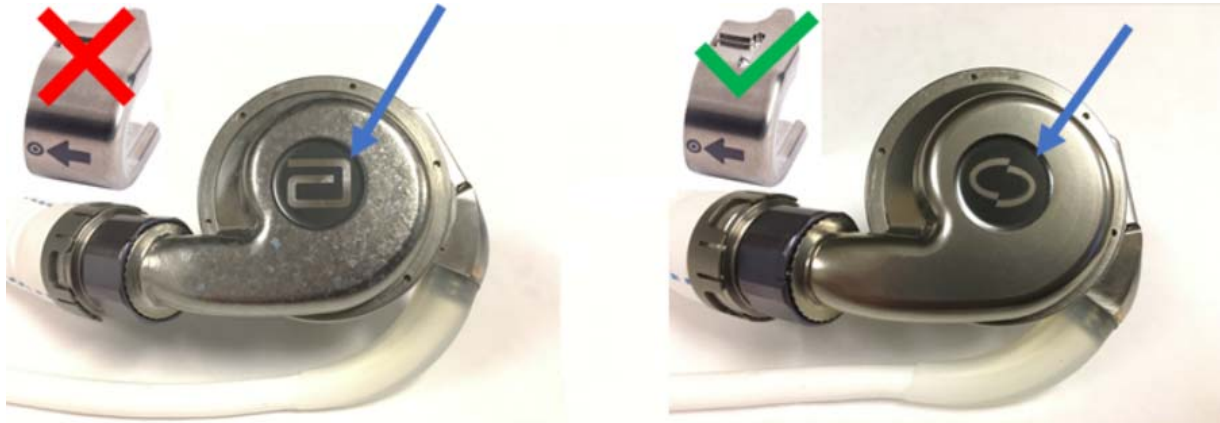





Figure 5.48a. HeartMate 3 LVAD with  logo __ **Figure 5.48b.** HeartMate 3 LVAD with  logo
Figure 5.48 Outflow Graft Clip and HeartMate 3 LVAD Logo Compatibility

14. When all air has been removed from the blood pump, it is safe to increase the pump speed (rpm). Adjust the Fixed Speed setpoint by completing the following steps:
 - a. On the HeartMate Touch App, tap **Settings** ().
 - b. Change the fixed speed by tapping **+/-** or by using the scroll bar to select the preferred pump speed setting.
 - c. After the preferred pump speed is selected, tap **APPLY** to confirm changes and send the command to the pump.
15. Terminate cardiopulmonary bypass to provide ample blood flow to the Left Ventricular Assist Device. The goal at this time is to achieve and maintain appropriate flow levels by adjusting the fixed speed of the Pump. Along with flow, the LV size, position of the septum, and aortic valve opening should be monitored to determine the appropriate fixed speed setting. The final decision is ultimately dependent on the physician's clinical judgment and will vary from patient to patient.
16. Adjust the pump speed (flow) by completing the following steps:
 - a. Adjust the fixed speed setpoint (**Settings** () > **Pump**) by moving the slider to adjust the pump fixed speed (you can also tap **-** or **+**).
 - b. Tap **APPLY** to confirm changes.

The actual flow increase for a given change in speed is dependent on many factors and could vary significantly.

Pump flow is dependent upon the pressure difference across the Pump, aortic pressure at the outflow minus left ventricular pressure at the inflow, and will fluctuate throughout the cardiac cycle. **Figure 5.49** illustrates that, when left ventricular pressure equals aortic pressure, a Pump running at 5,000 rpm will result in a 6.5 lpm pump flow rate. At an aortic pressure of 80 mmHg and a left ventricular pressure of 10 mmHg, a pressure difference across the Pump of 80-10=70 mmHg, a Pump running

at the same speed would flow 3 lpm. By increasing the speed to 6,000 rpm, the same 70 mmHg pressure difference across the Pump would result in a 6 lpm pump flow. This relationship demonstrates that the flow generated by the Pump is directly related to the pressure difference across the Pump and heavily dependent upon left ventricular pressure.

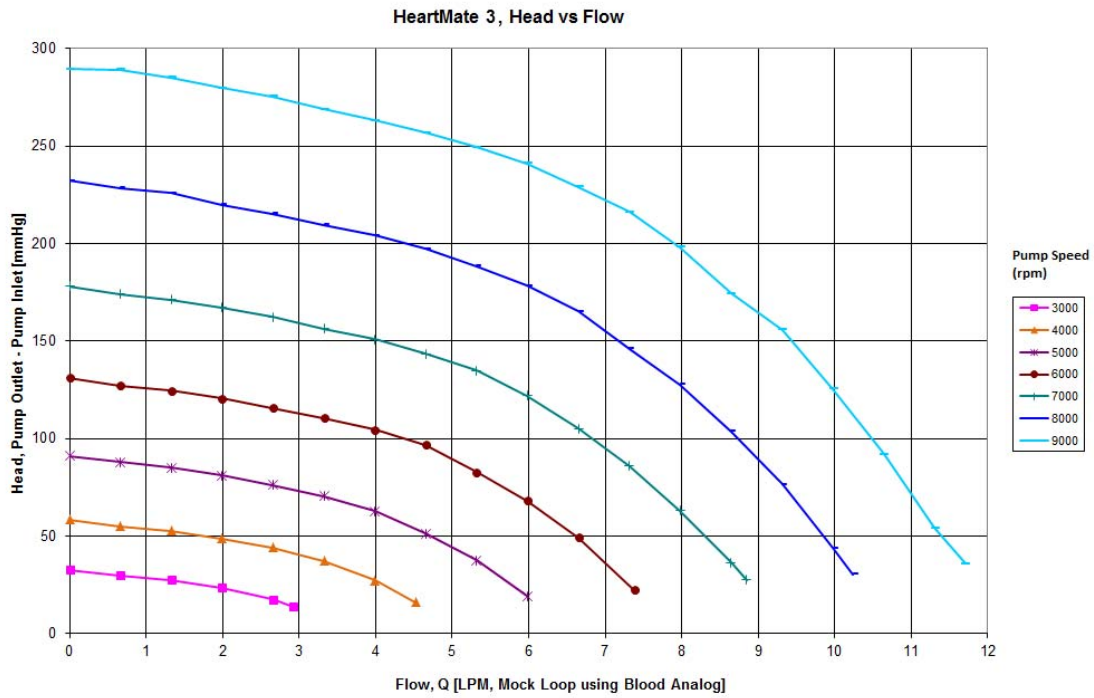

Figure 5.49 Typical HeartMate 3 Flow Characteristics

IMPORTANT! The Pump will start when the System Controller is connected to a Driveline and a power source if one of the following is true:

- The fixed speed is set to 4,000 rpm or higher.

OR

- The System Controller's backup battery is installed and any button is pushed on the System Controller.

IMPORTANT! The Pump can only be started from the HeartMate Touch App Clinical view screen if both the following conditions are present:

- The fixed speed setting is below 4,000 rpm.

AND

- The System Controller's backup battery is not installed.

IMPORTANT! Auscultation over the Pump pocket is recommended to verify the Pump is running.

Securing the Pump and Connections

CAUTION !

Care should be taken to ensure that the sealed Outflow Graft bend relief remains connected during sternal closure.

Once the flow through the blood Pump is satisfactory, ensure that the sealed outflow connections are dry and secure. Obtain hemostasis and close all wounds in the standard fashion. Prior to leaving the OR, immobilize the Driveline and Controller.

CAUTION !

The use of electrocautery devices may temporarily interfere with HeartMate 3™ Pump operation. When electrocautery has been discontinued, there is no interference with Pump operation.

Postimplant Procedures

Transferring the Patient Out of the Operating Room

1. Cancel the extended alarm silence by pressing the Silence Alarm button on the System Controller's user interface panel to cancel the extended alarm silence.
2. Go to the HeartMate Touch App Alarm Status and verify the Extended Alarm Silence is off.
3. Tap **IMPLANT CHECKLIST**. Review the checklist and ensure that all settings are correct and that no additional modifications are needed (**Figure 5.50**).

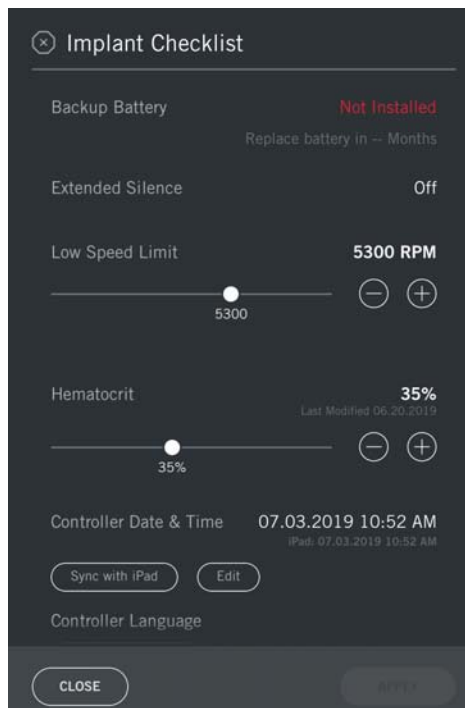



Figure 5.50 Review Implant Checklist Settings

4. Switch the HeartMate 3™ Left Ventricular Assist System from the Power Module to battery power (see *Switching from the Power Module to Battery-Powered Operation* on page 3-66).
5. Tuck the batteries securely beside the patient so that the System Controller, power cables, and Driveline are not subjected to strain during patient transport.
6. After the patient reaches the ICU, return to Power Module power and verify that the alarm silence is off.
 - a. Return to Power Module power.
7. As a reminder that the backup battery needs to be installed, a yellow wrench flashes and a graphic is displayed on the System Controller. Refer to *System Controller Backup Battery Not Installed Alarm* on page 7-22.

8. The backup System Controller needs to have the 11 Volt Lithium-Ion backup battery installed. See *Configuring the Backup System Controller* on page 2-47.

IMPORTANT! It is recommended that patient specific hemodynamics continue to be monitored during transport to the ICU. HeartMate 3 Pump parameters can be visualized by pressing the display button () on the System Controller's user interface. A cart containing the Power Module and HeartMate Touch Communication System can closely follow the patient and should be re-attached when the patient arrives at his or her destination.

Installing the Backup Battery in the System Controller

After the sterile field has been broken, proceed with installing the System Controller backup battery. As an additional measure, a plastic tab is attached to the System Controller to indicate that backup battery installation needs to occur.

WARNING !

- Do not use damaged, defective, or expired batteries. Using a damaged, defective, or expired battery may reduce operating time during a power-loss emergency or cause the Pump to stop.
- Do not open, crush, heat above 104°F (40°C), or incinerate batteries because of the risk of fire and burns. Follow manufacturer's instructions.

CAUTION !

- Charging of the 11 Volt Lithium-Ion backup battery inside the System Controller occurs only when the battery has been installed in a System Controller. After the 11 Volt Lithium-Ion backup battery is installed, a full charge occurs within 3 hours.
- If an 11 Volt Lithium-Ion backup battery leaks, do not touch the leaking fluid. If the fluid touches your skin or eyes, wash the affected area with plenty of water and seek medical advice.
- To prevent deterioration or damage to an 11 Volt Lithium-Ion backup battery:
 - Store within approved temperatures: 59°F to 77°F (15°C to 25°C).
 - Do not use in temperatures that are below 32°F (0°C) or above 104°F (40°C), or the battery may fail suddenly.
 - Do not dismantle, open, or shred.
 - Do not drop or hit against hard objects or each other.
 - Do not leave or store in extremely hot or cold temperatures (eg, in automobiles or automobile trunks), or battery life will be shortened.
 - Do not store in direct sunlight.
 - Do not expose to heat or fire.
 - Do not short circuit a battery or store it haphazardly in a box or drawer where it may short circuit or be short circuited by contact with metal objects.
 - Do not remove a battery from its original packaging until required for use.

CAUTION ! (Continued)

- Dispose of or recycle an expired battery in accordance with local, state, and federal regulations. Malfunction of the 11 Volt Lithium-Ion backup battery may cause the System Controller to become excessively hot. If this occurs, switch to the backup System Controller.

FOR THIS TASK YOU NEED:

- 1 11 Volt Lithium-Ion backup battery (included with System Controller)
- 1 lever to remove the screw cover of the battery compartment (included with 11 Volt Lithium-Ion backup battery)
- 1 screwdriver to loosen the four battery cover screws (included with 11 Volt Lithium-Ion backup battery)
- 1 spare screw cover (included with 11 Volt Lithium-Ion backup battery)

TO INSTALL THE BACKUP BATTERY IN THE SYSTEM CONTROLLER:

1. Use the lever to lift up the screw cover (**Figure 5.51**).



Figure 5.51 Use the Lever to Lift up the Cover

2. Use the screwdriver to loosen the four captive screws on the battery compartment cover (**Figure 5.52**).



Figure 5.52 Loosen the Screws

3. Lift off the battery compartment cover.
4. Remove the plastic advisory “install backup battery” tab.
5. Align the arrow on the ribbon cable with the arrow on the backup battery and then insert the cable into the battery socket (**Figure 5.53**):



Figure 5.53 Align the Arrow on the Cable with the Arrow on the Battery

6. Confirm that the 11 Volt Lithium-Ion backup battery is properly connected by verifying that the backup battery installation graphic no longer appears on the System Controller.

7. Place the backup battery inside the battery compartment (**Figure 5.54**).



Figure 5.54 Place the Battery Inside the Compartment

8. Place the cover over the battery compartment.
9. Use the screwdriver to tighten the four screws. Do not overtighten the screws.
10. Replace the screw cover.
11. Install the backup battery in the patient's backup System Controller (by following steps 1-10)



IMPORTANT! Be aware that installing an 11 Volt Lithium-Ion backup battery may prompt a Controller Clock Not Set advisory alarm on the HeartMate Touch™ App. Refer to *Controller Clock Not Set - HeartMate Touch App* on page 7-28. To resolve the advisory, use the HeartMate Touch App to reset the System Controller clock. Refer to *Controller Date & Time* on page 4-33. Be sure the HeartMate Touch App clock is correct before relying on it.

Device Tracking & Reporting Requirements

The HeartMate 3™ Left Ventricular Assist System is considered a life-sustaining medical device and must be tracked per foreign regulatory agency regulations. Compliance is mandatory. Accordingly, all device-tracking paperwork shipped with the device must be completed and promptly returned to Abbott. In addition, any device malfunctions must be reported to Abbott by the implanting center.

Postimplant Considerations

HeartMate 3 Outflow Graft Clip

Prior versions of the HeartMate 3 LVAD will have the  logo instead of the  logo (**Figure 5.55**).

In the event of a re-operation on a patient who has a HeartMate 3 LVAD with the  logo and who needs a Clip, use the following instructions.

WARNING !

Do not use an Outflow Graft Clip on a HeartMate 3 LVAD with the  logo (**Figure 5.55a**), as this HeartMate 3 LVAD has features to prevent outflow graft rotation so the Clip is not needed. Features on this HeartMate 3 LVAD may prevent proper Clip installation and attempting to use the Clip may lead to adverse events such as bleeding.

The Outflow Graft Clip should only be used on a HeartMate 3 LVAD with the  logo (**Figure 5.55b**).

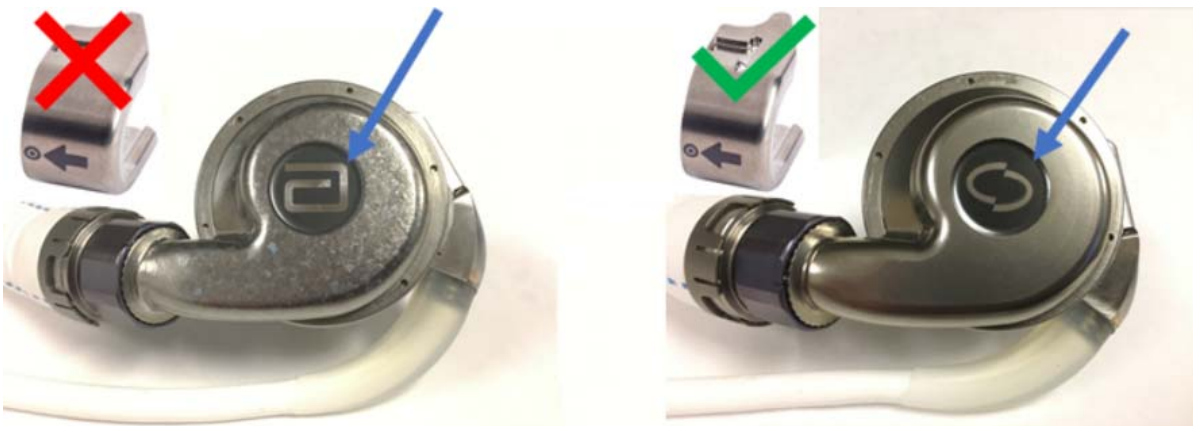



Figure 5.55a. HeartMate 3 LVAD with  logo ____ **Figure 5.55b.** HeartMate 3 LVAD with  logo

Figure 5.55 Outflow Graft Clip and HeartMate 3 LVAD Logo Compatibility

HeartMate 3 Outflow Graft Clip instructions for a HeartMate 3 LVAD with the logo

WARNING !

Attach the Outflow Graft Clip to prevent post-operative Outflow Graft twisting. Outflow Graft twisting may lead to serious adverse events such as graft occlusion, thrombosis, and/or death.

1. Attach the Outflow Graft Clip (see **Figure 5.56**) to the Outflow by taking the following actions:



Figure 5.56 The Outflow Graft Clip

- a. Place the Clip over the Screw Ring, as shown in **Figure 5.57a**, with the arrow on the Clip pointing to the Outflow. Do not push the Clip on at this time.
- b. Rotate the Clip in both directions to see its full range of rotation. The Clip and Outflow will rotate together if the Clip has been placed properly. Position the Clip in the middle of its full range of rotation, as shown in **Figure 5.57b**.
- c. Press the dot on the Clip and push until the Clip is fully seated (see **Figure 5.57c**).



Figure 5.57a

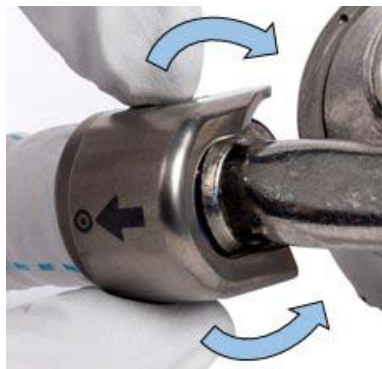

Figure 5.57b



Figure 5.57c

Figure 5.57 Attaching the Outflow Graft Clip

WARNING !

Failure to install the Outflow Graft Clip so that it is flush with the Bend Relief can allow graft twisting or abrasion. This may lead to serious adverse events such as bleeding, graft occlusion, thrombosis, and/or death.

2. Confirm that the Outflow Graft Clip is fully seated by ensuring that the labeled side of the Clip is flush with the Bend Relief, as shown in **Figure 5.58**. If needed, continue to rotate the Clip in both directions while pushing until it is fully seated.

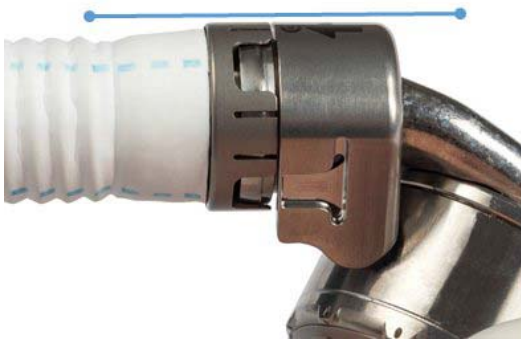

Correct: Outflow Graft Clip flush with Bend Relief

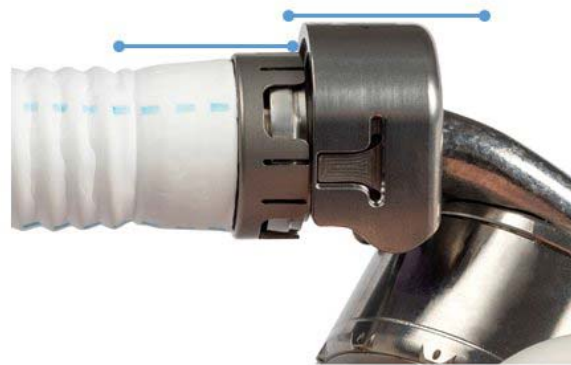

Incorrect: Outflow Graft Clip not flush with Bend Relief

Figure 5.58 Outflow Graft Clip Seating (Correct and Incorrect)

3. If you need to remove the Outflow Graft Clip, place your index and middle fingers on each side of the Clip and your thumb on the Bend Relief next to the clip (see **Figure 5.59**). Push the back sides of the Clip with your fingers and guide it straight off with your thumb.

Note: The Clip may become stuck if it is not pushed straight off. If the Clip becomes stuck, straighten it and continue to push.



Figure 5.59 Removing the Outflow Graft Clip

Device Explant

Explanting the Left Ventricular Assist Device

WARNING !

There is a risk of embolism at the Left Ventricular Assist Device explant or reoperation if manipulation of the Pump or Outflow Graft is performed prior to initiation of cardiopulmonary bypass and stoppage of device pumping.

CAUTION !

The Driveline at explant is not sterile, and care must be taken to avoid contamination of the sterile field. Sterile glove fingertips can be attached to the ends of the Driveline after it is cut to minimize the risk of contact with the sterile field.

FOR THIS TASK YOU NEED:

- 1 Cardiovascular major surgical set
- 1 HeartMate explant kit

TO EXPLANT THE LEFT VENTRICULAR ASSIST DEVICE:

1. Expose the device and carefully dissect it free.
2. Place the patient on cardiopulmonary bypass and establish flow. Disconnect power from the System Controller, and then disconnect the inline connection to stop pumping.
3. Cross-clamp the sealed Outflow Graft just distal to the bend relief and divide the graft.
4. Expose the slide lock mechanism and pull it radially to disengage the Pump from the apical cuff. Disengage the Pump from the ventricle.
5. Repair or plug the ventricle as necessary.
6. Dissect the Pump Cable between the device body and the abdominal wall. Cut the Pump Cable and then remove the externalized portion.
7. Remove the device from the chest pocket, and remove the remaining portion of the Pump Cable from the inside-out by careful dissection. Close the site in standard fashion.
8. Remove the sealed Outflow Graft remnant from the aorta and repair the anastomotic site.
9. If returning the device to Abbott for disposal, use the HeartMate Explant Kit.

PATIENT CARE AND MANAGEMENT

This section describes postoperative patient care.

Postoperative Patient Care - - - - -	6-2
Ongoing Patient Assessment and Care - - - - -	6-6
Important Clinical Considerations for HeartMate 3™ Patients - - -	6-9
Using the Shower Bag - - - - -	6-13
Wearing and Carrying System Components - - - - -	6-26
Preparing for Sleep - - - - -	6-63
Ongoing System Assessment and Care- - - - -	6-64
Educating and Training Patients, Families, and Caregivers- - - -	6-67

Postoperative Patient Care

Proper care of a patient who is supported by the HeartMate 3™ Left Ventricular Assist System requires a thorough understanding of the system operation and patient condition.

WARNING !

- There is risk of embolism at pump explant or reoperation if manipulation of the pump or conduit is performed prior to the initiation of cardiopulmonary bypass and stoppage of Left Ventricular Assist Device pumping.
- If the Left Ventricular Assist Device stops operating and blood is stagnant in the pump and conduits for more than a few minutes (depending on the anticoagulation status of the patient), there is a risk of stroke or thromboembolism should the pump be restarted.
- If the Left Ventricular Assist Device stops operating, counsel the patient to seek immediate medical attention to treat retrograde flow within the pump. Treatment measures may include heparinization, standard interventions for acutely decompensated congestive heart failure, and surgical exploration.
- Before using any HeartMate™ power accessories (Power Module, Mobile Power Unit, Battery Charger, or HeartMate 14 Volt Lithium-Ion batteries), all users (including clinicians, patients, and caregivers) must be trained on their use.
- Certain parts of the HeartMate 3 Left Ventricular Assist System are not compatible with other HeartMate systems (such as the HeartMate II™ Left Ventricular Assist System). Only use HeartMate 3 parts with the HeartMate 3 system.
- If the Pump loses external power, it may stop. If the Pump stops, connect to external power immediately. The HeartMate 3 Pump will not re-start unless external power is applied to the System Controller.
- Do not allow patients to swim or take tub baths while implanted with the Left Ventricular Assist Device. Patient immersion in water or liquid may cause the pump to stop.
- Do not allow HeartMate 3 patients to shower without a doctor's permission. Patients may be allowed to shower, but only after sufficient postoperative healing and only with a doctor's permission. If a patient is approved for showering, he or she must always use the Shower Bag for every shower. The Shower Bag protects external system components from water and moisture. If external system components have contact with water or moisture, the patient may receive a serious electric shock or the pump may stop.
- Keep the Power Module and the Mobile Power Unit dry and away from water or liquid. If the Power Module or the Mobile Power Unit comes into contact with water or liquid, either may fail to operate properly or cause a serious electrical shock.

WARNING ! (Continued)

- Never submerge the Driveline, Modular Connector, System Controller, or any external system components (such as the Power Module, the Mobile Power Unit, batteries, power cables, or battery clips) in water or liquid. Submersion in water or liquid may cause the Left Ventricular Assist Device to stop.
- A backup System Controller and charged batteries must remain with the patient at all times for use in an emergency. Patient and caregiver training must address this crucial requirement.
- High levels of static electricity may damage and/or interfere with the electrical parts of the system disrupt HeartMate Touch communication and cause the Left Ventricular Assist Device to stop. In the hospital environment, maintaining a relative humidity level of at least 20% is acceptable. The risk for electrostatic discharge (ESD) events is increased below 20% relative humidity. Avoid activities that may cause static electricity and discharge any buildup by touching a metal surface before handling LVAS components.
- Patients should be using battery power when performing activities that can generate static electricity, such as:
 - Folding or changing bedsheets
 - Taking laundry out of a dryer
 - Touching the screens of older TVs or computers (LCD and LED screens are okay).
- Do not use the HeartMate 3 Left Ventricular Assist Device in pregnant women or in women likely to become pregnant. A growing fetus may dislodge the pump, which may result in device failure, catastrophic bleeding, or death. Instruct women of childbearing age to use reliable contraception if sexually active. Blood thinners have been associated with birth defects. Anticoagulation regimens are contraindicated during pregnancy.
- Fluctuations and disturbances in the AC mains may interfere with the system and disrupt HeartMate Touch communication.
- Do not subject patients implanted with the HeartMate 3 Left Ventricular Assist System to Magnetic Resonance Imaging (MRI)  as the device contains Ferromagnetic components. MRI can cause pump failure or patient injury.
- Keep patients away from the RF-shielded room of MRI suites.
- Therapeutic radiation, such as tissue heating therapy using Radio Frequency (RF) energy sources, may damage the device, and damage may not be immediately detectable.
- The patient must always connect to the Power Module or Mobile Power Unit for sleeping, or when there is a chance of sleep. A sleeping patient may not hear the System Controller alarms.

WARNING ! (Continued)

- There may be risks associated with performing external chest compression, in the event of cardiac arrest, due to the location of the Outflow Graft and the presence of ventricular apical anastomosis. Performing external chest compression may result in damage to the Outflow Graft or the dislodgement of the Left Ventricular Assist Device inflow tract.
- Cardiac massage should only be performed by a skilled surgeon, under direct vision in patients who have had recent (ie, prior to mediastinal healing) device implantation.
- If external defibrillation becomes necessary, do not disconnect the System Controller from the Driveline prior to delivering the shock.
- If open chest defibrillation is required, it is advised that the HeartMate 3 Left Ventricular Assist System be disconnected prior to delivering the shock.
- For international travel, the patient must use a Abbott power cord that is compatible with the local voltage and that meets applicable national plug, rated voltage, rated current, and safety agency marks and specifications for the Mobile Power Unit and Battery Charger. Other power cords must not be used. Contact Abbott for a power cord, if needed. See Abbott contact information on the *Back Cover* of this manual.
- If traveling by aircraft, the patient should be instructed to bring sufficient battery power to power the system until the destination is reached. Neither the Mobile Power Unit nor the Battery Charger should be used on aircraft.
- Only connect authorized devices to USB ports and to the Tablet Lightning connector. The connection of unauthorized devices may result in device malfunction.

CAUTION !

- Right heart failure can occur following implantation of the pump. Right ventricular dysfunction, especially when combined with elevated pulmonary vascular resistance, may limit the effectiveness of the Left Ventricular Assist System due to reduced filling of the pump.
- Do not try to fix any of the equipment yourself. If HeartMate 3 equipment needs service, contact the appropriate personnel trained by Abbott.
- Notify appropriate personnel if there is a change in how the pump works, sounds, or feels.
- Counsel the patient to avoid contact sports and jumping activities while implanted with the pump. Contact sports or jumping can cause bleeding or damage the pump.
- The Driveline exit site must be dressed prior to applying Stabilization.
- To achieve the desired outcome, stabilization should be applied in the operating room, post implant.

CAUTION ! (Continued)

- Keep the Driveline exit site as clean and dry as possible.
- To avoid pulling on or moving the Driveline at the exit site, the Driveline must be stabilized at all times. Pulling on or moving the Driveline can keep the exit site from healing or damage an already healed exit site. Exit site trauma or tissue damage can increase the patient's risk of getting a serious infection. Emphasize to the patient and/or family member or caregiver the importance of not pulling on or moving the Driveline.
- Do not twist, kink, or sharply bend the Driveline, System Controller power cables, the Power Module patient cable, or the Mobile Power Unit patient cable, which may cause damage to the wires inside, even if external damage is not visible. Damage to the Driveline or cables could cause the Left Ventricular Assist Device to stop. If the Driveline or cables become twisted, kinked, or bent, carefully unravel and straighten.
- Carefully wash hands every time before and after changing the Driveline exit site bandages, or whenever the Driveline exit site is touched or handled.
- Do not place objects other than the HeartMate 3 system components into the wearable accessories. Placing objects other than HeartMate 3 components into a wearable accessory may damage the wearable accessory.
- During showers, use care to keep the exit site as clean and dry as possible. Also avoid pulling on or moving the Driveline during a shower. Position the Shower Bag so that it will not pull on or move the Driveline.
- Some radio devices such as Citizens Band (CB) radios, hand-held walkie-talkies, cordless phones and radio-controlled toys operating near 27 MHz or 40 MHz may cause interference with the HeartMate 3 LVAS during use. Advise patients to avoid using such devices and to move away from suspected radio devices when possible.

Ongoing Patient Assessment and Care

Patient Assessment

HeartMate 3™ patient assessment may include, but is not limited to, assessment of the following:

- Pump function
- Pump speed, flow, motor power, pulse index (PI), mode of operation
- Driveline is securely connected to the System Controller and the System Controller Driveline Connector Safety Lock is in the locked position
- The Modular connector is properly connected and locked
- Exit site status, immobilization of Driveline
- Vital signs, peripheral circulation
- Mental status, level of consciousness
- 12 lead EKG
- Echocardiogram

Potential Risks and Adverse Events

See *Adverse Events* on page 1-8.

Potential Late Postimplant Complications

- Hypovolemia
- Arrhythmia
- Thromboembolism
- Infection
- Psychosocial issues
- Neurological dysfunction

Caring for the Driveline Exit Site

Currently, no clinical trials delineate the best regimen for care of the Driveline exit site. Physician judgment and experience may vary. Nevertheless, the following points should be considered:

- A driveline management system, supplied by the implanting center, should be used at all times. The driveline management system should consist of a dressing and stabilizer.
- The risk of systemic infection may also be reduced by withdrawing all intravascular lines as soon as is practical.
- Parenteral treatment with antibiotics and surgical drainage has, on occasion, eradicated infection. However, infections may persist and can result in septicemia and death.
- Fungal infection resulting from organisms such as *Candida albicans* may be associated with vegetative growth on the pump. Persistent systemic fungal infection, refractory to antimicrobial treatment, may necessitate pump replacement or removal.
- Systemic prophylaxis with antifungal agents, such as fluconazole, is reported to have met with moderate success in preventing fungal infection. However, no clinical trials have been conducted to verify the efficacy of antifungal prophylaxis.

Controlling Infection

Infection among implantable Left Ventricular Assist Device patients is common, especially in patients with multisystem organ failure who require prolonged stays in the ICU. Infection rates can be minimized, however, by applying the following approaches to patient management:

- Strict adherence to sterile technique during exit site care.
- Remove all intravascular lines as soon as practical to reduce the risk of systemic infection.
- Administer antibiotic prophylaxis in the postoperative period and for suspected or confirmed infections, and antibiotics for surgical drainage, as indicated, in patients with evidence of pump pocket infection.
- Adhere to strict blood glucose control.
- Initiate nutritional support to correct nutritional deficits.

Measuring Blood Pressure

Automatic blood pressure monitors may not be accurate. Manual auscultation with a Doppler is recommended. In circumstances where the flow is pulseless, invasive blood pressure monitoring (arterial line) may be required.

Blood Pressure Management

Post-implantation hypertension may be treated at the discretion of the attending physician. Any therapy that consistently maintains mean arterial blood pressure less than 90 mm Hg should be considered adequate.

Anticoagulation

TO TREAT FOR ANTICOAGULATION:

1. Prior to leaving the OR, completely reverse the anticoagulation.
2. Optional: Postimplantation, as early as possible, administer 10% LMW dextran at 25 ml/hr. (This step is optional until the benefit of dextran administration is further delineated).
3. Begin IV heparin after 12–24 hours or when chest tube drainage is less than 50 ml/hr over a 2–3 hour period:
 - Initially titrate to a PTT of 45–50 for 24 hours (1.2–1.4 times control).
 - After 24 hours, increase heparin and titrate to PTT 50–60 (1.4–1.7 times control).
 - After another 24 hours, increase heparin and titrate to PTT 55–65 (1.5–1.8 times control).
4. On postoperative day 2–3, initiate aspirin 81–100 mg QD.
5. On postoperative day 3–5, once there is no evidence of bleeding and the chest tubes have been removed, begin warfarin (overlapping with the heparin). Discontinue heparin after obtaining an acceptable, stable INR. The INR should be maintained in the range of 2.0–3.0.
6. Maintain the patient throughout support on aspirin and warfarin.

Conditions that May Require Possible Modification to Anticoagulation

Consider the need for the following modifications to anticoagulation:

1. Sustained low pump flow states (< 3.0 lpm):
Consider increasing anticoagulation to upper limits of normal.
2. Risk of bleeding:
Consider initiating antiplatelet medications and decreasing heparin/warfarin (INR 1.7–2.3). Antiplatelet effect should be confirmed with lab studies (eg, TEG).

Important Clinical Considerations for HeartMate 3™ Patients

Magnetic Resonance Imaging (MRI)

Use of diagnostic MRI  is contraindicated in any patient with an implanted HeartMate 3™ Left Ventricular Assist Device. The presence of ferromagnetic parts within the pump makes exposure to strong electromagnetic fields a risk factor for acute pump failure. Keep patients away from the RF-shielded room of MRI suites.

External Chest Compressions

There may be risks associated with performing external chest compressions in the event of cardiac arrest, due to the location of the Outflow Graft and the presence of ventricular apical anastomosis. External chest compressions may damage the Outflow Graft or dislodge the Left Ventricular Assist Device inflow tract.

Cardiac massage under direct vision, performed by a skilled surgeon, may be effective in patients who have had recent pump implantation (prior to mediastinal healing).

Defibrillation

WARNING !

- If open chest defibrillation is required, be sure to disconnect the HeartMate 3™ Left Ventricular Assist System prior to delivering the shock.
- If external defibrillation becomes necessary, do not disconnect the System Controller from the Driveline prior to delivering the shock.

Blood Leak Diagnosis

A blood leak from any implanted component of the system is typically identified through one of the following symptoms:

- Unexplained internal bleeding (beyond the perioperative period following implant), possibly with painful distension of the abdomen or tamponade.
- Blood draining from the Driveline exit site.
- Evidence of decreased hemoglobin/hematocrit.

These symptoms may also occur due to bleeding from native tissue.

Right Heart Failure

Some patients suddenly develop right ventricular failure during or shortly after pump implantation. The onset of right ventricular dysfunction in patients is often accompanied by the inability of the Left Ventricular Assist Device to fill, and drastically reduced flow rates. Limited filling is further exacerbated in the presence of right heart failure with an elevated transpulmonary pressure gradient or high pulmonary vascular resistance.

Treatment for patients in right heart failure typically consists of inotropes to augment right ventricular contractility, fluid management, hyperventilation, and pharmacologic modulation of pulmonary vascular resistance. As a last resort, a right ventricular assist device may be employed.

Electrostatic Discharge

Electrostatic discharge (ESD) is the release of static electricity when two objects come into contact. Maintaining a relative humidity level of at least 20% is acceptable. The risk for electrostatic discharge (ESD) events is increased below 20% relative humidity. High levels of static electricity may damage and/or interfere with the electrical parts of the system, disrupt HeartMate Touch communication, and cause the Left Ventricular Assist Device to stop. Using battery power can reduce high levels of static electricity. When not sleeping or relaxing, the patient should use battery power instead of the Mobile Power Unit to power the system.

High levels of static electricity can occur while:

- Folding or changing bedsheets
- Taking laundry out of a dryer
- Dragging feet on a carpet

- Touching the screens of older TVs or computer (LCD and LED screens are okay)

Advise the patient to:

- Use battery power when possible to help reduce system damage from static electricity.
- Reduce static electricity with products, such as:
 - A humidifier to add moisture to the air
 - Dryer sheets and fabric softeners in clothes and bedsheets
 - Anti-static spray on carpets and other materials
 - Skin moisturizer on your skin
 - Cotton fabric clothing and bedsheets
- Static electricity is more common when the air is dry. Cold weather and home heating systems can make air drier. A humidifier can make air less dry and reduce static electricity.
- Fabrics like wool, silk, and synthetic materials can build up static electricity. Patients should use cotton fabrics where possible.

Implantable Defibrillators or Pacemakers

WARNING !

- Prior to implanting an implantable cardiac defibrillator (ICD) or implantable pacemaker (IPM) in a HeartMate 3™ patient, the ICD or IPM device to be implanted should be placed in close proximity to the pump (approximately 10 cm) and the telemetry verified. If a patient receives a HeartMate 3 pump and has a previously-implanted device that is found to be susceptible to electromagnetic interference, which could affect programming, Abbott recommends replacing the ICD or IPM device with one that is not prone to programming interference.
- The HeartMate 3 pump may cause interference with implantable cardiac defibrillators (ICD). If electromagnetic interference occurs it may lead to inappropriate ICD therapy. The occurrence of electromagnetic interference with ICD sensing may require adjustment of device sensitivity and/or repositioning the lead.

Using the Shower Bag

Although the external components of the HeartMate 3™ Left Ventricular Assist System are moisture-resistant (including a properly connected Driveline Modular inline connection), they are not waterproof. Take care to protect external system components from water or moisture—outside in heavy rain or snow, and always for every shower. If the external system components have contact with water or moisture, the patient may receive a serious electric shock or the pump may stop.

When taking a shower, the patient must shield all external components from water by placing them into the water-resistant Shower Bag. This includes protecting the System Controller, System Controller power cables, Driveline, and two HeartMate™ 14 Volt Lithium-Ion batteries with attached battery clips. The Shower Bag must be used for every shower (**Figure 6.1**).



Figure 6.1 Shower Bag

The Shower Bag features a translucent top panel that allows a patient to view the System Controller's user interface while showering. The Driveline and System Controller power cables exit the Shower Bag through double zippers along the side. The Shower Bag has an adjustable shoulder strap for optimal positioning to reduce pulling on the Driveline exit site. The Shower Bag also incorporates two loops and a belt. It can be worn around the waist to further secure the bag to the patient's body. Two belt loops, one on each side of the bag, allow the bag and belt to be worn on either the patient's right or left side.

Figure 6.2 shows the Shower Bag in use.

IMPORTANT! **Figure 6.2** shows an uncovered Driveline exit site. Keep the exit site as clean and dry as possible.

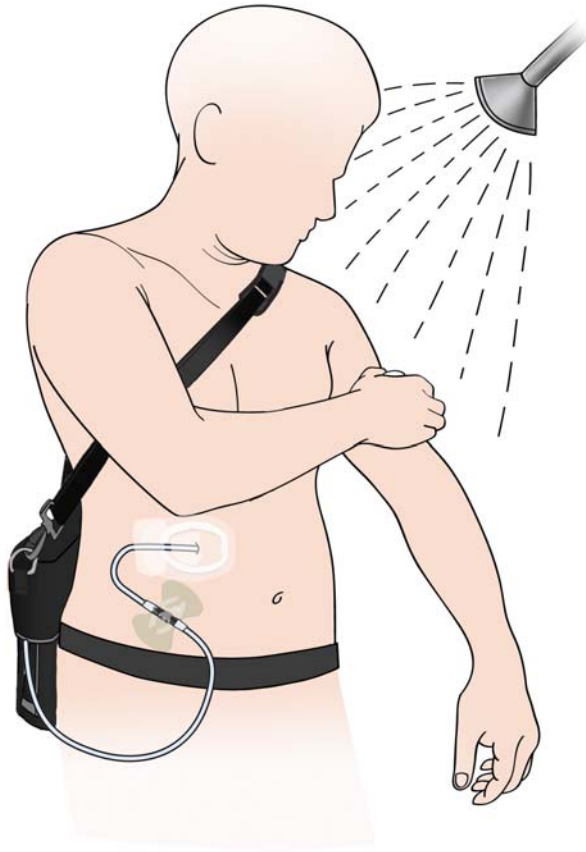

Figure 6.2 Shower Bag in Use

WARNING !

- Do not allow patients to shower without a doctor's permission. HeartMate 3 patients may be allowed to shower, but only after sufficient postoperative healing, and only with a doctor's permission.
- Do not allow patients to swim or take tub baths while implanted with the pump. Patient immersion in water will cause the pump to stop.
- Never expose the System Controller or batteries to water. The System Controller must be kept dry at all times.
- Do not submerge the Shower Bag in water.
- Patients should not shower while connected to the Power Module or the Mobile Power Unit. Use the Shower Bag only while on battery power.

CAUTION !

- To avoid pulling on or moving the Driveline at the exit site, the patient must stabilize their Driveline at all times. Pulling on or moving the Driveline can keep the exit site from healing or damage an already healed exit site. Exit site trauma or tissue damage can increase the patient's risk of getting a serious infection. Emphasize to the patient and/or family member or caregiver the importance of not pulling on or moving the Driveline.
- Do not twist, kink, or sharply bend the Driveline, the System Controller power cables, the Power Module patient cable, or the Mobile Power Unit patient cable which may cause damage to the wires inside, even if external damage is not visible. Damage to the Driveline or cables could cause the Left Ventricular Assist Device to stop. If the Driveline or cables become twisted, kinked, or bent, carefully unravel and straighten.
- Keep the exit site as clean and dry as possible.
- Carefully wash hands every time before and after changing the Driveline exit site bandages, or whenever the Driveline exit site is touched or handled.
- Do not place objects other than HeartMate 3 equipment in the wearable accessories. Placing objects other than HeartMate 3 equipment in a wearable accessory may damage the accessory.

Assembling the Shower Bag

FOR THIS TASK YOU NEED:

- 1 Shower Bag
- 1 Shoulder Bag shoulder strap
- 1 Shower Bag clip-style belt

TO ASSEMBLE THE SHOWER BAG:

1. Clip the shoulder strap to the Shower Bag using the two rings located on the top of the bag (**Figure 6.3**).



Figure 6.3 Attach the Shoulder Strap

2. To attach the clip-style belt, slide the belt through the loop on the side of the bag that will be against the patient's body (**Figure 6.4**). The Shower Bag can be worn on a patient's left or right side depending on the belt loop chosen.



Figure 6.4 Attach the Optional Belt

3. Adjust the shoulder strap so the Shower Bag fits the patient without pulling on or moving the Drive-line. Tighten or lengthen the straps until they are secure but still comfortable.

Putting On the Shower Bag

FOR THIS TASK YOU NEED:

- 1 assembled Shower Bag that is clean and dry
- 1 running System Controller on battery power

TO PUT ON THE SHOWER BAG:

1. Gather equipment; place within easy reach.
2. Make sure that the System Controller power cables and Driveline are not twisted (**Figure 6.5**).



Figure 6.5 Make Sure the Power Cables and Driveline are Not Twisted

3. Unclip the top of the Shower Bag by squeezing the clip prongs together and pulling the slide out of the buckle (**Figure 6.6**).



Figure 6.6 Squeeze the Clip Prongs Together and Slide Out the Buckle

4. Pull back the lid to reveal the double zipper (**Figure 6.7**).



Figure 6.7 Pull Back the Lid

5. Unzip and open the cover of the water-resistant enclosure.
6. Place the batteries, battery clips, and attached power cables into the Shower Bag (**Figure 6.8**).



Figure 6.8 Place the Batteries and Battery Clips Into the Bag

IMPORTANT! When putting the System Controller into the pocket, the end without the cable goes in first and the user interface should be facing up.

7. Slide the System Controller into the pocket on the inside cover of the bag, cable-free end first and with the user interface facing up (**Figure 6.9**).



Figure 6.9 Slide Controller Into Pocket

8. Prepare to close the cover by positioning the power cables inside the water-resistant enclosure (**Figure 6.10**).



Figure 6.10 Position the Power Cables Inside the Bag

9. Close and zip the cover. Make sure the System Controller power cables are inside the bag, and the Driveline exits through the protective red tabs (**Figure 6.11**).



Figure 6.11 Close and Zip the Cover

10. Close the lid over the zippered enclosure, carefully positioning the Driveline down the side of the bag (**Figure 6.12**).



Figure 6.12 The Driveline Exiting a Closed Shower Bag

11. Snap the clip into the buckle to secure the lid into place (**Figure 6.13**).



Figure 6.13 Snap the Clip into the Buckle to Secure the Lid

12. Use the Shower Bag strap to hang the Shower Bag over the patient's head and shoulder, so the Shower Bag hangs at his or her side.
13. Clip the belt around the patient's waist. The belt secures the Shower Bag and prevents it from dropping if it slips from the patient's shoulder. It also keeps the Shower Bag from swinging away from the patient's body if he or she bends over.
14. Adjust the shoulder strap so that the Shower Bag does not pull on the Driveline exit site.

Taking Off the Shower Bag

FOR THIS TASK YOU NEED:

- 1 Shower Bag that is loaded with batteries and running System Controller
- 1 large, clean, dry towel to dry the patient's body
- 1 small, clean, dry towel to dry the Shower Bag
- 4"X4" sterile gauze bandages to dry the exit site
- 1 or more sterile bandages to dress the exit site
- Wearable accessories to hold or carry the System Controller, batteries, and battery clips after showering

TO TAKE OFF AND DRY THE SHOWER BAG:

1. Unclip the belt from the patient's waist.
2. Carefully lift and remove the Shower Bag shoulder strap from around the patient's neck.
3. Place the Shower Bag on a stable surface.

CAUTION !

Do not move or pull on the Driveline exit site. Do not kink or sharply bend the Driveline.

4. Use a clean towel to dry the patient's body, excluding the area around the Driveline exit site.
5. Use a sterile 4"X4" gauze bandage to dry the Driveline exit site.
6. Apply a sterile dressing to the exit site, using an sterile technique (see *Caring for the Driveline Exit Site* on page 6-7).
7. Use a clean, dry towel to dry the Shower Bag's exterior and strap.
8. Open the Shower Bag using the clip and buckle for the lid, and the left and right zippers for the top.
9. Remove all equipment from the Shower Bag enclosure; place the equipment in a clean, dry location.
10. Transfer system components to a wearable accessory such as the holster vest, Consolidated Bag, belt attachment, or System Controller Neck Strap (see *Wearing and Carrying System Components* on page 6-26).
11. Allow the Shower Bag to drip dry completely before using it again (see *Cleaning HeartMate™ Wear and Carry Accessories* on page 8-9).

Caring for the Shower Bag

Always hang the Shower Bag and allow it to air dry. Make sure the Shower Bag is completely dry before using it for another shower. See *Cleaning and Maintenance* on page 8-4 for complete instructions on caring for all wearable accessories, including the Shower Bag.

WARNING !

The Left Ventricular Assist Device will stop if the Driveline is disconnected from the System Controller. If the Driveline is disconnected, reconnect it as quickly as possible to restart the Pump. If the System Controller does not work, replace it with a backup System Controller that is programmed with patient-specific settings.

IMPORTANT! Maintain the backup System Controller and spare batteries within the recommended environmental conditions. Refer to *Acceptable Operating Conditions* on page 2-6.

Showering

If the patient obtains doctor approval to shower, these instructions must be used each time.

Keeping your Driveline Exit Site Dry

It is important to keep the Driveline exit site dry while showering. This helps prevent infection and helps extend the use of the driveline management system. When applied correctly, covering the driveline management system with a moisture barrier consisting of a sheet of multi-purpose sealing wrap, sealed with adhesive tape on the edges, should keep moisture away.

Warnings and Precautions

WARNING !

The HeartMate 3™ System Components must be kept dry. Never expose the System Controller, Batteries, Power Module, or Mobile Power Unit to water. If these system components get wet, your pump may stop. Never take tub baths or go swimming while implanted with the pump. The HeartMate™ GoGear™ Shower Bag must be used while showering to keep the System Controller and Batteries dry.

CAUTION !

- Do not take a shower until your doctor says you can.
- Refer to the *HeartMate 3 Left Ventricular Assist System Patient Handbook* for detailed instructions and information on system function and maintenance.
- The Moisture Barrier is not a replacement for the driveline management system. It will only be used to keep the driveline management system dry during a shower.
- Apply the Moisture Barrier to clean dry skin. Do not use lotion or cream before applying.
- Do not lift or attempt to reposition the Moisture Barrier after it is placed.
- Once applied, the Moisture Barrier should only be used one time.

Applying the Moisture Barrier

1. Make a sheet of multi-purpose sealing wrap large enough to completely cover the driveline management system with at least six inches on all sides.
2. Center sheet of multi-purpose sealing wrap over the driveline management system and stick to skin (see **Figure 6.14**).

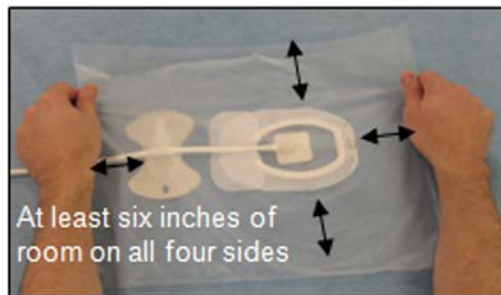

Figure 6.14 Multi-Purpose Sealing Wrap Centered Over the Driveline Management System

- a. Rub the sheet of multi-purpose sealing wrap into place with fingers so that it is smooth to the skin with no gaps.
 - b. If you have difficulties, ask your caregiver or spouse for help.
3. Seal around the edges of the sheet of multi-purpose sealing wrap with the tape (see **Figure 6.15**).
 - a. Apply the tape to all four edges of the sheet of multi-purpose sealing wrap so that there are no gaps.
 - b. Rub the tape into place with fingers so that it is smooth on the skin.
 - c. Check all edges and make sure the sheet is completely stuck to the skin with no gaps.

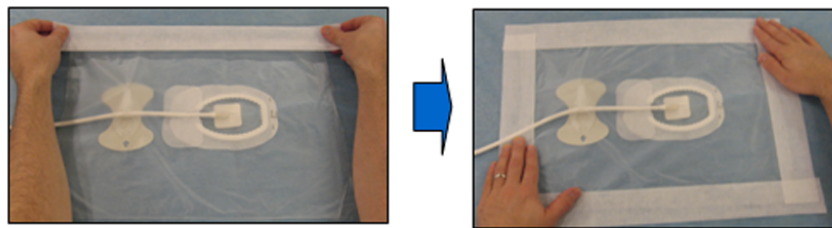

Figure 6.15 Seal Around the Edges of the Multi-Purpose Sealing Wrap Sheet

Removing After Showering

1. Towel dry body and the outside of the multi-purpose sealing wrap.

2. Gently peel away the multi-purpose sealing wrap and tape from the skin (see **Figure 6.16**).
 - a. As you remove, be careful to not disturb the driveline management system.

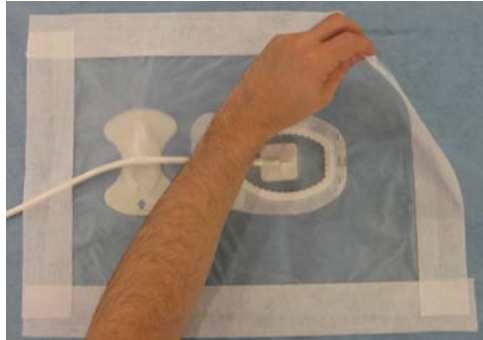

Figure 6.16 Multi-Purpose Sealing Wrap and Tape Gently Peel Away From Skin

3. If the driveline management system gets wet, change it as instructed in the previous sections.

Wearing and Carrying System Components

Various wearable accessories are available to comfortably and securely hold or carry the external system components, such as the System Controller, System Controller power cables, Driveline, batteries, and battery clips. The accessories are designed to allow patients to be active. See **Figure 6.17**.



Figure 6.17 Wearable Accessories to Hold or Carry External System Components

The wear and carry accessories are described in **Table 6.1**.

Wear and Carry Accessory	Use
System Controller Neck Strap	Worn around the neck or across the body; holds the System Controller when connected to the Power Module, the Mobile Power Unit, or during battery-powered operation.
Belt Attachment	Worn around the waist, on a belt; holds the System Controller when connected to the Power Module, the Mobile Power Unit, or during battery-powered operation.
Protection Bag	Stores and protects the backup System Controller.
Travel Bag	Worn on a shoulder. Stores the Protection Bag and a spare set of batteries.
Consolidated Bag	Worn on a shoulder and stabilized around the waist; used to carry the System Controller and 2 batteries/battery clips together in a single bag during battery-powered operation. For more information, see <i>Using the Consolidated Bag</i> on page 6-37.
Battery Holster	Worn around the shoulders and under the arms; holds the System Controller and 2 batteries/battery clips during battery-powered operation. Designed to distribute equipment weight across the shoulders and back. Comes in one size, but is adjustable to fit most.
Holster Vest	Worn around the shoulders and under the arms; holds the System Controller and 2 batteries/battery clips during battery-powered operation. Designed to distribute equipment weight across the shoulders and back. Includes a chest strap and works with or without the belt attachment. Comes in 3 sizes (small, medium, and large).

Table 6.1 Wear and Carry Accessories

Using wearable accessories, patients can stand, sit, walk, crouch, bend over, reach, turn, and lean. Common activities may include, but are not limited to: exercising, dressing, traveling, playing with children, gardening, hiking, cooking, and dancing. The patient should consult with his or her doctor about daily activities and any changes in activity level or routine.

Using the System Controller Neck Strap

The System Controller Neck Strap (**Figure 6.18**) can be worn around the neck or across the body. It attaches to the System Controller with two small straps.

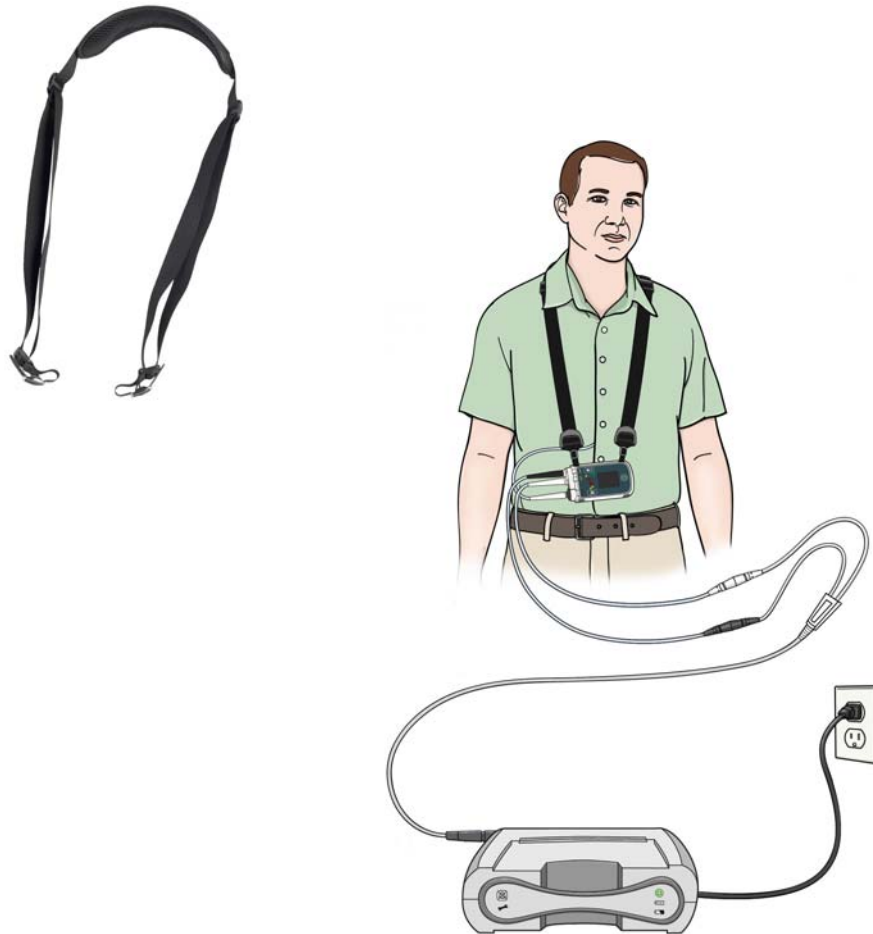

Figure 6.18 Wearing the System Controller Neck Strap

The System Controller has an attachment point built into each corner of the System Controller casing (**Figure 6.19**). Use two attachment points to suspend the System Controller, either vertically or horizontally (**Figure 6.20**).



Figure 6.19 Attachment Points on the System Controller



Figure 6.20 System Controller Suspended on System Controller Neck Strap Horizontally (left) and Vertically (right)

FOR THIS TASK YOU NEED:

- 1 running System Controller on Power Module or Mobile Power Unit power
- 1 System Controller Neck Strap

TO ATTACH AND WEAR THE SYSTEM CONTROLLER NECK STRAP:

1. Gather equipment; place within easy reach.
2. Place the System Controller on a flat, stable surface.
3. Make sure the System Controller power cables and Driveline are not twisted (**Figure 6.21**).



Figure 6.21 Make Sure the Power Cables and Driveline are Not Twisted

4. Choose two attachment points on the System Controller, for either vertical or horizontal wearing of the Neck Strap.
5. Slide the rubber strap on the Neck Strap through an attachment point on the System Controller (**Figure 6.22**).



Figure 6.22 Slide the Rubber Strap Through the Attachment Point

6. To buckle the strap, thread the rubber strap through the metal buckle on the Neck Strap. Make sure the metal prong on the buckle goes through the hole in the strap (**Figure 6.23**).



Figure 6.23 Buckle the Strap

7. Hold the System Controller in one hand and give the Neck Strap a tug with the other hand. This will help ensure that the buckle is securely connected to the System Controller (**Figure 6.24**).



Figure 6.24 Tug on the Strap

8. Repeat Step 5 through Step 7 to attach the second Neck Strap to another attachment point on the System Controller.
9. Place the Neck Strap around the patient's neck so that the System Controller is located either on the patient's chest or on the left or right side of the patient. Adjust the length of the Neck Strap as needed.

TO TAKE OFF THE SYSTEM CONTROLLER NECK STRAP:

1. Carefully remove the Neck Strap and System Controller from around the patient's neck and place them on a stable surface.
2. Unbuckle the two straps and remove the Neck Strap from the System Controller.

Using the Belt Attachment

The belt attachment accessory (**Figure 6.25**) is similar to accessories that are used to wear or carry a cell phone. The belt attachment can be attached to the patient's own belt or attached to the provided nylon clip belt.



Figure 6.25 Wearing the Belt Attachment

FOR THIS TASK YOU NEED:

- 1 running System Controller on Power Module or Mobile Power Unit power
- 1 belt attachment
- 1 personal belt (up to 2" wide) or 1 provided nylon clip belt

TO PUT ON THE BELT ATTACHMENT:

1. Gather equipment; place within easy reach.
2. Make sure the System Controller power cables and Driveline are not twisted (**Figure 6.26**).



Figure 6.26 Make Sure the Power Cables and Driveline are Not Twisted

3. Slide either the patient's belt or the provided nylon belt through the loop on the back of the belt attachment (**Figure 6.27**).



Figure 6.27 Slide the Belt Through the Loop on the Belt Attachment

4. Unclip the two-banded strap on the belt attachment.

5. Slide the System Controller, cable-free end first, into the belt attachment with the display screen facing out (**Figure 6.28**).



Figure 6.28 Slide the System Controller Into the Belt Attachment

6. Place the two-banded strap over the System Controller and between the white System Controller power cable connector and the Driveline connector (**Figure 6.29**).



Figure 6.29 Place the Strap Between the Connectors

7. Clip the two-banded strap into place (**Figure 6.30**). Make sure both prongs are fully engaged in the clip.



Figure 6.30 Clip the Strap Into Place

8. Fasten the belt and belt attachment around the patient's waist. Adjust and tighten the belt as necessary.

TO TAKE OFF THE BELT ATTACHMENT:

1. Hold the belt attachment and System Controller securely in one hand, so that the System Controller does not fall.
2. If using the nylon clip belt:
 - a. Unclip the nylon clip belt.
 - b. Remove the belt attachment, System Controller, and belt from around the patient's waist.
 - c. Place the items on a stable surface.

OR

3. If using the patient's own belt:
 - a. Unfasten the belt.
 - b. Slide the belt attachment off the belt.
 - c. Place the belt attachment and System Controller on a flat, stable surface.
4. To remove the System Controller from the belt attachment:
 - a. Unclip the two-banded strap from the belt attachment.
 - b. Slide the System Controller out of the belt attachment and place the items on a stable surface.

Using the Consolidated Bag

The Consolidated Bag (**Figure 6.31**) is a slim profile shoulder bag. It allows HeartMate™ patients to comfortably and securely wear and carry system components together in a single bag while using batteries.



Figure 6.31 Consolidated Bag

The Consolidated Bag can be worn across the body using a shoulder strap and supported at the waist using a waist strap.

The compartment that holds the system components is closed using a double zipper. The bag is designed so that the Driveline exits the bag through the protective red tabs on the side (**Figure 6.32**).



Figure 6.32 Wearing the Consolidated Bag (Note Waist Strap)

The Consolidated Bag allows the patient to view the System Controller's user interface. The user interface is visible through a transparent panel beneath a small VELCRO® flap on the outside of the bag.

The Consolidated Bag is available in one color (black) and two configurations depending upon the placement of the patient's Driveline exit site—one configuration for wearing on the right side and one configuration for wearing on the left side. A tag inside the Consolidated Bag indicates whether the bag is intended to be worn on the right or left side.

Assembling the Consolidated Bag

FOR THIS TASK YOU NEED:

- 1 Consolidated Bag with belt
- 1 Consolidated Bag shoulder strap

TO ASSEMBLE THE CONSOLIDATED BAG:

1. Gather equipment; place within easy reach.
2. Clip the shoulder strap to the Consolidated Bag using the two rings located on the top of the Consolidated Bag (**Figure 6.33**).



Figure 6.33 Clip the Strap to the Bag

3. Confirm which side (left or right) the Consolidated Bag is meant to be worn on by the patient.
4. Put the bag on the patient to confirm the appropriate placement on the left or right side.

IMPORTANT! The bag type (left or right) can be found on a tag inside the Consolidated Bag and on the box that it ships in.

5. Adjust the shoulder strap and belt so the bag fits the patient properly. Tighten or lengthen the strap and belt until they are secure but still comfortable.

Putting on the Consolidated Bag

FOR THIS TASK YOU NEED:

- 1 running System Controller on battery power
- 1 assembled Consolidated Bag

TO PUT ON THE CONSOLIDATED BAG:

1. Gather equipment; place within easy reach.
2. Make sure the System Controller power cables and Driveline are not twisted (**Figure 6.34**).



Figure 6.34 Make Sure the Power Cables and Driveline are Not Twisted

3. Prepare the Consolidated Bag for use—unzip the double zippers to open the Consolidated Bag.
4. Slide the System Controller into its holder so the user interface faces out (**Figure 6.35**).



Figure 6.35 Slide the System Controller Into the Holder in the Consolidated Bag

5. Stretch the two-banded strap over the System Controller and between the white System Controller power cable and the Driveline connector. Fasten the clip to hold the System Controller in place (**Figure 6.36**).



Figure 6.36 Stretch the Strap Over the System Controller and Between the Cables

6. Place the first battery into the Consolidated Bag, with the battery clip and cable facing out (**Figure 6.37**).



Figure 6.37 Place the Battery in the Bag

7. Arrange the power cable for the first battery and battery clip so that the cable lays flat along the edge of the bag (**Figure 6.38**).



Figure 6.38 Arrange the Cables Around the Edge of the Bag

- Place the second battery into the Consolidated Bag, with the battery clip and cable facing out (**Figure 6.39**).



Figure 6.39 Place the Second Battery in the Bag

- Arrange the power cables so that they lay flat along the edge of the bag (**Figure 6.40**).



Figure 6.40 Batteries and Cables in Consolidated Bag

- Carefully close the Consolidated Bag, with the System Controller power cables inside the bag and the Driveline between the protective red tabs (**Figure 6.41**).



Figure 6.41 Close the Bag so the Driveline Exits Between the Red Tabs

- Zip both zippers on the Consolidated Bag closed (**Figure 6.42**).



Figure 6.42 Zip Both Zippers Closed

- Hold the Consolidated Bag by the handle so it does not drop.
- Put the shoulder strap over the patient's head and across his or her chest (on either the left or right side of the patient's body, depending on the type of bag), so that the Consolidated Bag rests on the patient's body. Place the waist belt around the patient's body and clip it into place. The belt stabilizes the bag and prevents it from moving.

Taking off the Consolidated Bag

TO TAKE OFF THE CONSOLIDATED BAG:

1. Unclip the belt.
2. Hold the Consolidated Bag using the handle so it does not drop.
3. Take off the shoulder strap—either unclip it at one side, or lift it up and over the patient’s head.
4. Take off the Consolidated Bag; place it in front of the patient.
5. Unzip and open the Consolidated Bag and either:
 - Exchange the depleted batteries for a new, fully-charged pair (see ***Replacing Depleted Batteries*** on page 3-63).
 - OR**
 - Transfer from battery power to the Power Module or Mobile Power Unit (see *Switching from Battery Power to the Power Module* on page 3-69).
 - OR**
 - Remove components from the Consolidated Bag and place them into another wearable accessory.

Using the Battery Holster

The battery holster allows the patient to comfortably and securely wear and carry the system components (batteries, battery clips, and the System Controller) during battery-powered operation.



Figure 6.43 Wearing the Battery Holster

This wearable accessory is designed to secure the batteries and battery clips in holsters, with the weight of the system components distributed across the patient's shoulders and back. A belt attachment is designed to conceal and carry the System Controller. The battery holster is available in one size and is adjustable to accommodate most HeartMate 3™ patients (**Figure 6.43**).

Assembling the Battery Holster

FOR THIS TASK YOU NEED:

- 1 battery holster
- 1 pair of large, sharp scissors
- 1 small tube of strong epoxy glue

TO ASSEMBLE THE BATTERY HOLSTER:

1. Gather equipment; place within easy reach.
2. Place the holster on a flat surface, arranged so the fabric connecting the two straps is in the center.
3. Have the patient slide his or her arms through the straps, so that the fabric connector is between the patient's shoulder blades on his or her back.
4. Pull the loose ends of the strap to adjust the fit. The holsters should fit securely but comfortably against the patient's sides and under the arms.
5. After determining appropriate fit, cut off or trim the extra length from the end of each strap.

Note: Extra strap length can be used later for further adjustment should the patient gain weight.

6. Apply a strong epoxy glue to the cut off ends of each strap to reduce fraying. Allow the glue to dry before wearing the holster.

IMPORTANT! The straps can also be stitched together through the fabric to prevent the fabric connector from moving and changing the fit.

Putting on the Battery Holster

FOR THIS TASK YOU NEED:

- 1 running System Controller on Power Module or Mobile Power Unit power
- 2 fully-charged HeartMate™ 14 Volt Lithium-Ion batteries
- 2 14 Volt battery clips
- 1 battery holster
- 1 belt attachment
- 1 clip-style belt or the patient's own belt

TO PUT ON THE BATTERY HOLSTER:

1. Gather equipment; place within easy reach.
2. Make sure the System Controller power cables and Driveline are not twisted (**Figure 6.44**).



Figure 6.44 Make Sure the Power Cables and Driveline are Not Twisted

3. To insert the batteries and attached battery clips into each holster:
 - a. Open each VELCRO flap (**Figure 6.45**).



Figure 6.45 Open the VELCRO Flap

- b. Insert each battery and attached battery clip into a holster, so the battery points down and the battery clip points up (**Figure 6.46**).



Figure 6.46 Insert a Battery and Battery Clip Into the Holster

- c. Close each holster flap (**Figure 6.47**).



Figure 6.47 Battery in Holster with Flap Closed

- d. Repeat Steps a-c for the second battery and battery clip.
4. Have the patient put on the holster.
5. Put on and secure the belt attachment around the patient's waist. Adjust and tighten the belt as needed.
6. Slide the System Controller into the belt attachment.
7. Stretch the two-banded strap on the belt attachment over the end of the System Controller and between the white System Controller power cable connector and the Driveline connector.

8. Slide the clip ends of the two-banded strap into the clip socket. The clip clicks into place when securely fastened.
9. Transfer from the Power Module or Mobile Power Unit to battery power (see *Switching from the Power Module to Battery-Powered Operation* on page 3-66).

Exchanging Depleted Batteries with Charged Batteries

WARNING !

At least one System Controller power cable must be connected to a power source (Power Module, Mobile Power Unit, or two HeartMate™ 14 Volt Lithium-Ion batteries) at all times.

FOR THIS TASK YOU NEED:

- Patient is wearing a battery holster with running System Controller on battery power
- 2 fully-charged HeartMate 14 Volt Lithium-Ion batteries

TO EXCHANGE DEPLETED BATTERIES WITH A FULLY-CHARGED PAIR:

1. Obtain two fully-charged batteries and place them within easy reach.
2. Exchange each battery, one at a time:
 - a. Open the flap on one of the holsters.

WARNING !

Be sure to remove only one depleted battery from its clip at this time.

- b. Remove the battery and battery clip from the holster.
 - c. Press the battery release button on the battery clip.
 - d. Withdraw the depleted battery from its battery clip and put aside the depleted battery. A Power Cable Disconnected advisory will sound. This is normal.
 - e. Retrieve one of the fully-charged batteries and insert it into the battery clip. It clicks into place when fully inserted. The alarm stops when the fully-charged battery is properly inserted.
 - f. Place the fully-charged battery and attached battery clip into the empty holster.
 - g. Close the holster flap.
 - h. Repeat Steps a-g for the second depleted battery.
3. Recharge the depleted batteries in the Battery Charger (see *Charging HeartMate Batteries* on page 3-80).

Taking Off the Battery Holster

FOR THIS TASK YOU NEED:

- Patient is wearing a battery holster with running System Controller on battery power
- 1 Power Module or Mobile Power Unit

TO TAKE OFF THE BATTERY HOLSTER:

1. Switch from battery power to the Power Module or Mobile Power Unit (see *Switching from Battery Power to the Power Module* on page 3-69).

IMPORTANT! Complete Step 1 before taking off the Battery Holster.

2. Take off the battery holster with batteries.
3. Hold the belt attachment and System Controller securely in one hand, so that the System Controller does not fall.
4. If using the nylon clip belt:
 - a. Unclip the nylon clip belt.
 - b. Remove the belt attachment, System Controller, and belt from around the patient's waist.
 - c. Place the items on a stable surface.

OR

5. If using the patient's own belt:
 - a. Unfasten the belt.
 - b. Slide the belt attachment off the belt.
 - c. Place the belt attachment and System Controller on a stable surface.
6. Remove the System Controller from the belt attachment:
 - a. Unclip the two-banded strap from the belt attachment.
 - b. Slide the System Controller out of the belt attachment and place the items on a stable surface.
7. Remove the batteries and attached battery clips from the holster and place them on a stable surface.
8. Recharge the low-charged batteries (see *Charging HeartMate Batteries* on page 3-80).
9. Store the battery holsters in a clean, dry location (see *Equipment Storage and Care* on page 8-1).

Using the Holster Vest

The holster vest (**Figure 6.48**) allows the patient to comfortably and securely wear and carry system components (batteries, battery clips, and the System Controller) during battery-powered operation (see *Using HeartMate 14 Volt Lithium-Ion Batteries* on page 3-51).

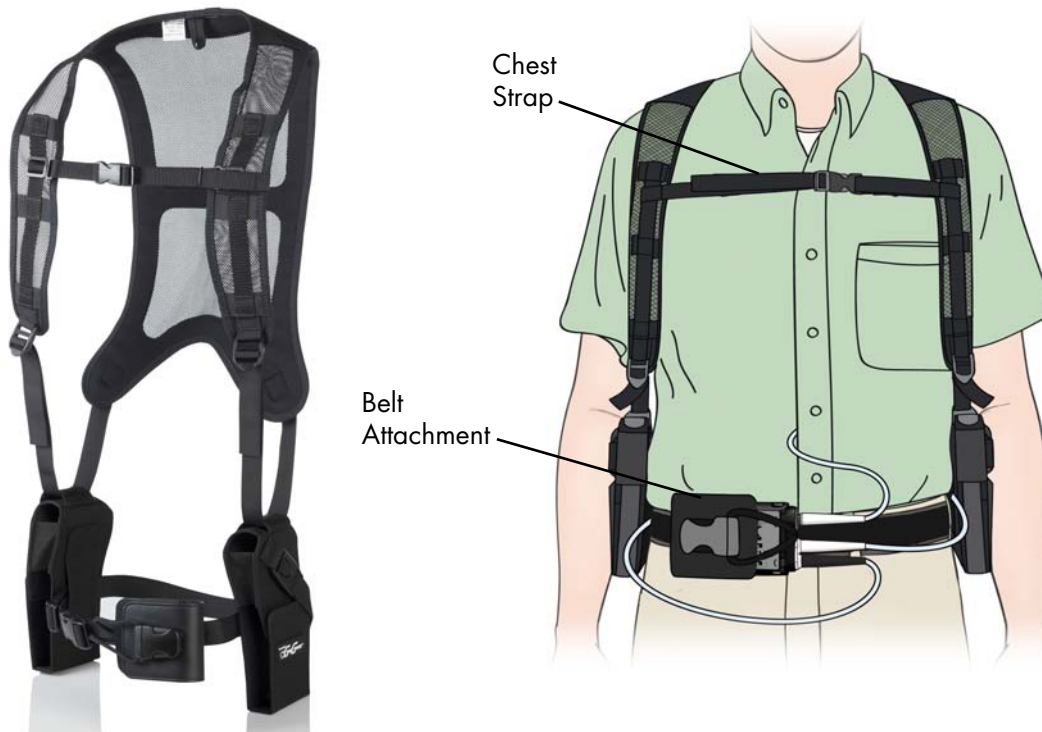

Figure 6.48 Wearing the Holster Vest

The holster vest is designed to distribute the weight of the HeartMate™ system components across the patient's shoulders and back with holsters for the batteries and an optional chest strap.

The holster vest is available in three sizes: small, medium, and large. A belt attachment cover is provided to conceal, protect, and wear the System Controller with the holster vest. The belt attachment cover provides visibility and immediate access to the user interface on the System Controller.

Assembling the Holster Vest

FOR THIS TASK YOU NEED:

- 1 holster vest with belt attachment

TO ASSEMBLE THE HOLSTER VEST:

1. Gather equipment; place within easy reach.
2. Insert one vest strap through the slot in the top of one of the holsters. The buckle should point down and the holster should face forward when the patient wears the vest (**Figure 6.49**).

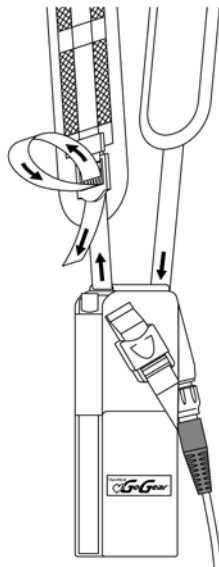

Figure 6.49 Insert Vest Strap Through Slot in Top of Holster

3. Repeat Step 2 for the second holster.

Putting on the Holster Vest

FOR THIS TASK YOU NEED:

- 1 running System Controller on Power Module or Mobile Power Unit power
- 1 assembled holster vest with belt attachment
- 2 fully-charged HeartMate 14 Volt Lithium-Ion batteries

TO PUT ON THE HOLSTER VEST:

1. Gather equipment; place within easy reach.
2. Make sure the System Controller power cables and Driveline are not twisted (**Figure 6.50**).



Figure 6.50 Make Sure the Power Cables and Driveline are Not Twisted

3. To place the batteries and attached battery clips into the holsters:
 - a. Insert one battery and attached battery clip into the holster, so the clip points up and the battery points down (**Figure 6.51**).



Figure 6.51 Insert Battery and Clip into Holster

- b. Buckle the clip on the holster (**Figure 6.52**).



Figure 6.52 Buckle the Clip on the Holster

- c. Close the flap on the holster.
- d. Repeat Steps a–c for the second battery and battery clip.
4. Have the patient put on the holster vest.
5. Adjust and tighten the straps as needed.
6. If the optional chest strap is used, position it higher or lower on the vest as needed, so it is secure and comfortable.
7. Put on and secure the belt attachment around the patient's waist. Adjust and tighten the belt as needed.
8. Slide the System Controller into the belt attachment.
9. Stretch the two-banded strap on the belt attachment over the end of the System Controller, and between the white System Controller power cable connector and the Driveline connector.
10. Slide the clip ends of the two-banded strap into the clip socket. The clip will click into place when securely fastened.
11. Transfer from the Power Module or the Mobile Power Unit to battery power (see *Switching from the Power Module to Battery-Powered Operation* on page 3-66).
12. Use the VELCRO tabs on the back of the holsters to hold the power cables in place and to stabilize the holsters (**Figure 6.53**).

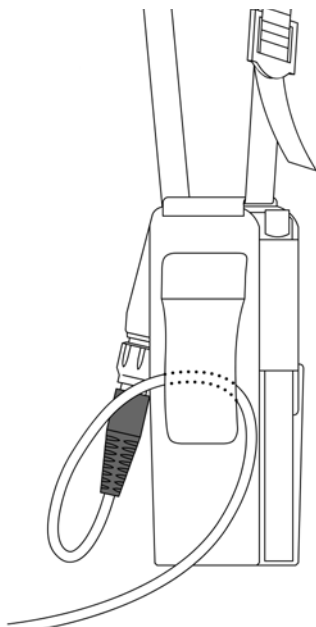

Figure 6.53 Use the VELCRO Tabs to Hold the Power Cables in Place

13. Put the patient's belt through the VELCRO tabs to help secure the holsters in place.

Exchanging Depleted Batteries

WARNING !

At least one System Controller power cable must be connected to a power source (Power Module, Mobile Power Unit, or two HeartMate 14 Volt Lithium-Ion batteries) at all times.

The holster vest allows the convenience of exchanging depleted batteries with a new, fully-charged pair without taking off the vest or disrupting the power cables.

TO EXCHANGE DEPLETED BATTERIES:

1. Obtain two fully-charged HeartMate 14 Volt Lithium-Ion batteries and place them within easy reach.
2. To exchange a depleted battery (**Figure 6.54**):
 - a. Open the flap on one of the holsters to access one of the batteries and attached battery clip.

WARNING !

Remove only one depleted battery at this time.

- b. Hold the battery while pressing the battery release button on the battery clip.
- c. Withdraw the depleted battery from its battery clip. An alarm will sound when the battery is removed. This is normal.
- d. Retrieve one of the fully-charged batteries and insert it into the empty battery clip. It clicks into place when fully inserted. The alarm stops when the battery is inserted.
- e. Close the flap on the holster.

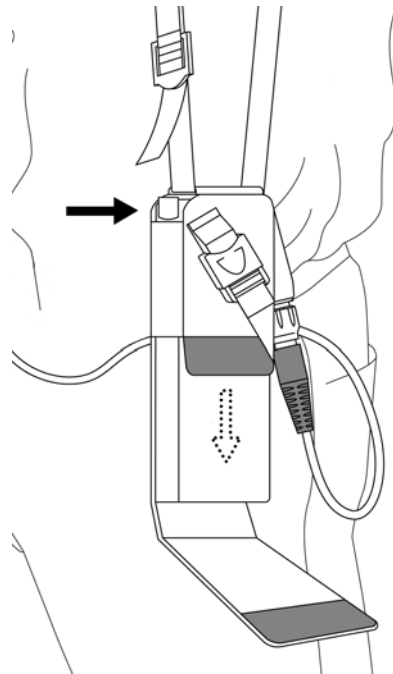

Figure 6.54 Exchanging a Battery

3. Repeat Step 2 to exchange the second depleted battery.
4. Recharge the depleted batteries (see *Charging HeartMate Batteries* on page 3-80).

Taking Off the Holster Vest

TO TAKE OFF THE HOLSTER VEST:

1. Switch from battery power to the Power Module or the Mobile Power Unit (see *Switching from Battery Power to the Power Module* on page 3-69).

IMPORTANT! Complete Step 1 before taking of the Holster Vest.

2. Take off the holster vest with batteries.
3. Hold the belt attachment and System Controller securely in one hand, so that the System Controller does not fall.
4. If using the nylon clip belt:
 - a. Unclip the nylon clip belt.
 - b. Remove the belt attachment, System Controller, and belt from around the patient's waist.
 - c. Place the items on a stable surface.

OR

5. If using the patient's own belt:
 - a. Unfasten the belt.
 - b. Slide the belt attachment off the belt.
 - c. Place the items on a stable surface.
6. Remove the System Controller from the belt attachment:
 - a. Unclip the two-banded strap from the belt attachment.
 - b. Slide the System Controller out of the belt attachment and place the items on a stable surface.
7. Remove the batteries and attached battery clips from the holster vest and place them on a stable surface.
8. Recharge the low-charged batteries (see *Charging HeartMate Batteries* on page 3-80).
9. Store the holster vest in a clean, dry location (see *Equipment Storage and Care* on page 8-1).

Using the Protection Bag

The Protection Bag (**Figure 6.55**) stores and protects the backup System Controller while it is in Sleep Mode. The Protection Bag has a clear window for easy viewing of the System Controller and power cables inside. The bag protects the equipment from dust, dirt, moderate water, and debris. It also provides a convenient way to store or carry the backup System Controller, which must remain with the patient at all times. The Protection Bag fits into the Travel Bag.

FOR THIS TASK YOU NEED:

- 1 Protection Bag
- 1 backup System Controller and cables

TO USE THE PROTECTION BAG:

1. Unzip the Protection Bag.
2. Slide the backup System Controller into the Protection Bag.
3. Carefully coil the cables around the System Controller inside the Protection Bag.
4. Zip closed the Protection Bag (**Figure 6.55**).



Figure 6.55 Protection Bag with Backup Controller and Cables Stored Inside

IMPORTANT! When placing the System Controller inside the Protection Bag, do not twist, kink, or sharply bend the System Controller power cables, which may cause damage to the wires inside, even if external damage is not visible. If the cables become twisted, bent, or kinked, carefully unravel and straighten. See *What Not To Do: Driveline and Cables* on page 7-46.

IMPORTANT! Do not store or carry anything in the Protection Bag other than the backup System Controller and attached power cables.

IMPORTANT! Maintain the backup System Controller and spare batteries within the recommended environmental conditions. Refer to *Acceptable Operating Conditions* on page 2-6.

Using the Travel Bag

The Travel Bag accommodates a System Controller in its Protection Bag, along with spare batteries. The Travel Bag provides a convenient way to carry and transport the backup System Controller and spare batteries. The Travel Bag can also be used at home to hold the backup System Controller (**Figure 6.56**).



Figure 6.56 Travel Bag

FOR THIS TASK YOU NEED:

- 1 Protection Bag with backup System Controller and cables stored inside
- 2 spare fully-charged 14 Volt Lithium-Ion batteries
- 1 Travel Bag

TO USE THE TRAVEL BAG:

1. Open the top lid, unzip the inner compartment, and open the Travel Bag.
2. Place the Protection Bag (with the backup System Controller and cables inside) into the Travel Bag (**Figure 6.57**).



Figure 6.57 Insert the Protection Bag Into the Travel Bag

3. Place fully-charged, spare batteries into the side pockets of the Travel Bag (**Figure 6.58**).



Figure 6.58 Insert Spare Batteries Into the Travel Bag

4. Zip closed the inner compartment and snap shut the top lid.

WARNING !

The Left Ventricular Assist Device will stop if the Driveline is disconnected from the System Controller. If the Driveline is disconnected, reconnect it as quickly as possible to restart the pump. If the System Controller does not work, replace it with a backup System Controller that is programmed with patient-specific settings.

IMPORTANT! Maintain the backup System Controller and spare batteries within the recommended environmental conditions. Refer to *Acceptable Operating Conditions* on page 2-6.

Preparing for Sleep

HeartMate 3™ patients must be attached to the Power Module or the Mobile Power Unit during sleep or any time when sleep is likely. During sleep, the System Controller and Driveline must be immobilized to reduce movement or pulling on the Driveline exit site. Driveline stabilization must be used to immobilize the Driveline and System Controller.

WARNING !

The patient must always connect to the Power Module or the Mobile Power Unit for sleeping, or when there is a chance of sleep. A sleeping patient may not hear the System Controller alarms.

- A patient should sleep or plan to sleep only when connected to the Power Module or the Mobile Power Unit. If a patient falls asleep during battery-powered operation, the low battery alarms may not awaken the patient before battery depletion.
- Prior to sleep, inspect and make sure that all electrical connections are secure.
- A patient should not sleep on his or her stomach.
- Keep the replacement System Controller nearby for convenient access in the event of an emergency that requires replacement of the running System Controller.
- Keep a flashlight, fully-charged batteries, and battery clips within reach to be prepared for a power outage.

Ongoing System Assessment and Care

Caring for the Driveline

It is extremely important that the Driveline be protected from extreme or frequent bending or kinking. Damage to the Driveline, depending on the degree, may cause the pump to stop.

The patient must be educated about the importance of keeping the Driveline free from damage. Routinely reinforce the importance of adhering to the following guidelines for Driveline care:

- Mangle the Driveline Exit Site in accordance with the procedure provided by the clinician.
- Do not severely bend or kink the Driveline.
- Do not let the Driveline become twisted.
- If carrying the System Controller in a carrying case, keep the Driveline away from the zipper.
- Allow for a gentle curve of the Driveline. Do not severely bend the Driveline multiple times or wrap it tightly.
- Keep the Driveline clean. Wipe off any dirt or grime that may appear. If necessary, use a towel with soap and warm water to gently clean the Driveline. However, never submerge the Driveline or other system components in water or liquid. See *Care of the Driveline* on page 8-5 for information about caring for the Driveline.
- Do not pull on or move the Driveline going through the skin.
- When checking to ensure that the Driveline connector is fully inserted into the System Controller Driveline socket, gently tug on the metal end of the connector. Do not move or pull on the Driveline.
- Check that the Modular inline Connector is properly connected and that the lock is secured.
- Be mindful of where the System Controller is at all times. Protect the System Controller from falling or from pulling on the Driveline.
- Do not allow the Driveline to catch or snag on anything that can pull on or move the Driveline.
- Check the Driveline daily for signs of damage, such as cuts, holes, or tears. Counsel patients to inform you immediately if they find signs of Driveline damage.

- Damage due to wear and fatigue of the Driveline has occurred in both the externalized and implanted portions of the Driveline. Damage to the electrical conductors within the Driveline may or may not be preceded by visible damage to the outer layer of the Driveline. Driveline damage may be evidenced by the following:
 - A Driveline Communication Fault (Driveline Comm Fault) or Driveline Power Fault on the System Controller.
 - Transient alarms due to short or open circuits, often associated with movement of the patient or the lead.
 - Fluid leakage from the external portion of the Pump Cable.
 - Pump stopping.

If the Driveline or Modular inline Connector appears damaged, please contact Abbott for assistance. See Abbott contact information on the *Back Cover* of this manual. X-ray images and System Controller log files are useful to assess the extent and location of the damage. If the Driveline or Driveline conductors are damaged internal to the patient's body, the pump should be replaced as soon as possible. If it has been determined that the damage has been detected in the Modular Cable portion of the Driveline, it can be replaced. Please refer to *Replacing the Modular Cable* on page 2-62 for the procedure for exchanging the Modular Cable.

CAUTION !

- The HeartMate 3™ Left Ventricular Assist System uses lights and sounds to indicate how it is working. If the patient has trouble hearing or seeing, he or she may need extra help to hear or see the lights and sounds.
- To avoid pulling on or moving the Driveline at the exit site, the patient must stabilize their Driveline at all times. Pulling on or moving the Driveline can keep the exit site from healing or damage an already healed exit site. Exit site trauma or tissue damage can increase the patient's risk of getting a serious infection. Emphasize to the patient and/or family member or caregiver the importance of not pulling on or moving the Driveline.
- Do not twist, kink, or sharply bend the Driveline, System Controller power cables, Power Module patient cable, or Mobile Power Unit patient cable, which may cause damage to the wires inside, even if external damage is not visible. Damage to the Driveline or cables could cause the Left Ventricular Assist Device to stop. If the Driveline or cables become twisted, kinked, or bent, carefully unravel and straighten. See *What Not To Do: Driveline and Cables* on page 7-46.

Caring for the System Controller Power Cables

It is extremely important that the System Controller power cables be protected from kinks, sharp bends, and repeated bending. This is especially applicable if the patient is active. Damage to the power cables, depending on the degree, may impair pump function.

The patient must be educated about the importance of keeping the System Controller power cables free from damage. Routinely reinforce the importance of adhering to the following guidelines for power cable care:

- Do not kink or sharply bend the power cables, especially near the strain relief portion of the System Controller connectors (where the connector and cable meet). See **Figure 6.59**.
- Avoid repeated bending of the power cables, especially near the connectors.
- When carrying the System Controller in a bag, case, or other carrier, do not kink or sharply bend the power cables, especially near the connectors.
- When carrying the System Controller in a zippered carrying case, keep the power cables away from the zipper.
- Do not let the power cables become twisted.



Figure 6.59 Do Not Bend System Controller Power Cables

Educating and Training Patients, Families, and Caregivers

During the patient selection, preimplant, and postoperative period, the patient must receive instructions regarding the operation and care of every system component. Consider using a Competency Assessment Checklist to test and measure discharge readiness of patients and their family members or caregivers.

At a minimum, you must discuss the following topics when training the patient (and his or her family members or caregivers):

1. Remember to give the *Patient Handbook* to the patient.
2. General information
 - General assessment of caregiver/patient support systems
 - Concept of ventricular assistance
 - How the Left Ventricular Assist Device pumps blood
 - Control modes
 - Battery-powered versus Mobile Power Unit operation
 - Battery use regimen
 - Advisory and Hazard alarms: including their meaning and how to recognize and respond to them
 - Medical Alert ID Bracelet (recommended)
 - Maintenance and periodic safety checks
 - Daily, weekly, monthly, six month, and yearly safety checklists
 - Anticoagulation
3. System components
 - Left Ventricular Assist Device
 - Driveline
 - System Controller
 - System Controller connectors for Driveline and power cables
 - System Controller power cables
 - Charging the backup battery in the backup System Controller
 - HeartMate™ 14 Volt Lithium-Ion batteries and battery clips
 - Using, charging, testing, and calibrating HeartMate 14 Volt Lithium-Ion batteries
 - Battery Charger

- Mobile Power Unit
4. Using the wear and carry accessories to hold and carry system components
 5. Operating the system
 - Making connections
 - Changing power sources
 - Performing a System Controller self test
 6. What to do in an emergency
 - What is an emergency (clinical emergency versus equipment emergency)
 - Steps to take in an emergency
 - Emergency transportation plan
 - Preparing for and practicing emergency procedures
 - How to diagnose power or connector problems
 - Emergency telephone contacts
 - Replacing the running System Controller with the backup System Controller
 7. Driveline Exit Site Management
 8. Showering
 9. Preparing for sleep
 10. Travel
 11. Warnings and cautions

ALARMS AND TROUBLESHOOTING

This section describes the primary alarms and troubleshooting of the HeartMate 3 Left Ventricular Assist System.

System Controller Alarms - - - - -	7-2
HeartMate Touch™ App Alarms - - - - -	-7-25
Handling Power Module Alarms - - - - -	-7-37
Mobile Power Unit Alarms - - - - -	-7-40
Using the Charger to Check Battery or Charger Status - - - - -	-7-42
Guidelines for Power Cable Connectors - - - - -	-7-45
What Not To Do: Driveline and Cables - - - - -	-7-46

System Controller Alarms

Patient-Resolvable Versus Clinician-Resolvable Alarms

Note: Patients can resolve and troubleshoot many System Controller alarms on their own, without clinician intervention. Primarily, patient-resolvable alarms involve maintaining connections to the Driveline and external power sources. There are, however, many situations where clinician help is needed. In these situations, a “Call Hospital Contact” message appears on the information display screen. Depending on the hospital center, the clinician may ask the patient to replace his or her System Controller. In other cases, the clinician may arrange for the patient to be admitted for additional diagnostics and resolution by clinicians.

Handling System Controller Alarms

Common System Controller alarms are described on the following pages. Each section addresses the likely cause and typical steps for resolving most System Controller alarms. Alarms are presented in order of priority. Hazard alarms appear first, followed by Advisories. See **Table 7.2** through **Table 7.4** on the following pages for a complete list of prioritized System Controller alarms.

IMPORTANT! System Controller alarms cannot be silenced when the System Controller is in power saver mode. For more information about power saver mode, see *Low Speed Limit* on page 4-27.

Alarm Screen Overview

When an alarm occurs, messages appear on the System Controller’s user interface screen to help resolve the problem. These screen messages indicate the alarm type as well as how long the alarm has been occurring. The timer on the screen counts up in seconds, indicating how long the alarm has been occurring. **Figure 7.1** shows the alarm screen layout.

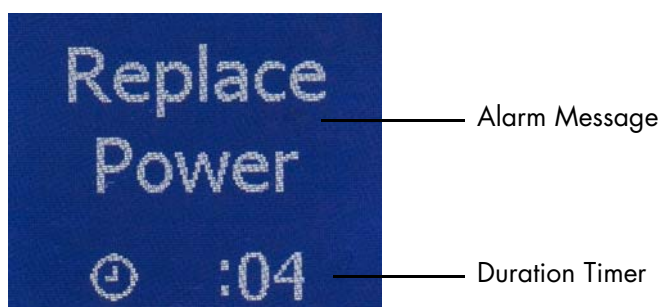

Figure 7.1 Alarm Screen

Viewing Alarm History on the User Interface Screen

You can view alarm history on the System Controller user interface. The last six relevant System Controller alarms are displayed. The alarm history includes alarms that are transient, have clinical value, or that do not interfere with access to more critical alarms. Examples of alarms that are displayed include:

- Power Cable Disconnected Alarm (lasting over 30 seconds)
- External Power Disconnected Alarm
- Driveline Disconnected Alarm
- Low Battery Power Advisory Alarm
- Low Battery Power Hazard Alarm
- Low Flow Alarm

Only a subset of alarms is displayed on the System Controller; a history of all alarms is available through the HeartMate Touch™ App (see *Event Records | Periodic Records* on page 4-63).

To view the six most recent alarms on the user interface screen, simultaneously press and release the silence alarm (⊗) and display (□) buttons. Up to six of the most recent alarms are displayed. The most recent alarm appears first. To view the next alarm, press and release the display (□) button. Each push of the display button brings up a new screen. After the sixth alarm is displayed, the next button push returns you to the first alarm screen.

Alarm history screens show the date and time of the alarm occurrence at the top of the screen. A dot at the bottom of each screen provides navigational information about which screen is in view (see **Figure 7.2**).

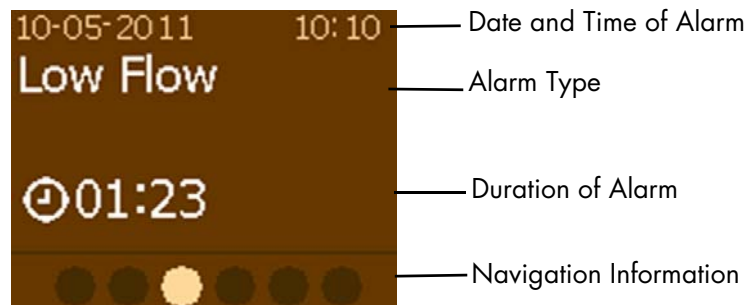

Figure 7.2 Sample Alarm History Screen

Table 7.1 shows how to access the alarm history screens.











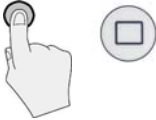

Button Press	Description	Alarm Screen Displayed (Example)
<p>Press</p>  <p>AND</p> 	<p>Press display button and silence alarm button at the same time to access first alarm.</p>	
<p>Press</p> 	<p>Press display button ONCE to display the second alarm.</p>	
<p>Press</p> 	<p>Press display button TWO times to display the third alarm.</p>	
<p>Press</p> 	<p>Press display button THREE times to display the fourth alarm.</p>	
<p>Press</p> 	<p>Press display button FOUR times to display the fifth alarm.</p>	
<p>Press</p> 	<p>Press display button FIVE times to display the sixth alarm.</p>	

Table 7.1 Viewing Alarm History Screens

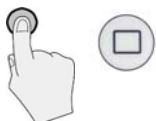
If the System Controller detects an alarm condition while displaying alarm history, the screen immediately transitions to the real-time alarm screen. However, you can still access the alarm history screens during an active alarm by simultaneously pressing the silence alarm (⊗) and display (□) buttons. To exit from the alarm history feature, simultaneously press the two buttons again.

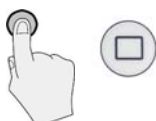
Alarms That Do Not Appear in Alarm History

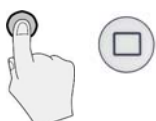
The Driveline Power Fault, Driveline Communication Fault (Driveline Comm Fault), System Controller Backup Battery Fault, and System Controller Fault alarms are examples of non-transient alarms that require specific user action to resolve the alarm condition. These alarms remain on the user interface screen until the alarm condition is resolved or permanently disabled, and therefore do not appear in alarm history.

In addition, a Power Cable Disconnected advisory alarm (that lasts less than 30 seconds) and Pulsatility Index (PI) events are examples of routine events that might interfere with access to more critical information. For this reason, these events also do not appear in alarm history.

The following alarms do not appear on the System Controller: Low Speed, LVAD Fault, Controller Clock Not Set.

Available Languages

On-screen messages on the user interface can be displayed in multiple languages. Use the HeartMate Touch App to view and select the desired language (see *System Controller Language* on page 4-37).

Alarm Silence Indicator - System Controller LCD Screen

If the audio alarm silence has been activated from either the System Controller or the HeartMate Touch App, the System Controller LCD screen will display the alarm silence indicator (⊗).



Figure 7.3 Sample Alarm Silence Indicator













Priority	System Controller Screen	Active Symbols	Silence Period	Alarm Means	To Resolve Alarm	
H A Z A R D	Call Hospital Contact @23:01 + Low Flow @23:02	 	2 minutes	Pump is off. The Pump Running symbol is black.	1. Check if the fixed speed setting is below 4000 rpm AND the System Controller's backup battery is not installed. Under these conditions, the pump can only be started from the System Monitor's Clinical or Settings screen by pressing the Pump Start button. Otherwise, press any button on the System Controller to attempt pump start. 2. Switch to the backup System Controller and attempt to restart pump. 3. Clinically evaluate patient.	
						See page 7-10.
	Connect Power Immediately @ :03 + Backup Battery @ :07	   +  + 	2 minutes	Pump has stopped running, MPU power has failed possibly due to static electricity.	1. Immediately connect to HeartMate 14 Volt Lithium-Ion batteries. 2. If restoring power does not resolve, press any button on the System Controller to attempt pump starts.	
						See page 7-11.
	Call Hospital Contact @23:01 + Low Flow @23:02	 	2 minutes	Low flow, flow is less than 2.5 lpm	1. Ensure that the Driveline is connected to System Controller. 2. Ensure that a power source is connected to System Controller. 3. Clinically evaluate patient.	
					See page 7-12.	
	Connect Driveline @ :01	  + 	2 minutes	Driveline is disconnected. The Pump Running symbol is black.	1. Immediately reconnect the Driveline to System Controller and move the Driveline Safety Lock on the System Controller to the locked position. Also check that the Modular inline connector is secure. 2. If alarm persists after reconnecting the Driveline, press any button on the System Controller to attempt pump start. 3. If the alarm still persists, check if the fixed speed setting is below 4000 rpm AND the System Controller's backup battery is not installed. Under these conditions, the pump can only be started from the System Monitor's Clinical or Settings screen by pressing the Pump Start button. 4. If Driveline is connected and alarm persists, replace System Controller with a configured backup System Controller.	
					See page 7-13.	

Table 7.2 System Controller Hazard Alarms







Priority	System Controller Screen	Active Symbols	Silence Period	Alarm Means	To Resolve Alarm
H A Z A R D	<p>Connect Power Immediately ⌚ 3:01</p> <p>+</p> <p>Backup Battery ⌚ 23:01</p>	  	2 minutes	Both power cables are disconnected.	<p>Immediately connect to a working power source (Power Module, Mobile Power Unit, or two HeartMate 14 Volt Lithium-Ion batteries).</p> <p>See page 7-14.</p>
	<p>Call Hospital Contact Controller Fault</p>	 	None - the audio tone cannot be silenced	System Controller Hardware Fault (Microcontroller Failure)	<p>No active symbols (constant audio tone).</p> <ol style="list-style-type: none"> 1. Immediately switch to the backup System Controller. 2. Provide patient with a new System Controller. <p>See page 7-16.</p>
	<p>Low Battery ⌚ 23:01</p> <p>+</p> <p>Replace Power Immediately ⌚ 23:02</p>		2 minutes	Low Battery, Power input is extremely low with less than 5 min. remaining.	<p>Immediately connect to a working power source (Power Module, Mobile Power Unit, or two HeartMate 14 Volt Lithium-Ion batteries).</p> <p>See page 7-15.</p>

Table 7.2 System Controller Hazard Alarms (Continued)







Priority	System Controller Screen	Active Symbols	Silence Period	Alarm Means	To Resolve Alarm
A D V I S O R Y	Connect Power ⌚ 23:01	 OR 	2 minutes	One of the two power cables is disconnected.	Promptly connect the disconnected power cable to power source (functioning Power Module, Mobile Power Unit, or two fully-charged HeartMate 14 Volt Lithium-Ion batteries). See page 7-17.
	Replace Power ⌚ :02 + Low Battery ⌚ :06		5 minutes	Low Battery, Power input is low with less than 15 min. remaining	Promptly connect to a working or different power source (Power Module, Mobile Power Unit, or two fully-charged HeartMate 14 Volt Lithium-Ion batteries). See page 7-18.
	Call Hospital Contact Controller Fault		4 hours	System Controller Hardware Fault	1. Switch to the backup System Controller. 2. Provide patient with a new System Controller (with backup battery installed). See page 7-19.
	Call Hospital Contact Comm Fault		4 hours	Communication Fault (Comm Fault)	Contact Abbott to determine best next steps: Use the HeartMate Touch App to silence the alarm while awaiting resolution, if needed. Note: The alarm must be active in order to access the extended alarm silence for this situation. See page 7-20.
	Call Hospital Contact Backup Battery Fault		4 hours	System Controller Backup Battery Fault	Replace the 11 Volt Lithium-Ion backup battery. Note: If replacing the battery does not resolve the alarm, the System Controller may need to be replaced, or additional steps may be required. Call Abbott with questions. See page 7-21.

Table 7.3 System Controller Advisory Alarms







Priority	System Controller Screen	Active Symbols	Silence Period	Alarm Means	To Resolve Alarm
A D V I S O R Y	 		4 hours	System Controller Backup Battery Not Installed	1. Install the 11 Volt Lithium-Ion backup battery in the System Controller. 2. Obtain a new backup battery replacement kit. Note: If replacing the battery does not resolve the alarm, the System Controller may need to be replaced, or additional steps may be required. Call Abbott with questions. See page 7-22.
			4 hours	Driveline Power Fault	Contact Abbott to determine best next steps. Use the HeartMate Touch App to silence the alarm while awaiting resolution, if needed. Note: The alarm must be active in order to access the alarm silence for this situation. See page 7-23.
			4 hours	Driveline Communication Fault (Driveline Comm Fault)	Contact Abbott to determine best next steps. Use the HeartMate Touch App to silence the alarm while awaiting resolution, if needed. Note: The alarm must be active in order to access the alarm silence for this situation. See page 7-24. Then see <i>Driveline Communication Fault Alarm</i> on page 4-49.

Table 7.4 System Controller Advisory Alarms

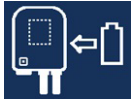
IMPORTANT! The Pump Running () light is always green (ON) when the pump is running.

Pump Off Alarm

This is a Hazard alarm	
<p>The screens look like this:</p> <p>(alternating screens)</p>	
<p>Behavior and appearance:</p>	<ul style="list-style-type: none"> • Flashing Red Heart (❤️) on the user interface. • The Driveline is connected. • “Call Hospital Contact” and “Low Flow” alternate on the screen. • Green “Pump Running” symbol (⌚) is black. • Alarm tone: Constant tone. • HeartMate Touch App alarm active: PUMP OFF
<p>Alarm means:</p>	<p>Pump has stopped running, possibly because power has been disconnected or failed.</p>
<p>To resolve alarm:</p>	<p>Patient must immediately connect to a power source (if disconnected/failed). If restoring power does not resolve, patient should press any button on the System Controller to attempt pump start, and immediately call hospital contact for diagnosis and instructions.</p> <p>Clinicians:</p> <ol style="list-style-type: none"> 1. Check if the fixed speed setting is below 4000 rpm AND the System Controller’s backup battery is not installed. Under these conditions, the pump can only be started from the HeartMate Touch App Clinical view by tapping START PUMP. Otherwise, press any button on the System Controller to attempt pump start. 2. Switch to backup System Controller and attempt to restart pump. See page 2-54. 3. Clinically evaluate patient.
<p>Alarm silence period:</p>	<ul style="list-style-type: none"> • 2 minutes or until a new hazard alarm occurs. • To silence this alarm, press the silence alarm button (🔇).

Table 7.5 Pump Off Alarm

Pump Stop and No External Power Alarm

This is a Hazard alarm	
<p>The screens look like this:</p> <p>(alternating screens)</p>	
<p>Behavior and appearance:</p>	<ul style="list-style-type: none"> • Flashing Red Heart (❤️) on the user interface. • The Driveline is connected. • The MPU is connected. • “Connect Power Immediately” and “Backup Battery” alternate on the screen. • The “Pump Running” symbol (🔄) is black. • Flashing yellow lights next to the power cables • Flashing red battery (🔋) • Alarm tone: Constant tone.
<p>Alarm means:</p>	<p>Pump has stopped running, MPU power has failed possibly due to static electricity.</p>
<p>To resolve alarm:</p>	<ol style="list-style-type: none"> 1. Immediately connect to HeartMate 14 Volt Lithium-Ion batteries. 2. If restoring power does not resolve, press any button on the System Controller to attempt pump restart.
<p>Alarm silence period:</p>	<ul style="list-style-type: none"> • 2 minutes or until a new hazard alarm occurs. • To silence this alarm, press the silence alarm button (🔇).

Table 7.6 Pump Stop and No External Power Alarm

Low Flow Alarm



This is a Hazard alarm	
<p>The screens look like this: (alternating screens)</p>	
<p>Behavior and appearance:</p>	<ul style="list-style-type: none"> • Flashing Red Heart () on the user interface. • “Call Hospital Contact” and “Low Flow” alternate on the screen. • Alarm tone: Constant tone. • HeartMate Touch App alarm active: LOW FLOW
<p>Alarm means:</p>	<p>Pump flow is less than 2.5 lpm.</p>
<p>To resolve alarm:</p>	<p>Patients must call their hospital contact immediately for diagnosis and instructions.</p> <p>Clinicians should:</p> <ol style="list-style-type: none"> 1. Ensure the Driveline is connected to the System Controller. See page 2-22. 2. Ensure that a power source is connected to the System Controller. 3. Clinically evaluate patient.
<p>Alarm silence period:</p>	<ul style="list-style-type: none"> • 2 minutes or until a new hazard alarm occurs. • To silence this alarm, press the silence alarm button ().

Table 7.7 Low Flow Alarm

Driveline Disconnected Alarm





This is a Hazard alarm	
The screen looks like this:	
Behavior and appearance:	<ul style="list-style-type: none"> • Flashing Red Heart () on the user interface. • Flashing red light near Driveline connector. • “Connect Driveline” flashes on the screen. • Green “Pump Running” symbol () is black. • Alarm tone: Constant tone. • HeartMate Touch App alarm active: DRIVELINE DISCONNECTED
Alarm means:	The Driveline is disconnected from the System Controller. See page 2-20.
To resolve alarm:	<ol style="list-style-type: none"> 1. Immediately reconnect the Driveline to the System Controller and move the Driveline Safety Lock on the System Controller to the locked position. Also, check that the Modular inline Connector is secure. See page 2-22. 2. If alarm persists after reconnecting the Driveline, press any button on the System Controller to attempt pump start. 3. If the alarm still persists, check if the fixed speed setting is below 4000 rpm AND the System Controller’s backup battery is not installed. Under these conditions, the pump can only be started from the HeartMate Touch App Clinical view by tapping START PUMP. 4. If Driveline is connected and alarm persists, replace the System Controller with a configured backup System Controller.
Alarm silence period:	<ul style="list-style-type: none"> • 2 minutes or until a new hazard alarm occurs. • To silence this alarm, press the silence alarm button ().

Table 7.8 Driveline Disconnected Alarm

No External Power Alarm



This is a Hazard alarm	
<p>The screens look like this:</p> <p>(alternating screens)</p>	
<p>Behavior and appearance:</p>	<ul style="list-style-type: none"> • Flashing Red Battery () on the user interface. • “Connect Power Immediately” and Backup Battery graphic alternate on the screen. • Yellow light near the black power cable connector is flashing. • Yellow light near the white power cable connector is flashing. • Alarm tone: Constant tone. • HeartMate Touch App alarm active: NO EXTERNAL POWER
<p>Alarm means:</p>	<p>1. The System Controller is not receiving power from either power cable.</p> <p>AND</p> <p>2. The pump is being powered by the System Controller’s 11 Volt Lithium-Ion backup battery.</p>
<p>To resolve alarm:</p>	<p>Immediately connect to a functioning Power Module, Mobile Power Unit, or two fully-charged HeartMate 14 Volt Lithium-Ion batteries to ensure the pump does not stop.</p>
<p>Alarm silence period:</p>	<ul style="list-style-type: none"> • 2 minutes or until a new hazard alarm occurs. • To silence this alarm, press the silence alarm button ().

Table 7.9 No External Power Alarm

The 11 Volt Lithium-Ion backup battery inside the System Controller provides power to the pump for at least 15 minutes when fully charged if the main power source is disconnected or fails. See *System Controller Backup Battery Power* on page 2-39 for details about the 11 Volt Lithium-Ion backup battery inside the System Controller.

IMPORTANT! If external power is not restored, the pump gradually slows to the low speed limit to save power in an effort to prevent the pump from stopping. When adequate power is supplied, the pump reverts to the previous speed and the red battery alarm clears.

Low Battery Power Alarm (less than 5 minutes remain)



This is a Hazard alarm	
<p>The screens look like this:</p> <p>(alternating screens)</p>	
<p>Behavior and appearance:</p>	<ul style="list-style-type: none"> • Flashing Red Battery () on the user interface. • “Low Battery” and “Replace Power Immediately” alternate on the screen. • Alarm tone: Constant tone. • HeartMate Touch App alarm active: LOW VOLTAGE
<p>Alarm means:</p>	<ul style="list-style-type: none"> • Less than 5 minutes of battery power remains (when using battery power). <p>OR</p> <ul style="list-style-type: none"> • The System Controller is receiving inadequate power from the Power Module or Mobile Power Unit.
<p>To resolve alarm:</p>	<p>Immediately connect to a working power source (Power Module, Mobile Power Unit, or two HeartMate 14 Volt Lithium-Ion batteries).</p>
<p>Alarm silence period:</p>	<ul style="list-style-type: none"> • 2 minutes or until a new hazard alarm occurs. • To silence this alarm, press the silence alarm button ().

Table 7.10 Low Battery Power Alarm (< 5 minutes)

System Controller Hardware Fault



This is a Hazard alarm	
The screen looks like this:	
Behavior and appearance:	<ul style="list-style-type: none"> • All symbols are off, including the “pump running” symbol () and wrench (). • “Call Hospital Contact; Controller Fault” displayed on the screen. • The Driveline is connected and power is connected. • Alarm tone: Constant tone. • All Controller buttons are non-functional. • No HeartMate Touch Communication System communication, alarm will not appear on the HeartMate Touch App.
Alarm means:	<p>The microcontroller inside the System Controller is not functioning. Power is passing directly from the source, through the System Controller to the pump. The pump will continue to operate as long as power is applied to the System Controller and no other malfunction occurs. All other monitoring and alarms are not functional (including an indication of pump operation).</p>
To resolve alarm:	<p>Patients must call their hospital contact immediately for diagnosis and instructions. Switch to the backup System Controller if instructed to.</p> <p>Clinicians should:</p> <ol style="list-style-type: none"> 1. Switch to the backup System Controller 2. Provide patient with a new System Controller
Alarm silence period:	<p>None - the audio tone cannot be silenced</p>

Table 7.11 System Controller Hardware Fault

IMPORTANT! A backup System Controller is identical to the running System Controller. It should remain with the patient at all times for easy access in an emergency. See *The Backup System Controller* on page 2-45 for details about the backup System Controller, including replacement instructions. See page 2-54.

Power Cable Disconnected Alarm



This is an Advisory alarm	
<p>The screens look like this:</p> <p>(Screen 1 for black cable; Screen 2 for white cable)</p>	<p>Screen 1 – Black cable</p>  <p>Screen 2 – White cable</p> 
<p>Behavior and appearance:</p>	<ul style="list-style-type: none"> • Flashing yellow light near the black or white power cable connector, depending on which cable is disconnected. • “Connect Power” appears on the screen. • Alarm tone: Fast beep. • HeartMate Touch App alarm active: Power Cable Disconnected
<p>Alarm means:</p>	<p>One of the System Controller power cables is disconnected from power. If it is the cable with the black connector, the top light comes on. If it is the cable with the white connector, the center light comes on.</p>
<p>To resolve alarm:</p>	<p>Promptly connect the disconnected power cable to a power source (functioning Power Module, Mobile Power Unit, or two fully-charged HeartMate 14 Volt Lithium-Ion batteries).</p>
<p>Alarm silence period:</p>	<ul style="list-style-type: none"> • 2 minutes or until a new hazard alarm occurs. • To silence this alarm, press the silence alarm button (⊗).

Table 7.12 Power Cable Disconnected Alarm

Low Battery Power Alarm (less than 15 minutes remain)



This is an Advisory alarm	
<p>The screens look like this: (alternating screens)</p>	
<p>Behavior and appearance:</p>	<ul style="list-style-type: none"> • Flashing yellow diamond (◆) on the user interface. • "Low Battery" and "Replace Power" alternate on the screen. • Alarm tone: Slow beep. • HeartMate Touch App alarm active: Low Voltage Advisory
<p>Alarm means:</p>	<p>Low battery, power input to the System Controller is low with less than 15 minutes of battery power remaining.</p>
<p>To resolve alarm:</p>	<p>Promptly connect to a working or different power source (Power Module, Mobile Power Unit, or two HeartMate 14 Volt Lithium-Ion batteries).</p>
<p>Alarm silence period:</p>	<ul style="list-style-type: none"> • 5 minutes or until any new alarm occurs. • To silence this alarm, press the silence alarm button ().

Table 7.13 Low Battery Power Alarm (< 15 minutes)

WARNING !

Do not connect a System Controller to both the Mobile Power Unit and the Power Module at the same time, or damage to the System Controller and injury to the patient may occur. First connect to HeartMate 14 Volt batteries.

System Controller Fault Alarm



This is an Advisory alarm	
The screen looks like this:	
Behavior and appearance:	<ul style="list-style-type: none"> • Flashing yellow wrench () on the user interface. • “Call Hospital Contact; Controller Fault” on the screen. • Alarm tone: Slow beep. • HeartMate Touch App alarm active: Replace System Controller
Alarm means:	An internal malfunction in the System Controller has occurred that requires clinician diagnosis and resolution.
To resolve alarm:	<p>Patients must call their hospital contact immediately for diagnosis and instructions. Switch to the backup System Controller if instructed to do so.</p> <p>Clinicians should:</p> <ol style="list-style-type: none"> 1. Switch to the backup System Controller. 2. Provide patient with a new System Controller.
Alarm silence period:	<ul style="list-style-type: none"> • 4 hours or until any new alarm occurs. • To silence this alarm, press the silence alarm button ().

Table 7.14 System Controller Fault Alarm

IMPORTANT! A backup System Controller is identical to the running System Controller and is programmed with identical patient-specific settings. It should remain with the patient at all times for easy access in an emergency. See *The Backup System Controller* on page 2-45 for details about the backup System Controller, including replacement instructions. See page 2-54.

IMPORTANT! The System Controller will not display all alarms. Certain alarms will be displayed on the HeartMate Touch App only.

Communications Fault (Comm Fault) Alarm



This is an Advisory alarm	
The screen looks like this:	
Behavior and appearance:	<ul style="list-style-type: none"> • Flashing yellow wrench () on the user interface. • “Call Hospital Contact; Comm Fault” on the screen. • Alarm tone: Slow beep. • HeartMate Touch App alarm active: Communication Fault
Alarm means:	<ul style="list-style-type: none"> • The data transfer between the LVAD and the System Controller has been lost. <p>OR</p> <ul style="list-style-type: none"> • The primary and back-up communication wires in the Driveline are not functioning.
To resolve alarm:	<p>Patients must call their hospital contact immediately for diagnosis and instructions.</p> <p>Clinicians should:</p> <ol style="list-style-type: none"> 1. Contact Abbott to determine best next steps. 2. Use the HeartMate Touch App to silence the alarm while awaiting resolution, if needed.
Alarm silence period:	<ul style="list-style-type: none"> • 4 hours or until any new alarm occurs. • To silence this alarm, press the silence alarm button (). • Or - 24 hours if EXTENDED ALARM RESET is selected from the HeartMate Touch App. This selection should only be made while the patient is under supervised medical care. See <i>Extended Alarm Silence</i> on page 4-43. <p>Note: If EXTENDED ALARM RESET is selected, the System Controller will no longer display this alarm. The visual alarm on the HeartMate Touch App is maintained.</p>

Table 7.15 Communication Fault Alarm

System Controller Backup Battery Fault Alarm



This is an Advisory alarm	
The screen looks like this:	
Behavior and appearance:	<ul style="list-style-type: none"> • Flashing yellow wrench () on the user interface. • “Call Hospital Contact; Backup Battery Fault” on the screen. • Alarm tone: Slow beep. • HeartMate Touch App alarm active: Replace Backup Battery
Alarm means:	<p>1. The System Controller’s 11 Volt Lithium-Ion backup battery is compromised.</p> <p>OR</p> <p>2. It is unable to fully support pump function.</p> <p>OR</p> <p>3. There is an issue that requires clinician diagnosis and resolution.</p>
To resolve alarm:	<p>Patients must call their hospital contact immediately for diagnosis and instructions.</p> <p>Clinicians should replace the System Controller 11 Volt Lithium-Ion backup battery. See page 2-40.</p> <p>Note: In most cases, replacing the battery will resolve the alarm. However, it may be necessary to replace the System Controller, or additional steps may be required for resolution. Call Abbott with questions.</p>
Alarm silence period:	<ul style="list-style-type: none"> • 4 hours or until any new alarm occurs. • To silence this alarm, press the silence alarm button ().

Table 7.16 System Controller Backup Battery Fault Alarm

IMPORTANT! The System Controller will not display all alarms. Certain alarms will be displayed on the HeartMate Touch App only.

System Controller Backup Battery Not Installed Alarm



This is an Advisory alarm	
<p>The screens look like this:</p> <p>(alternating screens)</p>	
<p>Behavior and appearance:</p>	<ul style="list-style-type: none"> • Flashing yellow wrench () on the user interface. • “Call Hospital Contact; Backup Battery Fault” and “install battery” graphic alternate on the screen. • Alarm tone: Slow beep. • HeartMate Touch App alarm active: Backup Battery Not Installed
<p>Alarm means:</p>	<ol style="list-style-type: none"> 1. The System Controller’s 11 Volt Lithium-Ion backup battery is not installed. <p>OR</p> <ol style="list-style-type: none"> 2. It is installed incorrectly.
<p>To resolve alarm:</p>	<p>Patients must call their hospital contact immediately for diagnosis and instructions.</p> <p>Clinicians should:</p> <ol style="list-style-type: none"> 1. Install the 11 Volt Lithium-Ion backup battery in the System Controller (see <i>Replacing a Backup Battery in the System Controller</i> on page 2-40). 2. Obtain a new 11 Volt Lithium-Ion backup battery replacement kit. <p>Note: In most cases, installing the battery will resolve the alarm. However, it may be necessary to replace the System Controller, or additional steps may be required for resolution. Call Abbott with questions.</p>
<p>Alarm silence period:</p>	<ul style="list-style-type: none"> • 4 hours or until any new alarm occurs. • To silence this alarm, press the silence alarm button ().

Table 7.17 System Controller Backup Battery Not Installed Alarm

Driveline Power Fault Alarm

This is an Advisory alarm	
The screen looks like this:	
Behavior and appearance:	<ul style="list-style-type: none"> • Flashing yellow wrench (🔧) on the user interface. • “Call Hospital Contact; Driveline Power Fault” on the screen. • Alarm tone: Slow beep. • HeartMate Touch App alarm active: Driveline Power Fault
Alarm means:	One of the redundant power handling wires inside the Driveline may be damaged or broken.
To resolve alarm:	<p>Patients must call their hospital contact immediately for diagnosis and instructions.</p> <p>Clinicians should:</p> <ol style="list-style-type: none"> 1. Contact Abbott to determine best next steps. 2. Use the HeartMate Touch App to silence the alarm while awaiting resolution, if needed. <p>Note: The alarm must be active in order to access the alarm silence for this situation.</p>
Alarm silence period:	<ul style="list-style-type: none"> • 4 hours or until any new alarm occurs. • To silence this alarm, press the silence alarm button (🔇). • In addition, it can be permanently silenced and cleared for troubleshooting purposes, but only by clinicians through the HeartMate Touch App and when it is the only active alarm (or in conjunction with Driveline Communication Fault and/or LVAD Fault). See <i>Alarm Status Bar</i> on page 4-40. • If this alarm condition is permanently silenced, it will no longer appear on the System Controller LCD screen. The HeartMate Touch App will maintain a visual alarm.

Table 7.18 Driveline Power Fault Alarm

Driveline Communication Fault (Driveline Comm Fault) Alarm



This is an Advisory alarm	
The screen looks like this:	
Behavior and appearance:	<ul style="list-style-type: none"> • Flashing yellow wrench () on the user interface. • “Call Hospital Contact; Driveline Comm Fault” on the screen. • Alarm tone: Slow beep. • HeartMate Touch App alarm active: Driveline Communication Fault
Alarm means:	One of the redundant communication wires inside the Driveline may be damaged or broken.
To resolve alarm:	<p>Patients must call their hospital contact immediately for diagnosis and instructions.</p> <p>Clinicians should:</p> <ol style="list-style-type: none"> 1. Contact Abbott to determine best next steps. 2. Use the HeartMate Touch App to silence the alarm while awaiting resolution, if needed. <p>Note: The alarm must be active in order to access the alarm silence for this situation.</p>
Alarm silence period:	<ul style="list-style-type: none"> • 4 hours or until any new alarm occurs. • To silence this alarm, press the silence alarm button (). • In addition, it can be permanently silenced and cleared for troubleshooting purposes, but only by clinicians through the HeartMate Touch App and when it is the only active alarm (or in conjunction with Driveline Power Fault and/or LVAD Fault). See page 4-48. • If this alarm condition is permanently silenced, it will no longer appear on the System Controller LCD screen. The HeartMate Touch App will maintain a visual alarm.

Table 7.19 Driveline Communication Fault Alarm

HeartMate Touch™ App Alarms

Certain Advisory alarms only appear on the HeartMate Touch™ App: Low Speed Advisory, LVAD Fault, and Controller Clock Not Set. A text banner appears; however, there is no audible alarm.



Priority	HeartMate Touch App	To Resolve Alarm
A D V I S O R Y		<ol style="list-style-type: none"> 1. Use the HeartMate Touch App to check that the fixed speed and low speed limit have been appropriately set. 2. Replace the System Controller. 3. Clinically evaluate the patient. <p>See page 7-26.</p>
	<p>Warning: Low Speed Advisory</p> 	<p>Use the HeartMate Touch App to silence the alarm while awaiting resolution, if needed.</p> <p>Note: The alarm must be active in order to access the alarm silence for this situation.</p> <p>See page 7-27.</p>
	<p>LVAD Fault</p> 	<p>Use the HeartMate Touch App to set the System Controller's internal clock.</p> <p>See page 7-28.</p>
	<p>Controller Clock Not Set</p>	

Table 7.20 HeartMate Touch™ App Advisory Alarms

Low Speed Advisory - HeartMate Touch App

This is an Advisory alarm	
HeartMate Touch App view:	
Behavior and appearance:	HeartMate Touch App alarm active: Low Speed Advisory
Alarm means:	Either the fixed speed has been set 200 rpm or more below the low speed limit or the System Controller is unable to maintain the speed at or above the low speed limit.
To resolve alarm:	<p>Clinicians should:</p> <ol style="list-style-type: none"> 1. Use the HeartMate Touch App to check that the fixed speed and low speed limit have been appropriately set. 2. Replace the System Controller. See page 2-54. 3. Clinically evaluate the patient.
Alarm silence period:	The Silence Alarm button will appear for this alarm condition. In this case, the button will not perform any function.

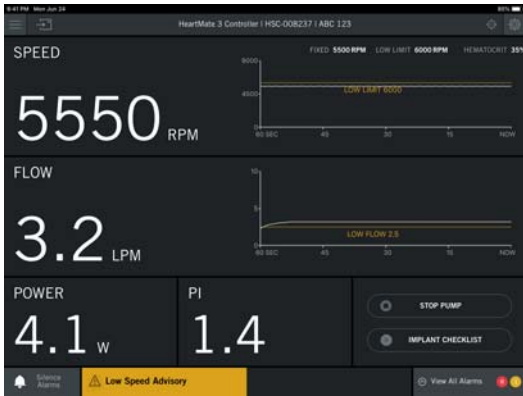
Table 7.21 Low Speed Advisory Alarm

LVAD Fault - HeartMate Touch App

This is an Advisory alarm	
HeartMate Touch App view:	
Behavior and appearance:	HeartMate Touch App alarm active: LVAD Fault
Alarm means:	The LVAD has determined that one or more internal LVAD operating conditions are out of range.
To resolve alarm:	<p>Patients must call their hospital contact immediately for diagnosis and instructions.</p> <p>Clinicians should:</p> <ol style="list-style-type: none"> 1. Contact Abbott to determine best next steps. 2. Use the HeartMate Touch App to silence the alarm while awaiting resolution, if needed.
Alarm silence period:	The Silence Alarm button will appear for this alarm condition. In this case, the button will not perform any function.

Table 7.22 LVAD Fault Alarm

Controller Clock Not Set - HeartMate Touch App

This is an Advisory alarm	
HeartMate Touch App view:	
Behavior and appearance:	HeartMate Touch App alarm active: Controller Clock Not Set
Alarm means:	The System Controller’s internal clock needs to be set. Installing a new 11 Volt Lithium-Ion backup battery in the System Controller may prompt this alarm.
To resolve alarm:	Clinicians should use the HeartMate Touch App to set the System Controller’s internal clock (See <i>Controller Date & Time</i> on page 4-33). Note: Be sure the Tablet clock is correct.
Alarm silence period:	The Silence Alarm button will appear for this alarm condition. In this case, the button will not perform any function.

Table 7.23 Controller Clock Not Set Alarm

Wireless Connection Lost - HeartMate Touch App



Notification	
The HeartMate Touch App message:	
HeartMate Touch Wireless Adapter Status:	<p>Light is off.</p> 
Behavior and appearance:	<p>HeartMate Touch App notification: Connection lost to a Wireless Device. No audible alarms.</p>
Notification means:	<p>The Tablet for use with the HeartMate Touch App is no longer wirelessly communicating with the HeartMate Touch Wireless Adapter.</p>
To resolve notification:	<p>Clinicians should use the HeartMate Touch App to reconnect to the HeartMate Touch Wireless Adapter.</p> <ol style="list-style-type: none"> 1. Tap RESTART. 2. Press and hold the button on the HeartMate Touch Wireless Adapter for 3 seconds to turn on Bluetooth® wireless technology. A blinking blue light appears. 3. Use the HeartMate Touch App to connect to the HeartMate Touch Wireless Adapter. <p>Note: Be sure the Tablet clock is correct.</p>

Table 7.24 Wireless Connection Lost

Disconnected System Controller - HeartMate Touch App

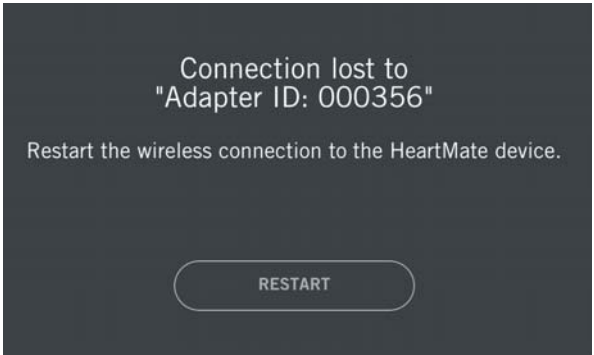

Notification	
The HeartMate Touch App message:	
HeartMate Touch Wireless Adapter Status:	<p>Solid blue light.</p> 
Behavior and appearance:	HeartMate Touch App notification: Connection lost to a System Controller. No audible alarms.
Notification means:	The HeartMate Touch Communication System is no longer communicating with the System Controller.
To resolve notification:	<ol style="list-style-type: none"> 1. Tap END SESSION. 2. Check that the System Controller is fully connected. 3. Tap CONTINUE.

Table 7.25 Disconnected System Controller Notification

Connection Failed - HeartMate Touch App

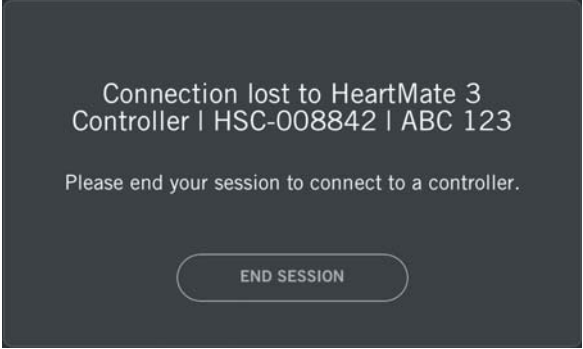

Notification	
The HeartMate Touch App message:	
HeartMate Touch Wireless Adapter Status:	<p>Light is off or blinking.</p> 
Behavior and appearance:	HeartMate Touch App notification: Connection failed. No audible alarms.
Notification means:	The HeartMate Touch App connection to the HeartMate Touch Wireless Adapter has failed.
To resolve notification:	<ol style="list-style-type: none"> 1. Tap RETRY. 2. Quit and restart the HeartMate Touch App. 3. Remove the HeartMate Touch Wireless Adapter from the Power Module. 4. Re-insert the HeartMate Touch Wireless Adapter into the Power Module. 5. Press and hold the button on the HeartMate Touch Wireless Adapter for 3 seconds to turn on Bluetooth® wireless technology. A blinking blue light appears. 6. Use the HeartMate Touch App to connect to the HeartMate Touch Wireless Adapter.

Table 7.26 Connection Failed Notification

Communication Lost to Adapter - HeartMate Touch App

Notification	
The HeartMate Touch App message:	
HeartMate Touch Wireless Adapter Status:	<p>Blinking blue light.</p> 
Behavior and appearance:	<p>HeartMate Touch App notification: Communication lost to "Adapter ID: 123456"...Reconnecting. No audible alarms.</p>
Notification means:	<p>The HeartMate Touch App is attempting to reconnect to the HeartMate Touch Wireless Adapter.</p> <p>Note: During the reconnection process, the LVAD will continue to operate at its current settings.</p>
To resolve notification:	<p>No action required. It may take 30 seconds to reconnect the HeartMate Touch App to the HeartMate Touch Wireless Adapter.</p> <p>The blinking blue light indicates that the HeartMate Touch Wireless Adapter is ready to reconnect to the HeartMate Touch App.</p>

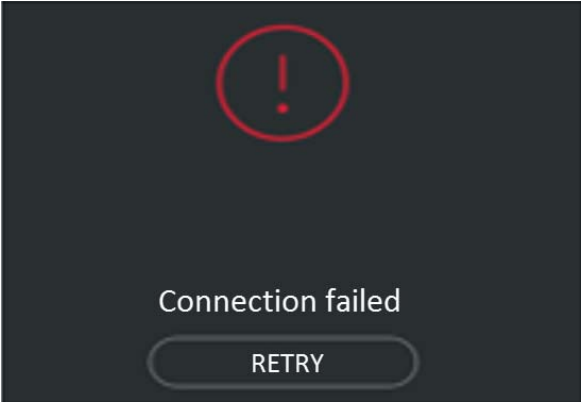
Table 7.27 Communication Lost to Adapter

Other Troubleshooting Basics

If you experience any of these issues, review the troubleshooting guide below.

Issues

The HeartMate Touch App shuts down.

*The System Controller is not detected on the wireless connection screen. **CONTINUE** is grey and you cannot confirm the HeartMate Touch Wireless Adapter number.*

The HeartMate Touch App freezes.

*A **Connection failed** message appears when connecting.*

Resolution

1. Quit the HeartMate Touch App.
 - a. Double-click the Home button to show your most recently used apps.
 - b. Swipe right or left to find the app that you want to close.
 - c. Swipe up on the app's preview to close the app.
2. Gently pull the HeartMate Touch Wireless Adapter from the Power Module socket.
3. Insert the HeartMate Touch Wireless Adapter back in to the Power Module socket.
4. Restart the App and connect the HeartMate Touch Wireless Adapter to the Tablet for use with the HeartMate Touch App.

If the issue is not resolved with the above steps, perform the steps below:

5. Press and hold the Top (or Side) button until the power off slider appears.
6. Drag the slider to turn your device completely off.
7. After your device turns off, press and hold the Top (or Side) button again until you see the Apple logo.
8. Once device turns on, perform steps 2-4 above.

Issue

*The System Controller is not detected on the wireless connection screen. **CONTINUE** is grey and you cannot confirm the HeartMate Touch Wireless Adapter number.*

Resolution

1. Make sure the System Controller power cables are securely connected to the Power Module patient cable.
2. Make sure the Power Module patient cable is connected to the Power Module.

If the System Controller is securely connected:

1. Quit the HeartMate Touch App.
 - a. Double-click the Home button to show your most recently used apps.
 - b. Swipe right or left to find the app that you want to close.
 - c. Swipe up on the app's preview to close the app.
2. Gently pull the HeartMate Touch Wireless Adapter from the Power Module socket.
3. Insert the HeartMate Touch Wireless Adapter back in to the Power Module socket.
4. Restart the App and connect the HeartMate Touch Wireless Adapter to the Tablet for use with the HeartMate Touch App.

If the issue is not resolved with the above steps, perform the steps below:

5. Press and hold the Top (or Side) button until the power off slider appears.
6. Drag the slider to turn your device completely off.
7. After your device turns off, press and hold the Top (or Side) button again until you see the Apple logo.
8. Once device turns on, perform steps 2-4 above.

Issue

The HeartMate Touch App does not detect the HeartMate Touch Wireless Adapter ID number - even when the HeartMate Touch Wireless Adapter is ready to connect. (HeartMate Touch Wireless Adapter is illuminating a blinking blue light.)

Resolution

1. Tap **Refresh** ().
2. On the Tablet, go to **Settings > Bluetooth** and make sure that Bluetooth is on.

Issue

Tablet clock is incorrect.

Resolution

1. On the Tablet, go to **Settings > General > Date & Time**.
2. Visit www.apple.com to get help with the date and time on your Tablet.

Issue

HeartMate Touch App cannot be updated.

Resolution

1. Quit the HeartMate Touch App.
2. Please contact Abbott for assistance.

Issue

The HeartMate Touch Wireless Adapter does not illuminate a blinking blue light even though the following conditions for set up and connection have been met. (See Set Up the HeartMate Touch™ Communication System on page 4-7.)

- The Power Module is set up and powered on.
- The HeartMate Touch Wireless Adapter has been inserted into the socket located on the side of the Power Module.
- The Tablet is on.
- The HeartMate Touch App has been launched.

Resolution

1. Gently pull the HeartMate Touch Wireless Adapter from the Power Module socket.
2. Insert the HeartMate Touch Wireless Adapter back in to the Power Module socket.
3. Ensure that the HeartMate Touch Wireless Adapter is fully connected to the Power Module socket.
4. Press and hold the button on the HeartMate Touch Wireless Adapter for more than 3 seconds.
5. If the issue persists, replace the HeartMate Touch Wireless Adapter.

Handling Power Module Alarms

The Power Module's internal computer continually monitors Power Module performance. The Power Module issues an alert for the following alarm conditions:

- AC Fail
- Advisory LO BATT (low battery)
- Hazard LO BATT (critically low battery)
- Power Module Backup Battery Malfunction

All Power Module alarm conditions are accompanied by a visual indicator (**Figure 7.4**) and audio tone. Different visual and audio indicators are active, depending on the alarm condition. See page 7-38. for a description of Power Module alarms and how to respond to them.

IMPORTANT! If an audio alarm sounds from the Power Module without an accompanying visual indicator illuminating at the same time, please contact Abbott for assistance. For Abbott contact information, see the *Back Cover* of this manual.



Figure 7.4 Alarm Indicators on Front of Power Module

IMPORTANT! The backup battery indicator turns yellow and then red as the internal battery is depleted. When only 5 minutes of power remain, the Power Module audio tone becomes constant and the alarm can no longer be silenced. A red Hazard LO BATT alarm can only be silenced by switching to another power source.





Alarm	Meaning	What You Should Do
<p>AC FAIL Power On indicator changes from green to yellow</p>  <p>accompanied by beeping audio tone</p>	<p>AC power off or disconnected.</p> <p>When new, the Power Module backup battery will power the HeartMate 3™ system for approximately 30 minutes. The Power Module backup battery is not recharged during AC FAIL.</p>	<ol style="list-style-type: none"> 1. Press the Power Module's silence alarm button (⊗) to silence the alarm (it remains silenced indefinitely or until cancelled by another alarm). 2. Promptly switch to a new set of charged batteries.
<p>Advisory LO BATT yellow internal backup battery</p>  <p>indicator accompanied by beeping audio tone</p>	<p>Less than 15 minutes of Power Module backup battery power remain.</p>	<ol style="list-style-type: none"> 1. Press the Power Module's silence alarm button (⊗) to silence the alarm for 8 hours. 2. Promptly switch to a new set of charged batteries.
<p>Hazard LO BATT red internal backup battery</p>  <p>indicator accompanied by continuous audio tone</p>	<p>Less than 5 minutes of Power Module backup battery power remain.</p>	<p>Immediately switch to a new set of charged batteries.</p>
<p>Advisory Fault yellow wrench indicator</p>  <p>accompanied by beeping audio tone</p>	<p>Internal malfunction detected within the Power Module.</p>	<p>Switch to a new set of charged batteries at earliest convenience.</p>
<p>Critical Fault yellow wrench indicator</p>  <p>accompanied by continuous audio tone</p>	<p>Internal malfunction detected within the Power Module.</p>	<p>Immediately switch to a new set of charged batteries.</p>

Table 7.28 Power Module Alarms



Alarm	Meaning	What You Should Do
<p>Critical Fault yellow wrench and red internal backup battery indicators</p>   <p>accompanied by continuous audio tone</p>	<p>The Power Module backup battery is not functioning properly or is not installed.</p>	<p>Immediately switch to a new set of charged HeartMate™ 14 Volt Lithium-Ion batteries.</p>

Table 7.28 Power Module Alarms (Continued)

IMPORTANT! The backup battery indicator turns yellow and then red as the internal battery is depleted. When only 5 minutes of power remain, the Power Module audio tone becomes constant and the alarm can no longer be silenced. A red Hazard LO BATT alarm can only be silenced by switching to another power source.

Mobile Power Unit Alarms

The Mobile Power Unit issues an alarm for the following conditions:

- Replace Mobile Power Unit Batteries
- Mobile Power Unit Internal Malfunction

IMPORTANT! When the Mobile Power Unit is connected to the System Controller, the Mobile Power Unit duplicates any active System Controller alarms. See *Handling System Controller Alarms* on page 7-2.

All Mobile Power Unit alarms are accompanied by an illuminated symbol (**Figure 7.5**) and sound. Different lights and sounds come on, depending on the alarm. See **Table 7.29** for a description of the Mobile Power Unit alarms and how to resolve each alarm.



Figure 7.5 Indicators on the Mobile Power Unit

Note: If there is an alarm for the Mobile Power Unit but no light comes on, please contact Abbott for assistance. For Abbott contact information, see the *Back Cover* of this manual.



Alarm Symbol	Meaning	What You Should Do
 <p>Advisory Alarm Yellow Mobile Power Unit battery indicator with beeping audio tone</p>	<p>Internal AA Mobile Power Unit batteries need to be replaced.</p>	<ol style="list-style-type: none"> 1. Promptly switch to two fully-charged HeartMate™ 14 Volt Lithium-Ion batteries. 2. Replace Mobile Power Unit batteries (see <i>Installing or Replacing the Mobile Power Unit Batteries</i> on page 3-39).
 <p>Advisory Alarm Yellow wrench light with beeping audio tone</p>	<p>Internal malfunction detected within the Mobile Power Unit.</p>	<p>Promptly switch to two fully-charged HeartMate 14 Volt Lithium-Ion batteries.</p>

Table 7.29 Mobile Power Unit Alarms

Using the Charger to Check Battery or Charger Status

The Battery Charger continually monitors its own performance and that of any battery placed into a pocket. Actual or potential problems, or "faults," appear as "advisory messages" on the display panel.

Battery-Related Advisory Messages

If the Battery Charger detects a problem with a battery, such as battery voltage too high or too low, or open battery circuit, the red light for the pocket comes on and a telephone symbol appears on the display panel to indicate a battery fault (**Figure 7.6**).



Figure 7.6 Advisory Display in Graphics Mode. Note Red Light for Pocket 1.

Before assuming that the battery is defective, make sure that the connection between the battery and charging pocket contacts is not blocked by dirt or debris.

TO CONFIRM A BATTERY FAULT:

1. Remove the battery. Examine the battery's metal contact and the contact inside the charging pocket. If there is no dirt, debris, or obstruction, continue to Step 2.
2. Reinsert the battery into the same pocket.
3. If the red light comes on again, insert the battery into a different pocket.
4. If the red light comes on in a second pocket, the battery is defective. Do not use it.
5. Obtain the alarm code for the battery, if possible:
 - a. Press and hold the number button for this pocket. The alarm code appears on the screen. The alarm code is one letter followed by four numbers. Alarm codes related to batteries begin with the letter "B."
 - b. Record the alarm code and save it for future reference.
6. Remove the defective battery from use.

Charger-Related Advisory Messages

The Battery Charger can detect a problem or fault condition in up to four charging pockets at once (with or without batteries inserted), or with the entire charger unit. The charger alerts you immediately of any problems.

Detecting Pocket Faults

When the charger detects a pocket fault, the red light for the affected pocket comes on, with or without a battery inserted in the pocket. In addition, the charger immediately stops charging or calibrating the battery in the affected pocket, if one is present.

TO REPORT A BATTERY CHARGER POCKET FAULT:

1. Remove the battery from the affected pocket, if one is inserted.
2. Record the alarm code for the defective pocket, if possible:
 - a. Press and hold the number button for this pocket. The alarm code appears on the screen. The alarm code is one letter followed by four numbers. Alarm codes related to pocket problems begin with the letter "S."
 - b. Record the alarm code and save it for future reference.

IMPORTANT! Do not use the defective charging pocket until it is repaired or until the Battery Charger is replaced. The pockets that are not defective can still be used.

Detecting Faults with the Entire Charger

If the charger detects a fault with the entire charger, all four red lights come on and all charging and calibrating stops.

TO REPORT A FAULT FOR THE ENTIRE CHARGER:

1. Remove all batteries from all pockets.
2. Record the alarm code for the fault condition, if possible:
 - a. Press and hold the number button for any pocket. The alarm code appears on the screen. The alarm code is one letter followed by four numbers. Alarm codes for the entire charger begin with the letter "S."
 - b. Record the alarm code and save it for future reference.
3. Turn off the charger; unplug it from the electrical outlet.

IMPORTANT! Do not use a damaged or defective Battery Charger until it is repaired or replaced. Until there is a safe and reliable way to recharge batteries, use the HeartMate™ Power Module or Mobile Power Unit to power the HeartMate system.

Battery Charger Display Panel Messages

The English mode always displays first. The following shows the screens to select the mode.

Change Display Mode to English	OK	ENGLISH	▼
Change Display Mode to Graphics	OK	GRAPHICS	▼

KEY for Table

Y	Battery Charger pocket number
# = X	Battery charge cycle count
mAh	milliamp-hour
C	Battery capacity
B0001	Battery fault with alarm code, example
S0001	Battery Charger pocket (slot) fault with alarm code, example

Table 7.30 describes the messages that appear on the Battery Charger display panel.







Meaning	English Mode	Graphics Mode
Ready for Use	HeartMate CHARGER	HeartMate CHARGER
Battery Charge Status	Y: ■■■■■	1:  50%
Battery Information (3rd screen)	# = X X: mAh = C	# = X X: mAh = C
Charge Complete	READY Y: ■■■■■	1: 
Request Calibration	CALIBRATE? PRESS Y	
Accept Calibration	PROGRESS Y: CALIBRATING	1: 
Charger Fault	CALL SERVICE	
Battery Fault (Button Push)	CALL SERVICE B0001	 B 0 0 0 1
Charger or Pocket Fault (Button Push)	CALL SERVICE S0001	 S 0 0 0 1

Table 7.30 Battery Charger Display Panel Messages

Guidelines for Power Cable Connectors

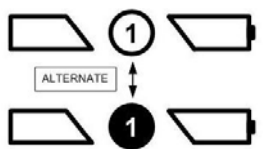
Use care when connecting and disconnecting power cable connectors.

Be sure to:

- Line up the half circles inside the connectors, as shown in **Figure 7.7**.
- Gently bring the connectors together, turning them slightly to make the connection, if needed.
- Never pull, turn, or twist the strain relief portion of the connectors (where the connector and cable meet).
- When you feel the connectors engage, push them together firmly until fully connected, without twisting or forcing the connectors.
- Secure the connection between the connectors by turning the connector nut on the connector (**Figure 7.8**).
- Hand tighten the connector nut; do not use tools. Do not twist the connectors when turning the nut.
- When disconnecting connectors, turn the connector nut on the connector until the connection is loose and then gently pull the connectors apart.
- Never twist connectors or pull them apart at an angle.



Figure 7.7 Align Half Circles

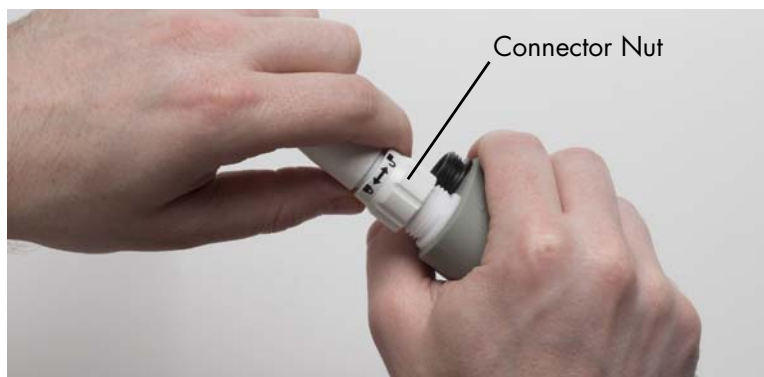

Figure 7.8 Turn Nut on the Connector

What Not To Do: Driveline and Cables

Check the Driveline, System Controller power cables, Power Module patient cable, and Mobile Power Unit patient cable for twisting, kinking, or bending which could cause damage to the wires inside, even if external damage is not visible. Damage to the Driveline or cables could cause the Left Ventricular Assist Device to stop. If the Driveline or cables become twisted, kinked, or bent, carefully unravel and straighten.

CAUTION !

Use care and do not twist, kink, or sharply bend the Driveline.

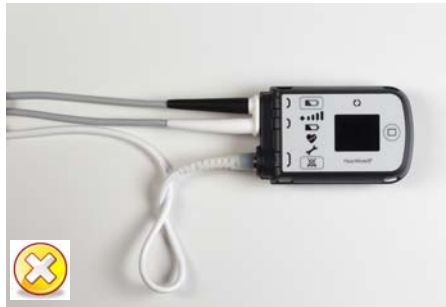

CAUTION !

Use care and do not twist, kink, or sharply bend the System Controller power cables.

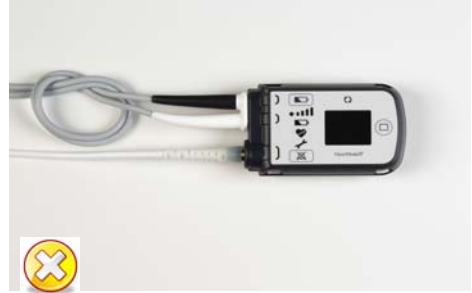
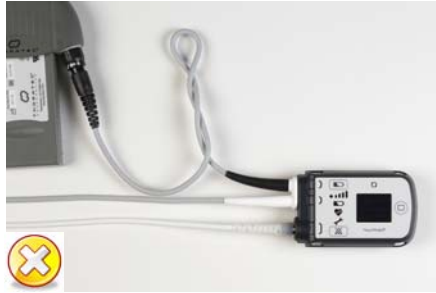

CAUTION !

- Do not twist, kink, or sharply bend the Mobile Power Unit patient cable.
- Route the patient cable so it will not cause a tripping or falling hazard.
- Take care when moving around while connected to the Mobile Power Unit, that it is not inadvertently pulled off of furniture.



CAUTION !

Use care and do not twist, kink, or sharply bend the Power Module patient cable.

WARNING !

Do not connect a System Controller to both the Mobile Power Unit and the Power Module at the same time, or damage to the System Controller and injury to the patient may occur. First connect to HeartMate™ 14 Volt batteries.



Do not insert a misaligned Driveline Cable Connector into the System Controller Driveline Connector. **Align** the WHITE arrow/ alignment mark on the Driveline Cable Connector with the WHITE arrow on the System Controller Driveline Connector.



Do not orient the System Controller so the display is facing up. **Align** the WHITE arrow/ alignment mark on the Driveline Cable Connector with the WHITE arrow on the rear of the System Controller Driveline Connector.



EQUIPMENT STORAGE AND CARE

This section provides information on how to store and care for the HeartMate 3™ Left Ventricular Assist System.

Storage and Transport - - - - -	8-2
Cleaning and Maintenance- - - - -	8-4
Product Disposal - - - - -	-8-11

Storage and Transport

Acceptable Packaged Storage and Transport Conditions

Storing and transporting the equipment outside of the environmental parameters listed below may affect operation or result in equipment failure.

Equipment	Acceptable Temperature Range °F (°C)	Relative Humidity	Air Pressure mm Hg (hPA)
Power Module with Backup Battery	5°F to 104°F (-15°C to 40°C)	10% to 93%	375 to 795 (500 to 1060)
Power Module Patient Cable	5°F to 122°F (-15°C to 50°C)	10% to 93%	375 to 795 (500 to 1060)
Tablet for use with the HeartMate Touch App	-4°F to 113°F (-20°C to 45°C)	5% to 95%	535 to 795 (710 to 1060)
HeartMate Touch Wireless Adapter	5°F to 104°F (-15°C to 40°C)	10% to 93%	375 to 795 (500 to 1060)
Mobile Power Unit	-13°F to 158°F (-25°C to 70°C)	Up to 93%	375 to 795 (500 to 1060)
HeartMate™ 14 Volt Lithium-Ion Batteries	14°F to 104°F (-10°C to 40°C)	10% to 93%	375 to 795 (500 to 1060)
HeartMate 14 Volt Battery Clips	5°F to 104°F (-15°C to 40°C)	10% to 93%	375 to 795 (500 to 1060)
Battery Charger	-4°F to 140°F (-20°C to 60°C)	10% to 93%	375 to 795 (500 to 1060)
System Controller, Backup System Controller	-13°F to 104°F (-25°C to 40°C)	10% to 93%	375 to 795 (500 to 1060)

Table 8.1 Acceptable Environmental Conditions for Storage and Transport

Equipment	Acceptable Temperature Range °F (°C)	Relative Humidity	Air Pressure mm Hg (hPA)
11 Volt Lithium-Ion Backup Battery	-13°F to 104°F (-25°C to 40°C)	10% to 93%	375 to 795 (500 to 1060)
Wear and Carry Accessories, including Shower Bag	-4°F to 131°F (-20°C to 55°C)	20% to 85%	Not applicable

Table 8.1 Acceptable Environmental Conditions for Storage and Transport

Cleaning and Maintenance

Although the HeartMate 3™ Left Ventricular Assist System does not have external moving components and thus requires little planned maintenance, the external components should undergo routine and periodic inspections, cleaning, and maintenance as prescribed in this section.

General Cleaning Guidelines for All Equipment

Use a damp cloth to clean exterior surfaces of the system components, as needed. Water, with or without a mild dish soap, may be used as a surface cleaner.

WARNING !

- Do not allow water to penetrate into the interior of the equipment.
- Do not immerse equipment in water or liquid. Immersion in water or liquid may cause the Pump to stop.

Cleaning the System Controller

As needed, clean exterior surfaces of the System Controller with a damp, lint-free cloth. If more aggressive cleaning is needed, use warm water and a mild dish soap.

WARNING !

Never submerge the System Controller into water or liquid. Submersion in water or liquid may cause the Pump to stop.

Periodically inspect the System Controller's power connector pins for dirt or grease. If you find damage, dirt, or contamination on the pins, do not attempt to clean the pins yourself. Report the condition to Abbott. Cleaning and service for the System Controller's power connector pins should be performed only by authorized technicians trained by Abbott.

Periodically inspect the System Controller's audio speakers for dirt or grease. If you notice a change in tone or in loudness during a System Controller self test, the audio speaker sockets may be obstructed. Audio speaker sockets may be cleaned using a small cotton swab that is moistened (not dripping) with rubbing alcohol. Never insert anything sharp (such as a toothpick or pin) into the audio speaker sockets.

CAUTION !

Inserting a sharp object into the System Controller audio socket may damage the speakers inside.

WARNING !

Do not disconnect the System Controller from the Driveline for cleaning. Disconnecting the Driveline from the System Controller will cause the Pump to stop. The System Controller Driveline connector should be disconnected only when replacing the System Controller. Refer to *The Backup System Controller* on page 2-45.

Cleaning System Controller Power Cables

As needed, clean exterior surfaces of the System Controller power cables with a damp, lint-free cloth. If more aggressive cleaning is needed, use warm water and mild dish soap. Keep the System Controller power cables dry and away from water or liquid. If the System Controller power cables come into contact with water or liquid, the system may fail to operate properly or you may get a serious electric shock.

Care of the Driveline

Damage due to wear and fatigue of the Driveline has occurred in both the externalized and implanted portions of the Driveline of commercially available implantable LVADs. Damage to the redundant wires within the Driveline may or may not be preceded by visible damage to the outer layer of the Driveline.

Driveline damage may be evidenced by the following:

- Driveline faults may occur on Battery or Power Module operation.
- Transient alarms due to short or open circuits, often associated with movement of the patient or the Driveline.
- High pump power associated with reduced pump speed, as recorded in the System Controller event log file.
- High pulsatility index (PI) and/or the need for frequent replacement of the System Controller.
- Feelings of pump vibrations.
- Fluid leakage from the external portion of the Driveline.
- Cessation of pumping.

If you suspect a damaged Driveline, please contact Abbott for assistance. See Abbott contact information on the *Back Cover* of this manual.

X-ray images may be useful to assess the extent and location of the Driveline damage. If damage to the electrical conductors in the Driveline is confirmed, the Left Ventricular Assist Device should be replaced as soon as possible.

A disruption to the continuity of the wires in the Driveline may cause damage to the System Controller. If damage to the System Controller occurs and the System Controller requires replacement, consider supporting the patient using batteries to reduce the potential of further damage to the System Controller.

Cleaning the Driveline

As needed, clean exterior surfaces of the Driveline cables with a damp, lint-free cloth. If more aggressive cleaning is needed, use warm water and mild dish soap.

Caring for the Power Module and Mobile Power Unit

Inspect the HeartMate™ Power Module and the Mobile Power Unit routinely as described in *Safety Checklists* on page F-1 for the safest and best possible performance.

IMPORTANT! Do not disconnect the System Controller from the Driveline. This connection should be inspected only when replacing the System Controller (see *Replacing the Current System Controller* on page 2-54).

Cleaning the Power Module and Mobile Power Unit

Periodically, and as needed, unplug the Power Module and Mobile Power Unit and clean the exterior surfaces using a clean, damp (not wet) cloth. You may use a mild detergent, if necessary. Keep the Power Module and Mobile Power Unit dry and away from water or liquid. If the Power Module or Mobile Power Unit comes into contact with water or liquid, it may fail to operate properly or you may get an electric shock. Do not clean the Power Module or Mobile Power Unit while it is being used to power the Left Ventricular Assist System.

If the Mobile Power Unit is left in storage for a long period of time with the batteries installed, the alkaline batteries may corrode. If corrosion is observed, report the condition to Abbott. For Abbott contact information, see the *Back Cover* of this manual.

Cleaning and service should be performed only by Abbott-trained personnel. Do not attempt to clean or repair equipment on your own. Thoroughly wash any areas where contact with corroded batteries is made.

IMPORTANT! Ensure that the Power Module backup battery is reconnected after service or shipping (see *Reconnecting the Power Module Backup Battery* on page 3-30).

Cleaning HeartMate™ 14 Volt Lithium-Ion Batteries and Battery Clips

HeartMate batteries require periodic inspection and cleaning to ensure the best possible performance. Follow the guidelines and instructions in the *Safety Checklists* on page F-1.

Clean the metal battery contacts and the interior contacts of battery clips monthly using a cotton swab or lint-free cloth that has been moistened (not dripping) with rubbing alcohol. Allow the alcohol to dry before using newly cleaned batteries or clips. Do not clean batteries while the batteries are in use. See **Figure 8.1**.



Figure 8.1 Clean the Battery Contacts and Clips

Cleaning the Battery Charger

The Battery Charger requires little maintenance. However, it should be inspected routinely for the safest and best possible performance. For more information, see the *Safety Checklists* on page F-1.

Cleaning HeartMate™ Wear and Carry Accessories

HeartMate™ wear and carry accessories are designed to securely hold or protect HeartMate 3 components. The accessories include:

- Shower Bag
- Consolidated Bag
- System Controller Neck Strap
- Belt attachment
- Holster vest
- Battery holster
- Protection Bag
- Travel Bag

Keep the wear and carry accessories clean to help them work properly. If an accessory gets dirty, wash it by hand using mild detergent, a medium-bristle brush, and cold water. Never use a washing machine to wash a wear and carry accessory. Hang the accessory to drip dry. Always allow it to air dry on its own. Never use a clothes dryer or hair dryer to dry a wear and carry accessory.

Mechanical washers and heated dryers can damage the accessories. Make sure an accessory is completely dry before using it—this includes the Shower Bag.

Periodically inspect the wear and carry accessories for damage or wear. If an accessory appears damaged or worn, do not use it. Contact Abbott with questions or to order a replacement, if needed.

Cleaning the Tablet

The Tablet that is deployed with the HeartMate Touch App serves as the display screen. A protective case protects the Tablet.

Note: Battery life varies by use and configuration; see www.apple.com/batteries for more information. The Tablet should be charged sufficiently and connected to AC power prior to use.

Before cleaning the Tablet:

- Unplug all cables, Abbott approved Flash Drives, and any other accessories.
- Turn off the Tablet (Press and hold the top button until the slider appears, then drag the slider.)

When cleaning the Tablet:

- Use a soft lint-free cloth slightly damp with isopropyl alcohol or alcohol-based disposable wipes for cleaning and disinfection.
- Do not oversaturate the cloth and avoid spraying isopropyl alcohol directly on the screen.
- Do not allow moisture into any openings.
- Do not use bleach when cleaning the Tablet.

The Tablet for use with the HeartMate Touch App screen has an oleophobic coating for resistance to fingerprints, smudge marks, and scratches. To maintain the integrity of this coating, avoid using the following items or chemical ingredients:

- Abrasive Cloths, Towels, Paper Towels, and similar abrasive items.
- Window cleaners, house hold cleaners, solvents, bleach (NaClO, 6%), or ammonia (NH₃, 10%).
- Cleaners containing nitric acid (HNO₃, 10%), hydrogen peroxide (H₂O₂, 3%), or sodium hydroxide (NaOH, 10%).
- Abrasives, compressed air, aerosol sprays, and any other solvent.

Cleaning the HeartMate Touch Wireless Adapter

Periodically, and as needed, unplug the HeartMate Touch Wireless Adapter from the Power Module and clean the exterior surfaces using a clean, damp (not wet) cloth. You may use a mild detergent, if necessary. Keep the HeartMate Touch Wireless Adapter dry and away from water or liquid. If the HeartMate Touch Wireless Adapter comes into contact with water or liquid, it may fail to operate properly or you may get an electric shock. Do not clean the HeartMate Touch Wireless Adapter while it is connected to a Power Module.

Cleaning and service should be performed only by Abbott-trained personnel. Do not attempt to clean or repair equipment on you own.

Product Disposal

Specific product disposal considerations for certain HeartMate™ equipment appear below. Otherwise, dispose of all expired or damaged equipment according to applicable local, state, and federal regulations. For additional product disposal information, please contact Abbott for assistance. See Abbott contact information on the *Back Cover* of this manual.

Batteries

HeartMate 14 Volt Lithium-Ion batteries do not contain lead. Dispose of or recycle HeartMate 14 Volt batteries in compliance with all applicable local, state, and federal regulations. Do not incinerate.

The Power Module backup battery and 11 Volt Lithium-Ion backup battery contain lead. Dispose of the Power Module backup battery and 11 Volt Lithium-Ion backup battery in compliance with all applicable local, state, and federal regulations. Never incinerate the discarded Power Module backup battery or 11 Volt Lithium-Ion backup battery.

Power Module

Dispose of or recycle Power Module and Power Module electronics in compliance with all applicable local, state, and federal regulations.

Mobile Power Unit

Dispose of or recycle Mobile Power Unit and Mobile Power Unit electronics in compliance with all applicable local, state, and federal regulations.

Battery Charger

Dispose of or recycle the Battery Charger and Battery Charger electronics in compliance with all applicable local, state, and federal regulations.

Tablet for use with the HeartMate Touch App

The Tablet for use with the HeartMate Touch App contains a Lithium-Ion battery (non-serviceable). Dispose of or recycle the Tablet in compliance with all applicable local, state, and federal regulations.

Note: Follow battery storage instructions detailed on the Apple® website – visit www.apple.com/batteries/maximizing-performance for more information.

HeartMate Touch Wireless Adapter

Dispose of or recycle the HeartMate Touch Wireless Adapter and HeartMate Touch Wireless Adapter electronics in compliance with all applicable local, state, and federal regulations.

SUMMARY OF THE CLINICAL STUDY

This section contains a summary of the HeartMate 3 Left Ventricular Assist System clinical study.

The MOMENTUM 3 trial was a prospective, multicenter, randomized trial comparing the HeartMate 3 LVAS with the HeartMate II LVAS. Patients were enrolled under a single set of entry criteria, irrespective of the intended use of the device as short-term (e.g., bridge to transplant [BTT] and bridge to cardiac recovery) or as long-term (e.g., destination therapy [DT]) support, and were randomized in a 1:1 ratio to either HeartMate 3 or HeartMate II. The trial consisted of three pre-specified cohorts as follows:

- A Short Term (ST) Cohort to establish the safety and effectiveness of the HeartMate 3 LVAS in providing short-term hemodynamic support.
- A Long Term (LT) Cohort, which included ongoing ST Cohort subjects, to establish the safety and effectiveness of the HeartMate 3 LVAS in providing long-term hemodynamic support.
- A Long Term Durability Cohort to establish the long-term clinical durability of the HeartMate 3 LVAD.

Study Design

Short Term (ST) Cohort

Patients in the MOMENTUM 3 ST Cohort were treated between September 2014 and October 2015. The data reflected in this cohort was collected through the 6 month follow-up visit and included 294 patients enrolled at 47 investigational sites. The Summary Results of the Short Term Cohort are presented on page A-5 through page A-27.

Long Term (LT) Cohort

Patients in the MOMENTUM 3 LT Cohort were treated between September 2014 and November 2015. The data reflected in this cohort was collected through the 24 month follow-up visit (November 16, 2017) and included 366 subjects at 52 investigational sites. The Summary Results of the Long Term Cohort are presented on page A-28 through page A-61.

Study Oversight

The MOMENTUM 3 trial was conducted under the oversight of several independent committees, including a Study Oversight Committee, which provided general trial oversight and leadership; a Clinical Events Committee (CEC), which adjudicated all adverse events per pre-established definitions; and a Data and Safety Monitoring Board (DSMB), which reviewed the trial data periodically to ensure that continuation of the trial did not present any unacceptable risk to the patients.

Clinical Inclusion and Exclusion Criteria

Enrollment in the MOMENTUM 3 trial was limited to patients who met the following inclusion criteria:

- Patient or legal representative has signed Informed Consent Form.
- Age ≥ 18 years.
- Body Surface Area (BSA) ≥ 1.2 m².
- New York Heart Association (NYHA) Class III with dyspnea upon mild physical activity or NYHA Class IV
- Left Ventricular Ejection Fraction (LVEF) $\leq 25\%$.
- Inotrope dependent or cardiac index (CI) < 2.2 L/min/m², while not on inotropes and patient must also meet one of the following:
 - On optimal medical management (OMM), based on current heart failure practice guidelines for at least 45 out of the last 60 days and are failing to respond.
 - Advanced heart failure for at least 14 days AND dependent on intra-aortic balloon pump (IABP) for at least 7 days.
- Females of child-bearing age must agree to use adequate contraception.

Patients were not permitted to enroll in the MOMENTUM 3 trial if they met any of the following exclusion criteria:

- Etiology of heart failure due to or associated with uncorrected thyroid disease, obstructive cardiomyopathy, pericardial disease, amyloidosis, or restrictive cardiomyopathy.
- Technical obstacles which pose an inordinately high surgical risk, in the judgment of the investigator.
- Existence of ongoing MCS other than IABP.
- Positive pregnancy test.
- Presence of a mechanical aortic cardiac valve that will not be either converted to a bioprosthesis or oversewn at the time of LVAD implant.
- History of any organ transplant.
- Platelet count $< 100,000 \times 10^3/L$ ($< 100,000/ml$).
- Psychiatric disease/disorder, irreversible cognitive dysfunction or psychosocial issues that are likely to impair compliance with the study protocol and LVAS management.
- History of confirmed, untreated abdominal aortic aneurysm (AAA) > 5 cm in diameter within 6 months of enrollment.
- Presence of an active, uncontrolled infection.
- Intolerance to anticoagulant or antiplatelet therapies or any other peri/post-operative therapy that the investigator will require based upon the patient's health status.
- Presence of any one of the following risk factors for indications of severe end organ dysfunction or failure:

- An international normalized ratio (INR) ≥ 2.0 not due to anticoagulation therapy.
 - Total bilirubin $>43 \mu\text{mol/L}$ (2.5 mg/dl), shock liver, or biopsy proven liver cirrhosis.
 - History of severe chronic obstructive pulmonary disease (COPD) defined as the ratio of forced expiratory volume in one second to forced vital capacity (FEV1/FVC) <0.7 , and FEV1 $<50\%$ predicted.
 - Fixed pulmonary hypertension with a most recent pulmonary vascular resistance (PVR) ≥ 8 Wood units that is unresponsive to pharmacologic intervention.
 - History of stroke within 90 days prior to enrollment, or a history of cerebrovascular disease with significant ($>80\%$) uncorrected carotid artery stenosis.
 - Serum Creatinine $\geq 221 \mu\text{mol/L}$ (2.5 mg/dl) or the need for chronic renal replacement therapy.
 - Significant peripheral vascular disease (PVD) accompanied by rest pain or extremity ulceration.
- Patient has moderate to severe aortic insufficiency without plans for correction during pump implant.
 - Pre albumin $<150 \text{ mg/L}$ (15mg/dL) or Albumin $<30\text{g/L}$ (3 g/dL) (if only one available); pre albumin $<150 \text{ mg/L}$ (15mg/dL) and Albumin $<30\text{g/L}$ (3 g/dL) (if both available).
 - Planned Bi-VAD support prior to enrollment.
 - Patient has known hypo- or hyper-coagulable state such as disseminated intravascular coagulation and heparin induced thrombocytopenia (HIT)
 - Participation in any other clinical investigation that is likely to confound study results or affect the study.
 - Any condition other than heart failure that could limit survival to less than 24 months.

Follow-up Schedule

All patients were scheduled for follow-up examinations at Day 1, 1 week, discharge, 1 month, 3 months, 6 months, 12 months, 18 months and 24 months, postoperatively. Follow-up to support the ST indication was concluded at 6 months.

Preoperative baseline assessments included physical exam, patient demographics, blood chemistry, hemodynamics, medical and cardiac history, current medications, imaging tests, functional capacity as measured by the 6-minute walk test (6MWT) and NYHA classification, and quality of life as measured by EuroQoL 5D-5L (EQ-5D-5L) and Kansas City Cardiomyopathy Questionnaire (KCCQ). Postoperative assessments included current medications, patient status and outcome, blood chemistry, hemodynamics, imaging tests, functional status and quality of life. Pre-defined adverse events, reoperations, readmissions to the hospital and device malfunctions were reported as they occurred.

Short Term Clinical Outcomes

Clinical Endpoints of Short Term Cohort

The primary endpoint for the ST Cohort of the MOMENTUM 3 trial was a composite of survival to transplant, recovery, or 6 months of LVAD support free of debilitating stroke or reoperation to replace the pump. Debilitating stroke was defined as a stroke with Modified Rankin Scale (MRS) >3 assessed at 60 days after the event.

The primary analysis was performed as intent to treat (ITT) and was performed at exactly 180 days. Patients were considered a success if within 180 days post implantation, they receive a cardiac transplant that was not urgently required due to a device malfunction, had the device explanted subsequent to myocardial recovery, or survived to 180 days post implantation on LVAD support without experiencing a debilitating stroke (MRS >3) or having the device replaced or exchanged. Patients were considered a failure if, within 180 days post implantation, they expired while on LVAD support, experienced a debilitating stroke, had the device replaced or exchanged, had a device explanted for a reason other than myocardial recovery, received an urgent transplant due to malfunction of the device, withdrew from the study for any reason, or did not receive a HeartMate 3 or HeartMate II after randomization.

The HeartMate 3 was to be considered non-inferior to the HeartMate II if the lower bound of the two-sided 95% confidence interval (CI) for the difference in the success rate between the two study arms (HeartMate 3 - HeartMate II) was greater than the non-inferiority margin of -10%. Additionally, if HeartMate 3 were found to be non-inferior to HeartMate II, the protocol specified that the primary composite endpoint would also be analyzed sequentially for superiority at a one-sided 0.025 level of significance.

Secondary endpoints were evaluated descriptively, including adverse events, hospitalizations, reoperations, quality of life (EQ-5D-5L and KCCQ at 6 months), functional status (NYHA Class and 6MWT), and device malfunctions. In addition, a number of subgroup analyses were prespecified including gender, race, Interagency Registry for Mechanically Assisted Circulatory Support (INTERMACS) profile, or intended use of the device (BTT vs. DT). The secondary endpoints were evaluated using the As Treated (AT) population and were assessed at exactly 180 days except the quality of life and the functional status, which were assessed at 6 months (180 ± 30 days).

Accountability of PMA Cohort

At the time of database lock, of 294 patients enrolled in the ST Cohort trial, 98.3% (289) patients were available for analysis at the completion of the study, the 6-month post-operative visit. The disposition of the patients is shown in **Figure A.1**. All 294 patients were consented and randomized, 152 patients to the HeartMate 3 arm and 142 patients to the HeartMate II arm, which comprise the ITT population. Five (5) patients were withdrawn after randomization but before receiving a device, one (1) in the HeartMate 3 arm and four (4) in the HeartMate II arm. As such, the AT population consists of 289 patients, 151 in the HeartMate 3 arm and 138 in the HeartMate II arm.

Figure A.1 Disposition of MOMENTUM 3 Patients in the ST Cohort

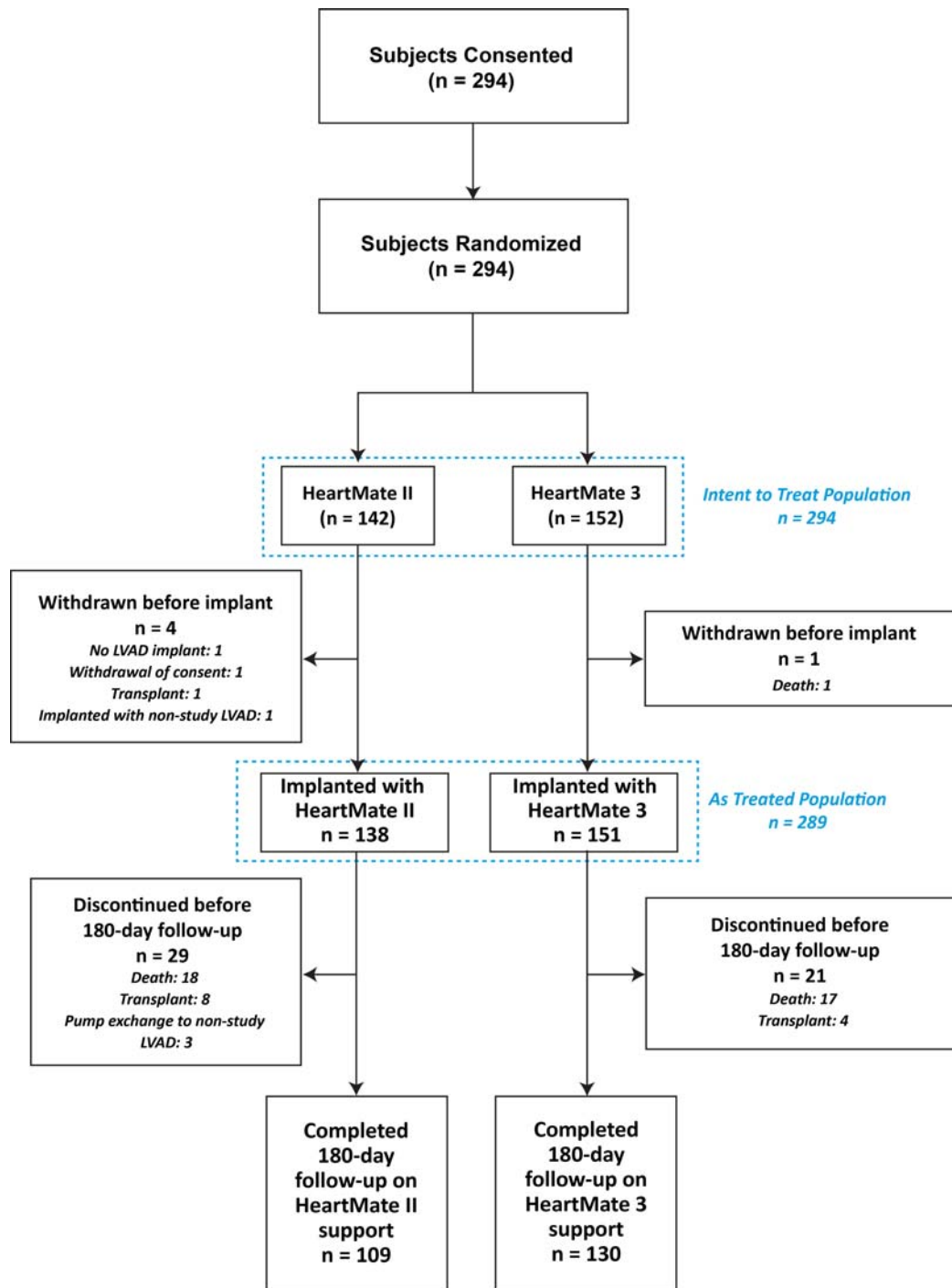

Study Population Demographics and Baseline Parameters

The demographics and baseline characteristics of the study population, as summarized in **Table A.1**, are typical for an LVAD study performed in the U.S. The two study arms were well-balanced, with no significant difference in demographics, intended use, INTERMACS profile, functional status, exercise tolerance, or baseline inotropes.

Demographics and Baseline Characteristics	Summary Statistics*		p-Value [†]
	HeartMate II (n=142)	HeartMate 3 (n=152)	
Age - year	58.9 ± 12.0	60.3 ± 12.3	0.3076
Body-surface area - m ²	2.1 ± 0.3	2.1 ± 0.3	0.6428
Body-mass index - kg/m ²	28.5 ± 5.7	28.8 ± 5.6	0.6200
Weight - kg	87.4 ± 19.7	88.5 ± 20.0	0.6399
Male sex	114 (80.3%)	121 (79.6%)	1.0000
Ischemic cause of heart failure	73 (51.4%)	68 (44.7%)	0.3501
Race			
White	107 (75.4%)	104 (68.4%)	0.1973
Non-white	35 (24.6%)	48 (31.6%)	
Intended use			
Bridge to transplant (BTT) [‡]	37 (26.1%)	41 (27.0%)	0.9784
Possibly BTT: Likely to be eligible	16 (11.3%)	18 (11.8%)	
Possibly BTT: moderate likelihood	9 (6.3%)	7 (4.6%)	
Possibly BTT: unlikely to be eligible	2 (1.4%)	2 (1.3%)	
Destination therapy (DT)	78 (54.9%)	84 (55.3%)	
INTERMACS profile [§]			
1	4 (2.8%)	1 (0.7%)	0.7180
2	44 (31.0%)	50 (32.9%)	
3	69 (48.6%)	76 (50.0%)	
4	23 (16.2%)	22 (14.5%)	
5	2 (1.4%)	2 (1.3%)	
6 or 7	0 (0.0%)	0 (0.0%)	
Not provided	0 (0.0%)	1 (0.7%)	

Table A.1 Patient Demographics and Baseline Characteristics (ITT Population)

Demographics and Baseline Characteristics	Summary Statistics*		P-Value [†]
	HeartMate II (n=142)	HeartMate 3 (n=152)	
NYHA Class ^b			
Class I	0 (0.0%)	0 (0.0%)	0.3811
Class II	0 (0.0%)	0 (0.0%)	
Class IIIB	4 (2.8%)	8 (5.3%)	
Class IV	138 (97.2%)	144 (94.7%)	
Baseline cardiovascular history			
Coronary artery disease	79 (55.6%)	83 (54.6%)	0.9068
Myocardial infarction	53 (37.3%)	54 (35.5%)	0.8086
Left ventricular aneurysm/repair	1 (0.7%)	2 (1.3%)	1.0000
Arrhythmias	104 (73.2%)	113 (74.3%)	0.8946
Supraventricular arrhythmias	71 (50.0%)	74 (48.7%)	0.9071
Ventricular arrhythmias	59 (41.5%)	69 (45.4%)	0.5566
Congenital heart disease	1 (0.7%)	0 (0.0%)	0.4830
Revascularization	61 (43.0%)	59 (38.8%)	0.4789
Valve replacement/repair	6 (4.2%)	13 (8.6%)	0.1579
Valve insufficiency	121 (85.2%)	133 (87.5%)	0.6120
CRT/CRT-D [#]	51 (35.9%)	59 (38.8%)	0.6310
Defibrillator (ICD/CRT-D)	100 (70.4%)	101 (66.4%)	0.5306
Pacemaker	8 (5.6%)	9 (5.9%)	1.0000
Ongoing IABP [#]	21 (14.8%)	18 (11.8%)	0.4945
Hypertension	95 (66.9%)	103 (67.8%)	0.9014

Table A.1 Patient Demographics and Baseline Characteristics (ITT Population)

Demographics and Baseline Characteristics	Summary Statistics*		P-Value [†]
	HeartMate II (n=142)	HeartMate 3 (n=152)	
Baseline medical history			
Neurological history	30 (21.1%)	36 (23.6%)	0.6752
Transient ischemic attack (TIA)	10 (7%)	16 (10.5%)	0.3124
Cerebrovascular accident: Ischemic	11 (7.7%)	11 (7.2%)	1.0000
Cerebrovascular accident: Hemorrhagic	1 (0.7%)	0 (0.0%)	0.4830
Cerebrovascular accident: Not specified	2 (1.4%)	1 (0.7%)	0.6113
Seizure	2 (1.4%)	1 (0.7%)	0.6113
Neurological other	9 (6.3%)	12 (7.9%)	0.6559
Psychiatric history	40 (28.2%)	28 (18.4%)	0.0533
Psychosocial issues	8 (5.6%)	8 (5.3%)	1.0000
Substance abuse	10 (7%)	5 (3.3%)	0.1868
Gastrointestinal history	48 (33.8%)	62 (40.8%)	0.2297
Renal insufficiency	36 (25.4%)	30 (19.7%)	0.2657
Renal failure	6 (4.2%)	10 (6.6%)	0.4461
Cancer History	22 (15.5%)	22 (14.5%)	0.8706
Previous organ transplant history	0 (0.0%)	0 (0.0%)	-
Endocrine history	76 (53.5%)	89 (58.6%)	0.4117
Diabetes mellitus: Insulin-dependent	22 (15.5%)	40 (26.3%)	0.0314
Diabetes mellitus: Non insulin-dependent	32 (22.5%)	30 (19.7%)	0.5704
Hematopoietic/lymphatic history	23 (16.2%)	22 (14.5%)	0.7468

*Continuous measures - Mean \pm SD; categorical measures - no. (%)

[†]Continuous measures - Two-sample t-test; categorical measures - Fisher's exact test

[‡]BTT is defined as listed or planned to be listed within 24 hours

[§]https://www.uab.edu/medicine/intermacs/images/protocol_4.0/protocol_4.0_MoP/Appendix_O_Intermacs_Patient_Profile_at_time_of_implant.pdf

^{||} Subject expired prior to INTERMACS assessment

[¶] NYHA IIIB is defined per protocol as NYHA Class III with dyspnea upon mild physical activity; subjects who were inotrope-dependent were considered NYHA Class IV per protocol

[#] Abbreviations: ICD - implantable cardioverter defibrillator; CRT - cardiac resynchronization therapy device; CRT-D - cardiac resynchronization therapy device with defibrillator; IABP - intra-aortic balloon pump

Table A.1 Patient Demographics and Baseline Characteristics (ITT Population)

Safety and Effectiveness Results

Primary Endpoint

The analysis of the primary endpoint was based on the 294 evaluable patients at the 6-month time point, including 152 HeartMate 3 patients and 142 HeartMate II patients. One hundred thirty-one (131) of the 152 (86.2%) HeartMate 3 patients achieved success in the primary composite endpoint compared to 109 of 142 (76.8%) HeartMate II patients.

The analyses of the primary endpoint are summarized in **Table A.2**. The results show that in both the ITT and AT analyses, the trial met its primary endpoint and demonstrated non-inferiority of the HeartMate 3 as compared to the HeartMate II.

Once non-inferiority was demonstrated, the data were then analyzed to test the superiority of the HeartMate 3 compared to HeartMate II. The test in the ITT population resulted in a significant finding ($p = 0.019$, one-sided), indicating that the HeartMate 3 is superior to the HeartMate II. The difference between the two arms was primarily driven by a higher number of pump exchange and urgent transplants in the HeartMate II arm. However, the finding of superiority was not corroborated by the AT analysis and by a subsequent sensitivity analysis of patients who withdrew from the study. Based on the totality of the analyses, the superiority of the HeartMate 3 over the HeartMate II in terms of the primary endpoint cannot be claimed.

Adverse Events	Intent-to-Treat Analysis		As-Treated Analysis	
	HeartMate II	HeartMate 3	HeartMate II	HeartMate 3
Total # of patients	142	152	138	151
Alive free of debilitating stroke or device replacement	103	127	103	127
Elective transplant	6	4	6	4
Total # of successes	109	131	109	131
Success rate at 6 months	76.8%	86.2%	79.0%	86.8%
Difference (HeartMate 3 – HeartMate II)	9.4%		7.8%	
Exact 95% confidence interval	[-2.1%, 20.7%]		[-3.8%, 19.2%]	
Non-inferiority limit	-10%		-10%	
Primary objective – non-inferiority				
Z-Score	4.2031		3.9276	
p-value	<0.0001		<0.0001	
Non-inferiority test	Passed		Passed	

Table A.2 Analyses of the Primary Endpoint

Adverse Events	Intent-to-Treat Analysis		As-Treated Analysis	
	HeartMate II	HeartMate 3	HeartMate II	HeartMate 3
Primary objective – superiority				
Z-Score	4.3482		3.0912	
p-value	0.019		0.0394	
Superiority test	Passed		Failed	

Table A.2 Analyses of the Primary Endpoint

The Kaplan-Meier curve of the primary endpoint is shown in **Figure A.2** and **Figure A.3** for the ITT population and AT population, respectively.

Figure A.2 Kaplan-Meier Curve of the Primary Endpoint (ITT Population)

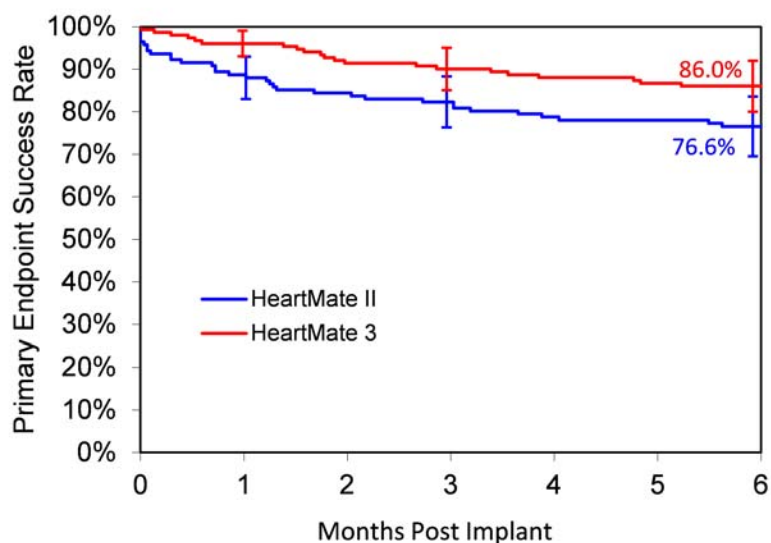

Number of subjects at risk:				
HeartMate II	142	125	116	103
HeartMate 3	152	146	135	127

Note: The confidence intervals were calculated without multiplicity adjustment. The adjusted confidence intervals could be wider than presented here. As such, these confidence intervals are provided to illustrate the variability only and should not be used to draw any statistical conclusion.

Figure A.3 Kaplan-Meier Curve of the Primary Endpoint (AT Population)

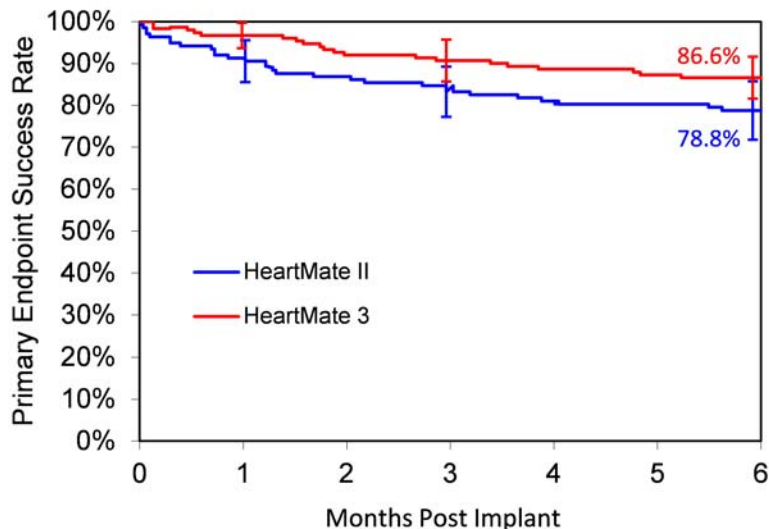

Number of subjects at risk				
HeartMate II	138	125	116	103
HeartMate 3	151	146	135	127

Note: The confidence intervals were calculated without multiplicity adjustment. The adjusted confidence intervals could be wider than presented here. As such, these confidence intervals are provided to illustrate the variability only and should not be used to draw any statistical conclusion.

The details of the outcomes related to the primary composite endpoint for the study are presented below in **Table A.3**.

Key Safety Outcomes*	HeartMate II (n=138)	HeartMate 3 (n=151)
Death	14	13
Debilitating stroke (MRS >3)	4	6
Transplant due to device malfunction	2	0
Pump exchange	9	1
Total failures	29 (21%)	20 (13%)

*For patients who experienced more than one endpoint event during the follow-up period (e.g., debilitating stroke prior to death), the event that occurred first is the failure event listed

Table A.3 Outcomes Related to the Primary Composite Endpoint (AT Population)

Secondary Endpoints

Adverse Events

Table A.4 lists all the pre-specified adverse events that occurred in the AT population; **Table A.5** lists the serious adverse events only. Serious adverse events are defined as those leading to death, congenital abnormality/birth defect, a life-threatening illness/injury that results in permanent disability, hospitalization/prolonged hospitalization, and/or intervention to prevent permanent injury or damage. All adverse events were adjudicated by the CEC for severity and relatedness to the device.

Adverse Events	Summary Statistics*	
	HeartMate II (n=138)	HeartMate 3 (n=151)
Major infection	35% (48, 80)	42% (63, 96)
Localized	26% (36, 58)	30% (46, 57)
Sepsis	7% (9, 10)	9% (14, 19)
Driveline	7% (9, 11)	12% (18, 21)
Pump pocket or pseudo pocket	1% (1, 1)	1% (1, 1)
Pump or pump components	0% (0, 0)	0% (0, 0)
Bleeding	39% (54, 98)	33% (50, 100)
Bleeding requiring surgery	14% (19, 21)	10% (15, 15)
Gastrointestinal bleeding	15% (21, 36)	16% (24, 47)
Cardiac arrhythmia	38% (52, 68)	31% (47, 61)
Ventricular arrhythmia	20% (27, 37)	18% (27, 33)
Supraventricular arrhythmia	22% (30, 31)	15% (23, 27)
Both (ventricular and supraventricular arrhythmia)	0% (0, 0)	1% (1, 1)
Right heart failure	25% (34, 36)	30% (45, 49)
Right ventricular assist device (RVAD)	6% (8, 8)	3% (4, 4)
Respiratory failure	17% (24, 27)	22% (33, 44)
Renal dysfunction	9% (12, 12)	11% (17, 18)
Stroke	11% (15, 17)	8% (12, 12)
Hemorrhagic stroke	6% (8, 8)	3% (4, 4)
Ischemic stroke	7% (9, 9)	5% (8, 8)
Debilitating stroke	4% (5, 5)	6% (9, 9)

Table A.4 All Adverse Events at 6 Months (AT Population)

Adverse Events	Summary Statistics*	
	HeartMate II (n=138)	HeartMate 3 (n=151)
Other neurological event	6% (8, 8)	6% (9, 9)
Encephalopathy	1% (1, 1)	2% (3, 3)
Seizure	2% (3, 3)	3% (4, 4)
Transient ischemic attack (TIA)	1% (1, 1)	1% (1, 1)
Other†	2% (3, 3)	1% (1, 1)
Hepatic dysfunction	2% (3, 3)	5% (7, 7)
Psychiatric episode	6% (8, 9)	5% (7, 7)
Venous thromboembolism	5% (7, 7)	5% (8, 9)
Hypertension	6% (8, 9)	3% (4, 9)
Arterial non-CNS thromboembolism	2% (3, 3)	2% (3, 3)
Pericardial fluid collection	4% (5, 5)	2% (3, 4)
Myocardial infarction	1% (1, 1)	1% (1, 1)
Wound dehiscence	1% (2, 2)	1% (1, 1)
Hemolysis (not associated with suspected device thrombosis)	1% (2,2)	1% (1, 1)
Suspected device thrombosis	10% (14, 18)	0% (0, 0)
Other adverse events	37% (51, 84)	50% (76, 134)

*% patients (# patients, # events)

†Other includes anoxic brain injury, traumatic brain injury, and intracranial bleed due to trauma.

Table A.4 All Adverse Events at 6 Months (AT Population)

Adverse Events	Summary Statistics*	
	HeartMate II (n=138)	HeartMate 3 (n=151)
Major infection	30% (41, 67)	37% (56, 84)
Localized	22% (31, 49)	28% (42, 49)
Sepsis	7% (9, 10)	9% (14, 19)
Driveline	4% (5, 7)	10% (15, 17)
Pump pocket or pseudo pocket	1% (1, 1)	1% (1, 1)
Pump or pump components	0% (0, 0)	0% (0, 0)
Bleeding	37% (51, 90)	30% (45, 85)
Bleeding requiring surgery	14% (19, 21)	10% (15, 15)
Gastrointestinal bleeding	15% (21, 34)	15% (23, 45)
Right heart failure	25% (34, 36)	30% (45, 49)
Right ventricular assist device (RVAD)	6% (8, 8)	3% (4, 4)
Cardiac arrhythmia	33% (46, 58)	26% (39, 50)
Ventricular arrhythmia	20% (27, 37)	18% (27, 33)
Supraventricular arrhythmia	15% (21, 21)	9% (14, 16)
Both (ventricular and supraventricular arrhythmia)	0% (0, 0)	1% (1, 1)
Respiratory failure	17% (24, 27)	22% (33, 44)
Renal dysfunction	9% (12, 12)	11% (17, 18)
Stroke	11% (15, 17)	8% (12, 12)
Hemorrhagic stroke	6% (8, 8)	3% (4, 4)
Ischemic stroke	7% (9, 9)	5% (8, 8)
Debilitating stroke	4% (5, 5)	6% (9, 9)
Other neurological event	6% (8, 8)	6% (9, 9)
Encephalopathy	1% (1, 1)	2% (3, 3)
Seizure	2% (3, 3)	3% (4, 4)
Transient ischemic attack (TIA)	1% (1, 1)	1% (1, 1)
Other†	2% (3, 3)	1% (1, 1)

Table A.5 Serious Adverse Events at 6 Months (AT Population)

Adverse Events	Summary Statistics*	
	HeartMate II (n=138)	HeartMate 3 (n=151)
Hepatic dysfunction	2% (3, 3)	5% (7, 7)
Venous thromboembolism	5% (7, 7)	4% (6, 7)
Psychiatric episode	5% (7, 7)	3% (5, 5)
Arterial non-CNS thromboembolism	2% (3, 3)	2% (3, 3)
Hypertension	1% (1, 1)	2% (3, 3)
Pericardial fluid collection	3% (4, 4)	2% (3, 4)
Myocardial infarction	1% (1, 1)	1% (1, 1)
Wound dehiscence	1% (2, 2)	1% (1, 1)
Hemolysis (not associated with suspected device thrombosis)	1% (2,2)	1% (1, 1)
Suspected device thrombosis	10% (14, 18)	0% (0, 0)
Other adverse events	35% (48, 75)	48% (73, 117)

*% patients (# patients, # events)

†Other includes anoxic brain injury, traumatic brain injury, and intracranial bleed due to trauma.

Table A.5 Serious Adverse Events at 6 Months (AT Population)

Rehospitalizations

Eighty-nine (89) of the 140 HeartMate 3 patients (64%) discharged from the hospital reported a total of 178 readmissions as compared to 81 of the 126 discharged HeartMate II patients (64%) reporting a total of 159 readmissions. The Kaplan-Meier plot of rehospitalization is shown in **Figure A.4**.

Figure A.4 Rehospitalization Following Discharge from Implantation Surgery

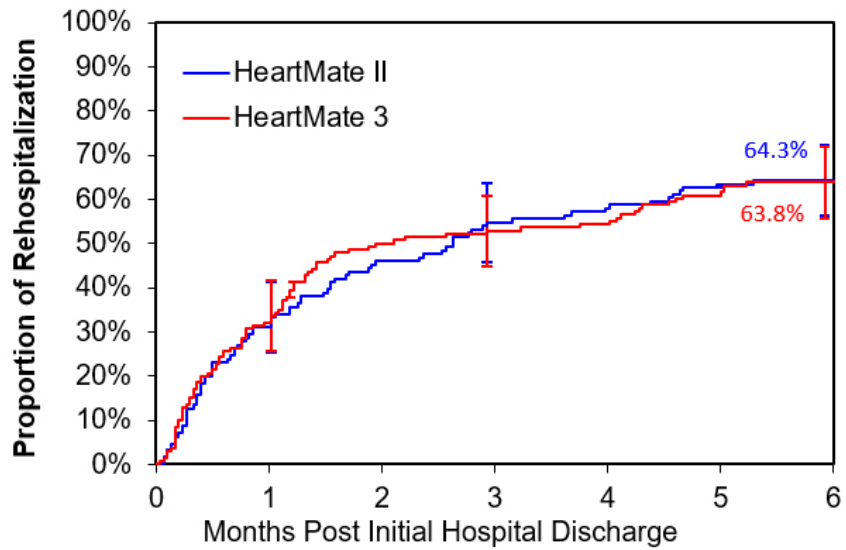

Number of Subjects at Risk:

HeartMate II	126	87	57	43
HeartMate 3	140	95	65	42

Note: The confidence intervals are calculated without multiplicity adjustment. The adjusted confidence intervals could be wider than presented here. As such, these confidence intervals are provided to illustrate the variability only and should not be used to draw any statistical conclusion

Reoperations

All surgical procedures that occurred after the initial implantation surgery are summarized in **Table A.6**. Cardiac transplants due to device malfunctions are included as a reoperation; elective cardiac transplants are not. Forty-six (46) of the 151 HeartMate 3 patients (30.5%) required a total of 74 reoperations by 6 months post implantation, as compared to 52 of the 138 HeartMate II

patients (37.7%) requiring a total of 87 reoperations. A large number of peri-implant reoperations were due to mediastinal exploration and delayed chest closure.

Operation	HeartMate II	HeartMate 3
Mediastinal exploration	19	15
Delayed chest closure	5	17
Replace/exchange device	11	1
RVAD implantation or removal	10	8
Cardiac transplant	2	0
Other – cardiac/vascular	10	3
Gastrointestinal	9	7
Respiratory	7	10
Other	14	13
Total	87	74

Table A.6 Reoperations at 6 Months

Device Malfunctions

At 6 months, 40 of the 151 (26%) HeartMate 3 patients reported 48 suspected device malfunctions; 29 of the 138 (21%) HeartMate II patients reported 46 suspected device malfunctions, as summarized in **Table A.7**. The majority of malfunctions in both arms involved external components, most commonly the System Controller.

	#Patients	%Patients	Events
HeartMate II (n=138)	29	21.0%	46
HeartMate 3 (n=151)	40	26.5%	48

Table A.7 Suspected Device Malfunctions at 6 Months

Of the 48 suspected HeartMate 3 device malfunctions, seven (7) were associated with adverse clinical effects as shown in **Figure A.5**. Adverse clinical effects included intraoperative bleeding, reshospitalization for pump replacement and shortness of breath.

Figure A.5 Suspected HeartMate 3 LVAS Malfunctions

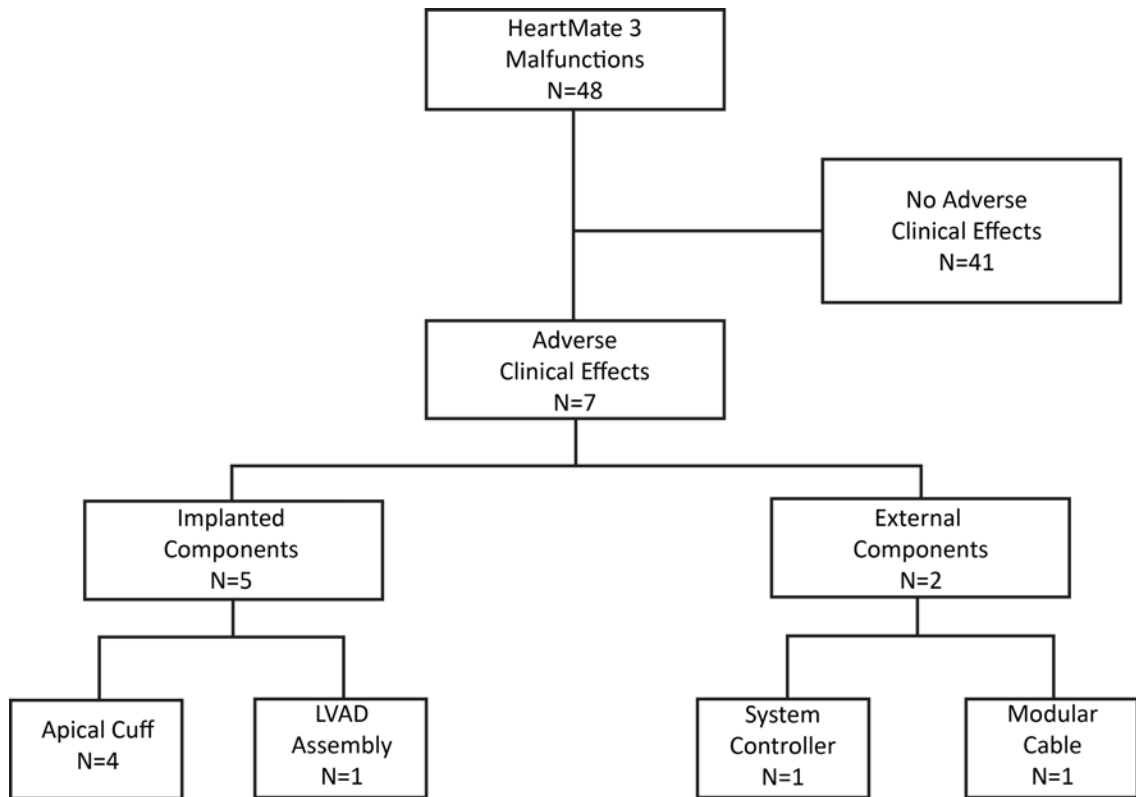

Functional Status

Functional status was assessed by the NYHA class and the 6-minute walk test (6MWT), as shown in **Figure A.6** and **Figure A.7**. All patients were in NYHA Class III or IV at baseline, the proportion decreased to 23% in the HeartMate 3 arm and to 17% in the HeartMate II arm at 6 months. The average 6MWT distance increased from 164 m at baseline to 300 m at 6 months in the HeartMate 3 arm; the same distance increased from 128 m to 335 m in the HeartMate II arm.

Figure A.6 NYHA Class over Time

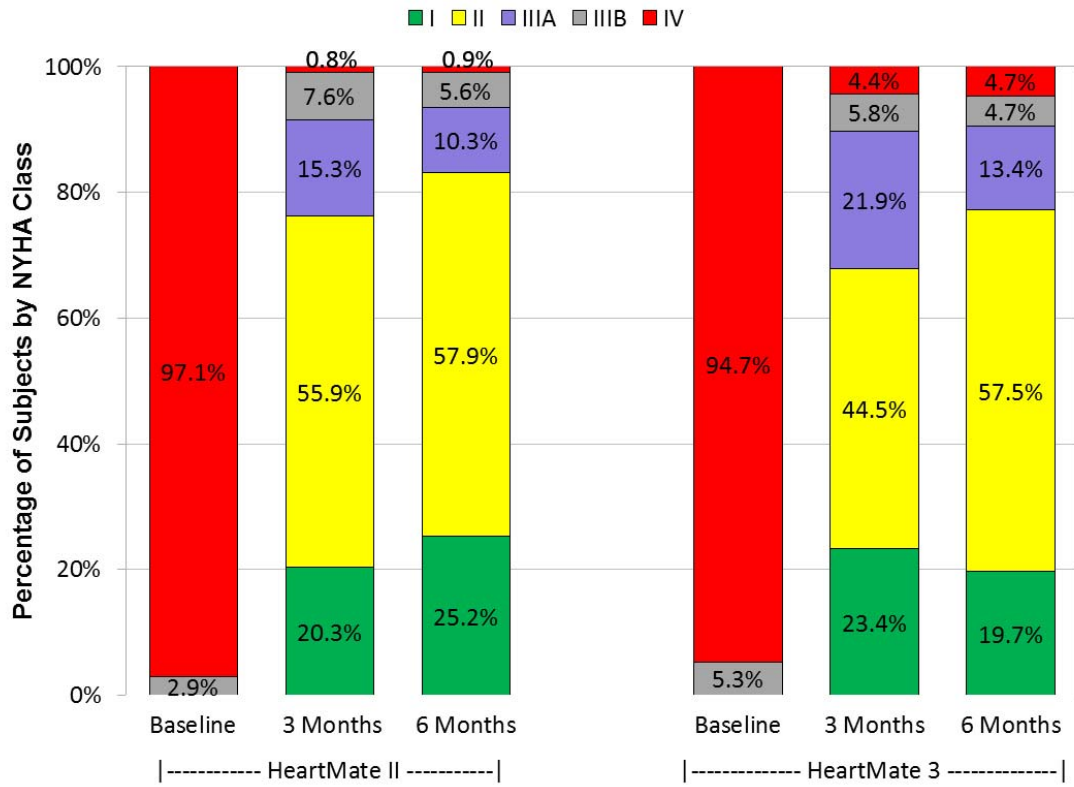
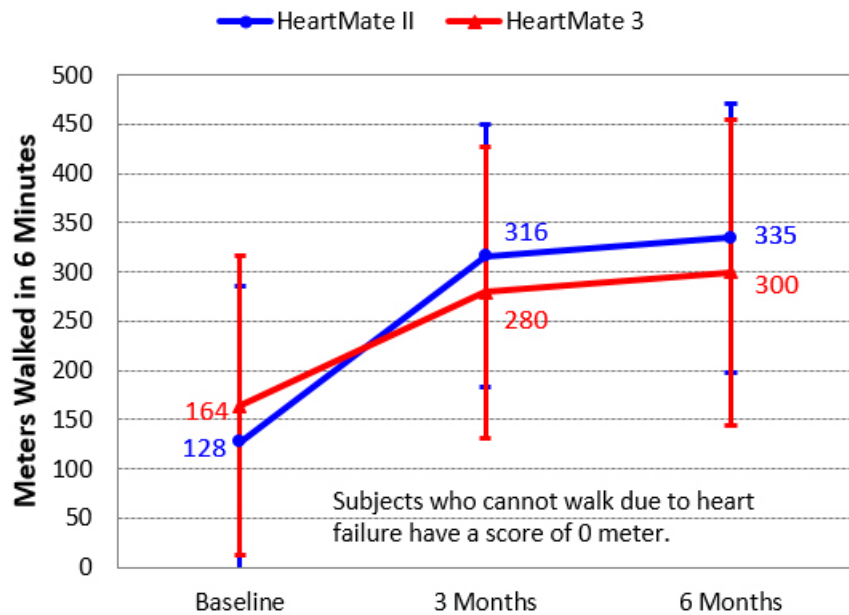

Figure A.7 6MWT Distance over Time



Quality of Life

The quality of life was assessed by the EQ-5D-5L and the KCCQ questionnaires, as summarized in **Figure A.8**, **Figure A.9**, **Figure A.10**, and **Figure A.11**. Patients in both arms showed comparable improvements in the total EQ-5D-5L Score, the EQ-5D-5L Visual Analog Score, the KCCQ Overall Summary Score, and the KCCQ Clinical Summary Score over time.

Figure A.8 Total EQ-5D-5L Score over Time (AT Population)

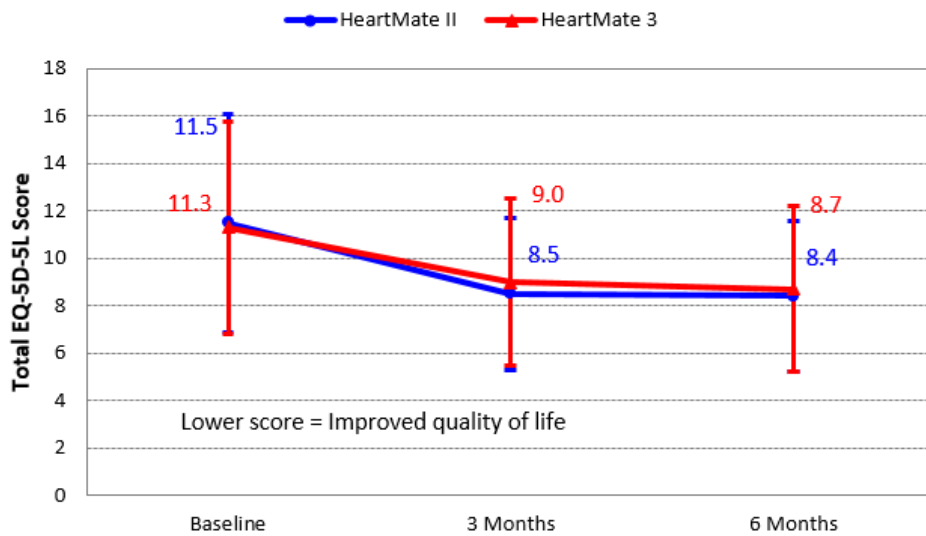

Figure A.9 EQ-5D-5L Visual Analog Score over Time (AT Population)

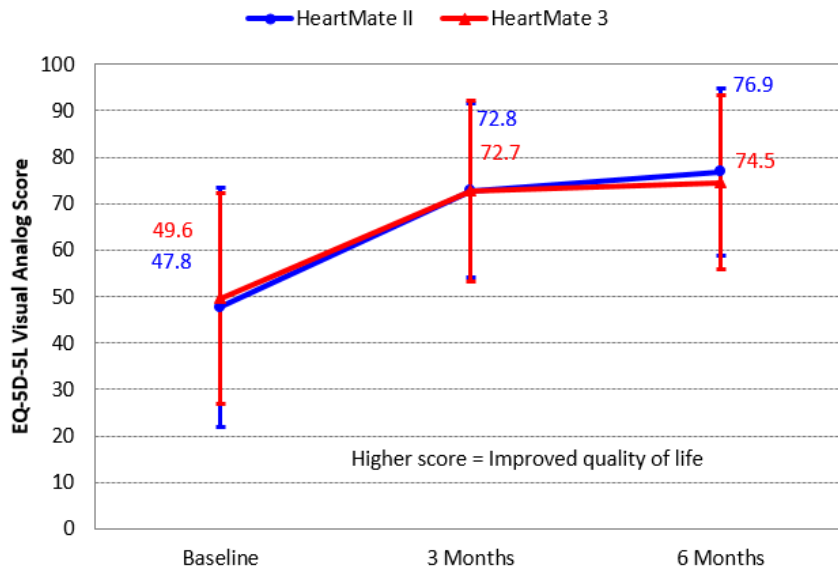

Figure A.10 KCCQ Overall Summary Score over Time (AT Population)

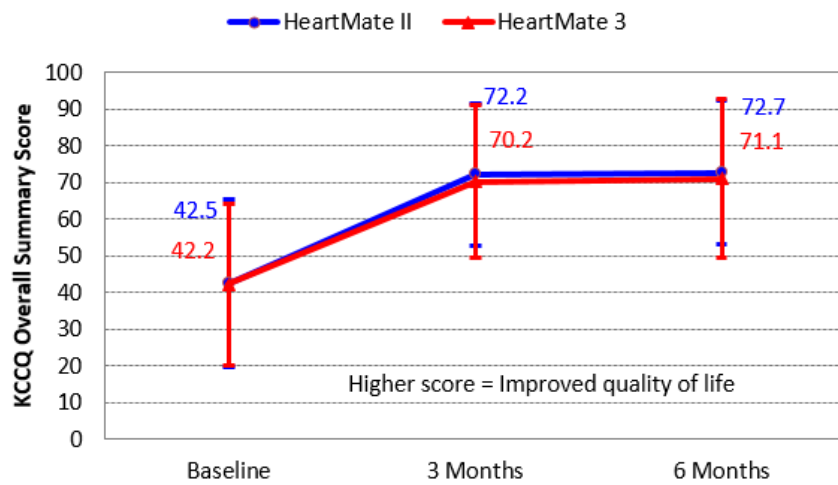
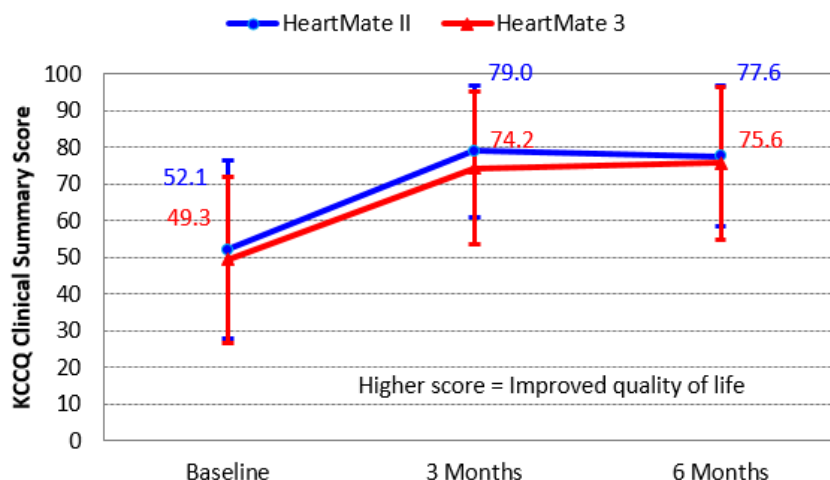

Figure A.11 KCCQ Clinical Summary Score over Time (AT Population)



Subgroup Analyses

Prespecified sub-group analyses showed no major clinical differences in outcomes based on gender, race, INTERMACS profile, or intended use of the device (BTT vs. DT).

Other Results

Causes of Death

To determine cause-specific death, all deaths were reviewed and adjudicated by the CEC. A summary of patient deaths at 6 months in the AT population is provided in **Table A.8**.

Adjudicated Cause of Death	Number of Events	
	HeartMate II (n=138)	HeartMate 3 (n=151)
Cardiopulmonary		
Right heart failure	9	4
Respiratory failure	0	1
Ventricular fibrillation	1	0
Brain related		
Stroke	3	5
Traumatic subdural hematoma (caused by a fall)	0	1
Anoxic brain injury (secondary to respiratory failure)	0	1

Table A.8 Adjudicated Causes of Death (AT Population)

Adjudicated Cause of Death	Number of Events	
	HeartMate II (n=138)	HeartMate 3 (n=151)
Bleeding		
Abdominal bleeding	1	0
Aortic dissection	1	0
Gastrointestinal bleeding	0	1*
Infection		
Sepsis	0	2
Pneumonia	1	0
Device-related		
Driveline disconnect	0	1†
Pump thrombosis	1‡	0
Miscellaneous		
Hepatic failure	1	0
Metastatic cervical cancer	0	1
Total	18	17

*Patient died as a result of GI bleeding associated with surgery for an obstructed bowel.

†Patient died as a result of disconnecting the driveline after receiving an alarm due to reversed power cable connections to the Mobile Power Unit.

‡Patient died of worsening heart failure secondary to pump thrombosis after declining a pump exchange.

Table A.8 Adjudicated Causes of Death (AT Population)

The Kaplan-Meier curve of all-cause mortality for the AT population is shown in **Figure A.12**.

Figure A.12 All-Cause Mortality (AT Population)

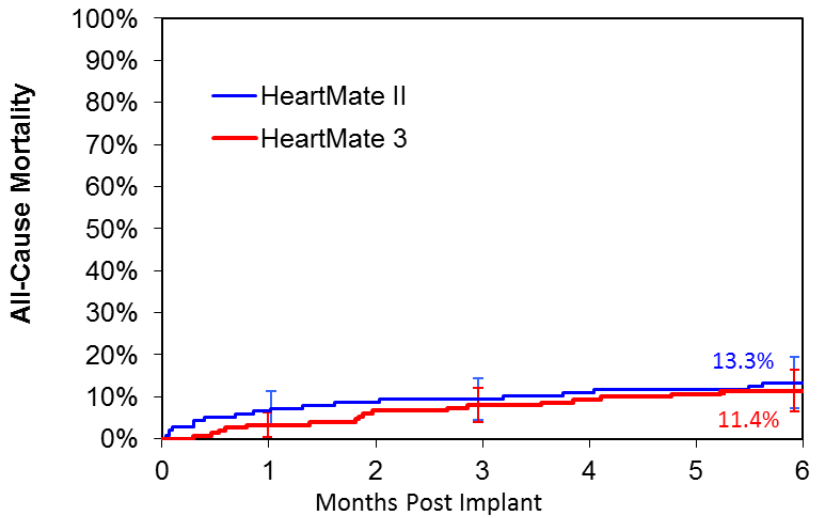

Number of Subjects at Risk:

HeartMate II	138	128	121	109
HeartMate 3	151	146	137	130

Note: The confidence intervals are calculated without multiplicity adjustment. The adjusted confidence intervals could be wider than presented here. As such, these confidence intervals are provided to illustrate the variability only and should not be used to draw any statistical conclusion.

Competing Outcomes Analysis

Plots of the competing outcomes (ongoing on LVAS support, expiration, transplantation, exchanged to non-study device) are provided in **Figure A.13** and **Figure A.14** for the HeartMate II and HeartMate 3, respectively.

Figure A.13 Competing Outcomes of HeartMate II Patients at 6 Months

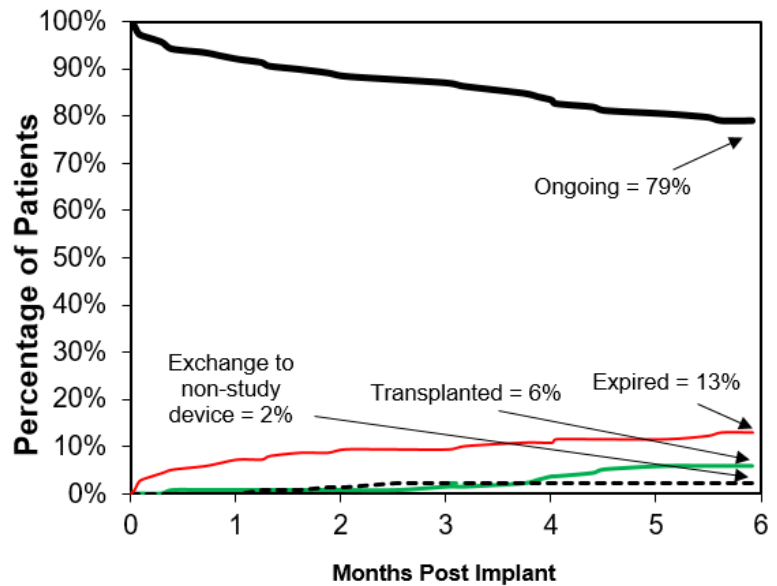
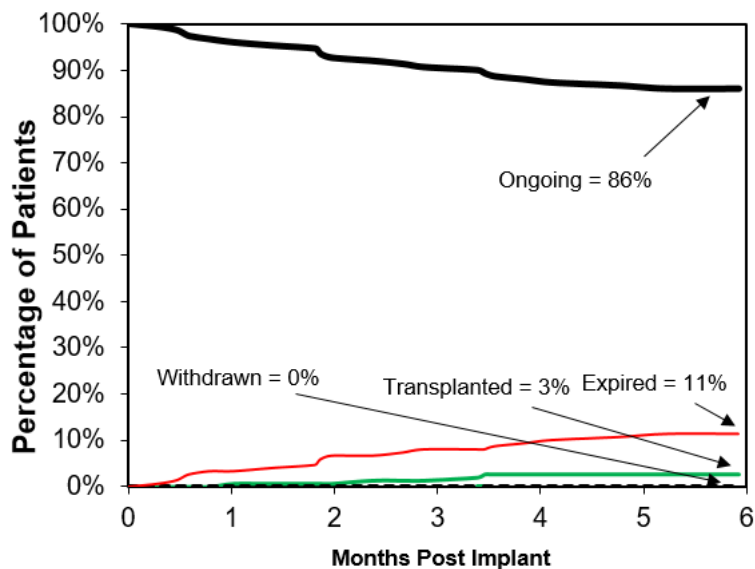

Figure A.14 Competing Outcomes of HeartMate 3 Patients at 6 Months



Summary Of The Study Results - Short Term

The results of the ST Cohort analysis show that the HeartMate 3 LVAS is non-inferior to the HeartMate II LVAS when used for the treatment of patients with advanced refractory left ventricular heart failure as assessed by the primary endpoint of survival free of debilitating stroke or reoperation to replace the pump at six (6) months. Subjects in both arms of the trial demonstrated significant improvement in functional status and quality of life compared to pre-implant baseline. The incidence of serious adverse events (SAEs) was comparable between the two devices with the exception of driveline infections which were more common in the HeartMate 3 LVAS arm and suspected pump thrombosis which was absent in the HeartMate 3 LVAS arm but occurred in 10% of subjects in the HeartMate II LVAS arm.

Long Term Clinical Outcomes

Clinical Endpoints of Long Term Cohort

The primary endpoint for the LT Cohort of the MOMENTUM 3 trial was a composite of survival to transplant, recovery, or 24 months of LVAD support free of debilitating stroke or reoperation to replace the pump. Debilitating stroke was defined as a stroke with Modified Rankin Scale (MRS) >3 assessed at 60 days after the event. The trial required that at least 75 HeartMate 3 LVAS subjects, each with at least 24 months (2 years) of support duration, be available at the time of PMA application.

The primary analysis was performed as intent to treat (ITT) and was performed at 24 months. The as treated (AT) analysis was performed as adjunctive analysis. Patients were considered a success if, within two years post implantation, they

- received a cardiac transplant that was not urgently required due to a device malfunction or adverse event;
- had the device explanted subsequent to myocardial recovery; or
- survived to 24 months post implantation on LVAD support without experiencing a debilitating stroke (MRS > 3) or having the device replaced or exchanged.

Patients were considered a failure if, within 24 months post implantation they

- expired while on LVAD support;
- experienced a debilitating stroke;
- had the device replaced or exchanged;
- had a device explanted for a reason other than myocardial recovery;
- received an urgent transplant due to malfunction or adverse event of the device;
- withdrew from the study for any reason; or
- did not receive a HeartMate 3 LVAS or HeartMate II LVAS after randomization.

The HeartMate 3 LVAS was to be considered non-inferior to the HeartMate II LVAS if the lower bound of the two-sided 95% confidence interval (CI) for the difference in the success rate between the two study arms (HeartMate 3 - HeartMate II) was greater than -10%. Additionally, if the HeartMate 3 LVAS was found to be non-inferior to the HeartMate II LVAS, the protocol specified that the primary composite endpoint would also be analyzed sequentially for superiority at a one-sided 0.025 level of significance.

Secondary endpoints were evaluated descriptively, including adverse events, hospitalizations, reoperations, quality of life (EQ-5D-5L and KCCQ), functional status (NYHA Class and 6MWT), and device malfunctions. In addition, a number of subgroup analyses were prespecified including gender, race, Interagency Registry for Mechanically Assisted Circulatory Support (INTERMACS) profile, and intended use of the device (BTT vs. DT). The secondary endpoints were evaluated using the AT population and were assessed at 24 months.

Accountability of Long Term Cohort PMA

At the time of database lock, of 366 subjects enrolled in the LT Cohort trial, 98.6% (361) of the subjects were available for analysis at the completion of the study (the 24-month post-operative visit). The disposition of the patients is shown in **Figure A.1**. All 366 subjects were consented and randomized, 190 subjects to the HeartMate 3 arm and 176 subjects to the HeartMate II arm, which comprise the ITT population. Five (5) subjects were withdrawn after randomization but before receiving a device, one (1) in the HeartMate 3 arm and four (4) in the HeartMate II arm. As such, the AT population consists of 361 subjects, 189 in the HeartMate 3 arm and 172 in the HeartMate II arm. Eight (8) subjects were withdrawn after receiving a device, two (2) in the HeartMate 3 arm and six (6) in the HeartMate II arm. All withdrawals were pre-specified to be counted as endpoint failures for the primary analysis.

Disposition of MOMENTUM 3 Patients in the LT Cohort

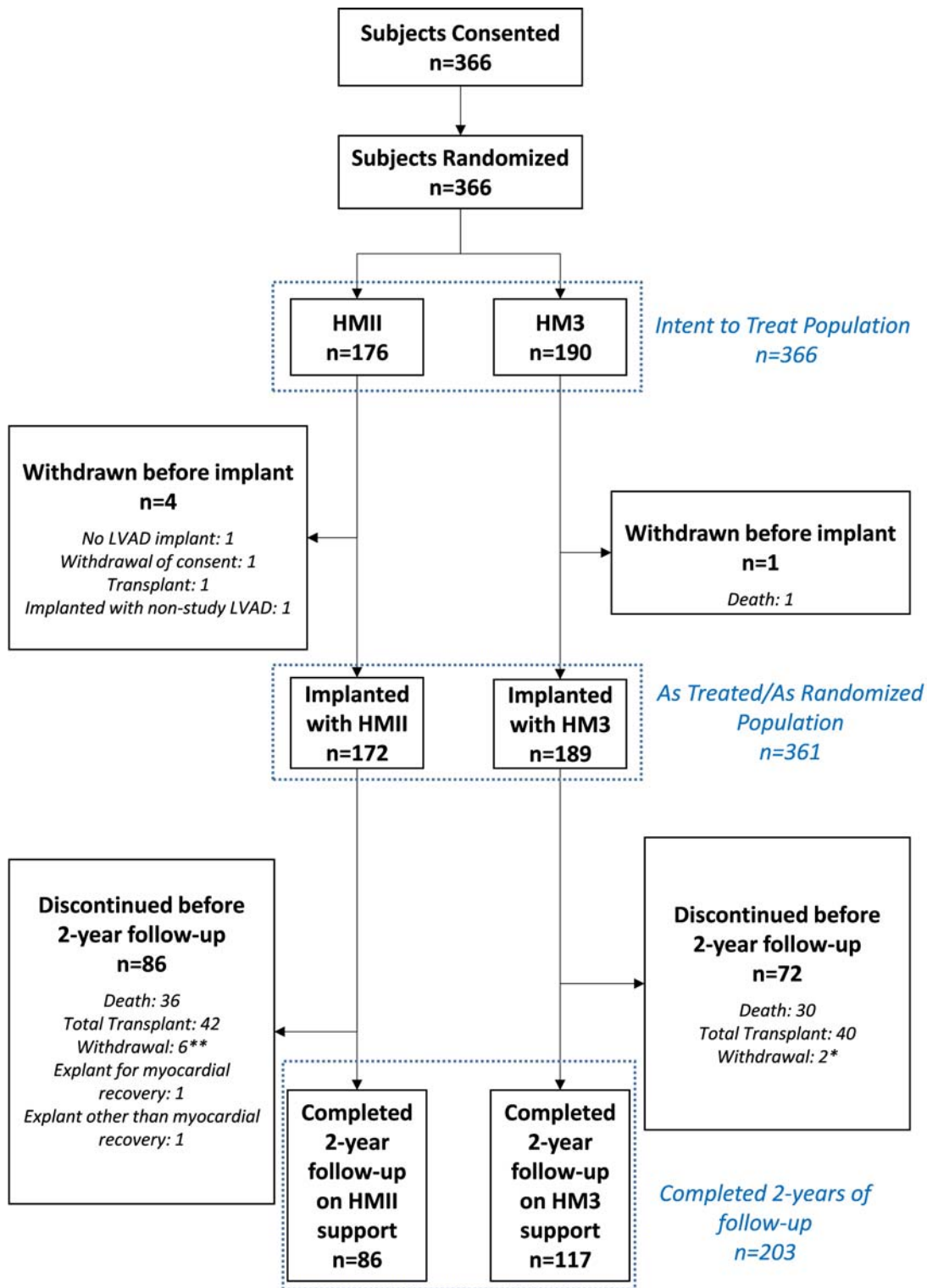

* (1) non-compliance, (1) explant to total artificial heart
 ** (1) withdrew consent, (5) exchange to a non-study or unassigned LVAD

Study Population Demographics and Baseline Parameters - Long Term Cohort

The demographics and baseline characteristics of the study population, as summarized in **Table A.1**, are typical for an LVAD study performed in the U.S. The two study arms were well-balanced, with no significant difference in demographics, intended use, INTERMACS profile, functional status, exercise tolerance, or baseline inotropes.

Overall, 96% of enrolled subjects had NYHA Class IV symptomatology, and 83% were INTERMACS Profile 2 or 3. The majority of subjects within the LT cohort had "DT" as the intended use before implantation.

Demographics and Baseline Characteristics	Summary Statistics*		p-Value [†]
	HeartMate II (n=176)	HeartMate 3 (n=190)	
Age - year	59 ± 12	61 ± 12	0.2288
Body-surface area - m ²	2.1 ± 0.3	2.1 ± 0.3	0.4938
Body-mass index - kg/m ²	28.4 ± 5.8	29 ± 6.2	0.3150
Weight - kg	87.5 ± 20.1	89.1 ± 20.9	0.4471
Male sex	143 (81%)	150 (79%)	0.6028
Ischemic cause of heart failure	88 (50%)	80 (42%)	0.1423
Race			
White	131 (74%)	127 (67%)	0.1358
Non-white	45 (26%)	63 (33%)	
Intended use			
Bridge to transplant (BTT) [‡]	42 (24%)	49 (26%)	0.9903
Possibly BTT: Likely to be eligible	17 (10%)	18 (9%)	
Possibly BTT: moderate likelihood	9 (5%)	9 (5%)	
Possibly BTT: unlikely to be eligible	2 (1%)	3 (2%)	
Destination therapy (DT)	106 (60%)	111 (58%)	

Table A.9 Patient Demographics and Baseline Characteristics (ITT Population)

Demographics and Baseline Characteristics	Summary Statistics*		p-Value†
	HeartMate II (n= 176)	HeartMate 3 (n= 190)	
INTERMACS profile [§]			
1	4 (2%)	1 (1%)	0.5717
2	51 (29%)	61 (32%)	
3	91 (52%)	101 (53%)	
4	28 (16%)	24 (13%)	
5	2 (1%)	2 (1%)	
6 or 7	0 (0%)	0 (0%)	
Not provided	0 (0.0%)	1 (1%)	
NYHA Class ^b			
Class I	0 (0%)	0 (0%)	0.1150
Class II	0 (0%)	0 (0%)	
Class IIIB	4 (2%)	11 (6%)	
Class IV	172 (98%)	179 (94%)	
Baseline cardiovascular history			
Coronary artery disease	97 (55%)	102 (54%)	0.8338
Myocardial infarction	64 (36%)	63 (33%)	0.5828
Left ventricular aneurysm/repair	2 (1%)	2 (1%)	1.0000
Arrhythmias	129 (73%)	141 (74%)	0.9055
Supraventricular arrhythmias	91 (52%)	94 (49%)	0.6771
Ventricular arrhythmias	70 (40%)	84 (44%)	0.3988
Congenital heart disease	1 (1%)	1 (1%)	1.0000
Revascularization	76 (43%)	71 (37%)	0.2863
Valve replacement/repair	7 (4%)	18 (9%)	0.0400
Valve insufficiency	149 (85%)	166 (87%)	0.5460
CRT/CRT-D [#]	62 (35%)	75 (39%)	0.4495
Defibrillator (ICD/CRT-D)	123 (70%)	122 (64%)	0.2673
Pacemaker	11 (6%)	10 (5%)	0.8228
Ongoing IABP [#]	26 (15%)	25 (13%)	0.7628

Table A.9 Patient Demographics and Baseline Characteristics (ITT Population)

Demographics and Baseline Characteristics	Summary Statistics*		p-Value†
	HeartMate II (n= 176)	HeartMate 3 (n= 190)	
Hypertension	119 (68%)	127 (67%)	0.9115
Baseline medical history			
Neurological history	37 (21.0%)	41 (21.6%)	1.0000
Transient ischemic attack (TIA)	11 (6.3%)	18 (9.5%)	0.3332
Cerebrovascular accident: Ischemic	17 (9.7%)	15 (7.9%)	0.5827
Cerebrovascular accident: Hemorrhagic	1 (0.6%)	0 (0%)	0.4809
Cerebrovascular accident: Not specified	2 (1.1%)	1 (0.5%)	0.6101
Seizure	2 (1.1%)	1 (0.5%)	0.6101
Neurological other	10 (5.7%)	12 (6.3%)	0.8295
Psychiatric history	47 (26.7%)	34 (17.9%)	0.0448
Psychosocial issues	9 (5.1%)	8 (4.2%)	0.8051
Substance abuse	11 (6.3%)	6 (3.2%)	0.2145
Gastrointestinal history	59 (33.5%)	74 (38.9%)	0.3277
Renal insufficiency	47 (26.7%)	38 (20.0%)	0.1385
Renal failure	7 (4.0%)	11 (5.8%)	0.4756
Cancer history	26 (14.8%)	30 (15.8%)	0.8846
Previous organ transplant history	0 (0%)	0 (0%)	–
Endocrine history	97 (55.1%)	110 (57.9%)	0.5995
Diabetes mellitus: Insulin-dependent	28 (15.9%)	26 (24.2%)	0.0516
Diabetes mellitus: Non insulin-dependent	41 (23.3%)	41 (21.6%)	0.7084
Hematopoietic/lymphatic history	30 (17.0%)	15 (13.2%)	0.3095

*Continuous measures - Mean ± SD; categorical measures - no. (%)

†Continuous measures - Two-sample t-test; categorical measures - Fisher's exact test

‡BTT is defined as listed or planned to be listed within 24 hours

§ https://www.uab.edu/medicine/intermacs/images/protocol_4.0/protocol_4.0_MoP/Appendix_O_Intermacs_Patient_Profile_at_time_of_implant.pdf

‡ Subject expired prior to INTERMACS assessment

‡ NYHA IIIB is defined per protocol as NYHA Class III with dyspnea upon mild physical activity; subjects who were inotrope-dependent were considered NYHA Class IV per protocol

Abbreviations: ICD - implantable cardioverter defibrillator; CRT - cardiac resynchronization therapy device; CRT-D - cardiac resynchronization therapy device with defibrillator; IABP - intra-aortic balloon pump

Table A.9 Patient Demographics and Baseline Characteristics (ITT Population)

Safety and Effectiveness Results - Long Term Cohort

Primary Endpoint

The analysis of the primary endpoint was based on the 366 evaluable subjects at the 24-month time point, (190 HeartMate 3 patients and 176 HeartMate II subjects), as summarized in **Table A.2**. The results show that in both the ITT and AT analyses, the trial demonstrated non-inferiority of the HeartMate 3 LVAS as compared to the HeartMate II LVAS for the primary endpoint.

Once non-inferiority was demonstrated, the data were then analyzed to test for superiority of the HeartMate 3 LVAS compared to the HeartMate II LVAS for the composite primary endpoint. The superiority test in both the ITT and AT populations resulted in a significant finding ($p < 0.0001$, one-sided), indicating that the HeartMate 3 LVAS was superior to the HeartMate II LVAS in terms of the composite primary endpoint.

Adverse Events	Intent-to-Treat Analysis		As-Treated Analysis	
	HeartMate II	HeartMate 3	HeartMate II	HeartMate 3
Total # of patients	176	190	172	189
Alive free of debilitating stroke or device replacement	75	111	75	111
Elective transplant	30	40	30	40
Explanted due to myocardial recovery	1	0	1	0
Total # of successes	106	151	106	151
Success rate at 24 months	60.2%	79.5%	61.6%	79.9%
Difference (HeartMate 3 – HeartMate II)	19.2%		18.3%	
Exact 95% confidence interval	[9.1%, 29.1%]		[8.0%, 28.2%]	
Non-inferiority limit	-10%		-10%	
Primary objective – non-inferiority				
Z-Score	6.0953		5.9051	
p-value	<0.0001		<0.0001	
Non-inferiority test	Passed		Passed	
Primary objective – superiority				
Z-Score	4.0229		3.8275	
p-value	<0.0001		<0.0001	
Superiority test	Passed		Passed	

Table A.10 Analyses of the Primary Endpoint

The Kaplan-Meier curve reflecting the primary endpoint success rates is shown in **Figure A.2** and **Figure A.3** for the ITT population and AT population, respectively.

Figure A.15 Kaplan-Meier Curve of the Primary Endpoint (ITT Population)

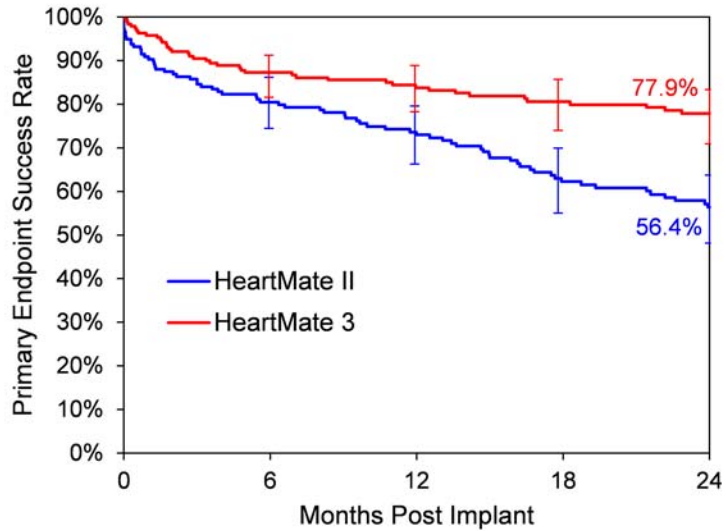

Number of subjects at risk:

HeartMate II	176	134	114	90	75
HeartMate 3	190	161	141	122	111

Note: The confidence intervals were calculated without multiplicity adjustment. The adjusted confidence intervals could be wider than presented here. As such, these confidence intervals are provided to illustrate the variability only and should not be used to draw any statistical conclusion.

Figure A.16 Kaplan-Meier Curve of the Primary Endpoint (AT Population)

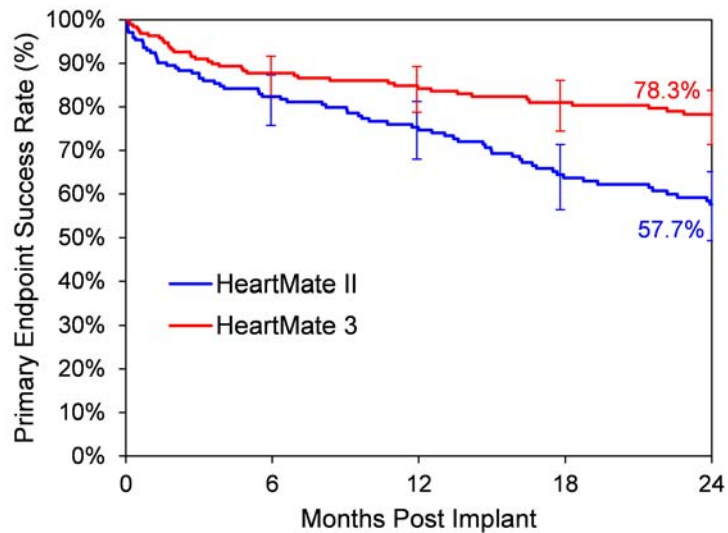

Number of subjects at risk:

HeartMate II	172	134	114	90	75
HeartMate 3	189	161	141	122	111

Note: The confidence intervals were calculated without multiplicity adjustment. The adjusted confidence intervals could be wider than presented here. As such, these confidence intervals are provided to illustrate the variability only and should not be used to draw any statistical conclusion.

The details of the primary composite endpoint outcome in relation to its components are presented below in **Table A.3**. The difference in the primary endpoint result between the two arms was primarily driven by a higher number of pump exchanges and urgent transplants in the HeartMate II arm.

Key Safety Outcomes	HeartMate II (n=172)	HeartMate 3 (n=189)
Death	26	22
Debilitating stroke (MRS >3)	7	11
Transplant due to device malfunction	8	0
Pump exchange	21	3
Withdrawn (post implantation)	1	1

Table A.11 Outcomes Related to the Primary Composite Endpoint (AT Population)

Key Safety Outcomes	HeartMate II (n=172)	HeartMate 3 (n=189)
Withdrawn due to exchange with non-study device	2	1
Explanted other than myocardial recovery	1	0
Total failure	66 (38%)	38 (20%)
*For patients who experienced more than one endpoint event during the follow-up period (e.g., debilitating stroke prior to death), the event that occurred first is the failure event listed.		

Table A.11 Outcomes Related to the Primary Composite Endpoint (AT Population)

More detailed analyses of survival, debilitating stroke, and pump exchange are shown below:

Survival

The Kaplan-Meier curve for survival is shown in **Figure A.17**. Survival at 24 months (data censored at the time of transplantation or device exchange) was similar in the two arms.

Figure A.17 Kaplan-Meier Curve for Survival (AT Population)

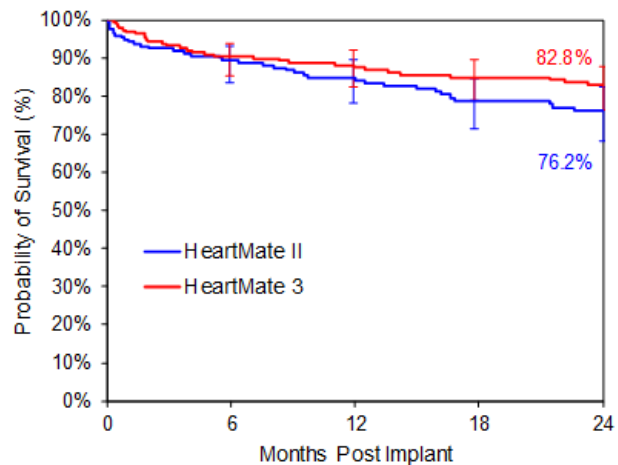

Number of subjects at risk:					
HeartMate II	172	141	121	98	86
HeartMate 3	189	165	146	127	117

Note: The confidence intervals were calculated without multiplicity adjustment. The adjusted confidence intervals could be wider than presented here. As such, these confidence intervals are provided to illustrate the variability only and should not be used to draw any statistical conclusion.

All deaths were reviewed and adjudicated by the CEC. A summary of patient deaths at 24 months in the AT population is provided in **Table A.12**.

Adjudicated Cause of Death	Number of Events	
	HeartMate II (n=172)	HeartMate 3 (n=189)
Cardiopulmonary		
Heart failure	0	1
Right heart failure	9	6
Respiratory failure	1	1
Ventricular arrhythmia	1	2
Brain related		
Stroke	6	6
Traumatic subdural hematoma (caused by a fall)	0	1
Anoxic brain injury (secondary to respiratory failure)	0	1
Intracranial hemorrhage (due to trauma)	1	0
Bleeding related		
Abdominal or gastrointestinal bleeding	2	1
Aortic dissection	1	0
Infection related		
Infection or sepsis	6	6
Pneumonia	1	0
Device-related		
Driveline disconnect*	0	2*
Pump thrombosis [†]	4 [†]	0
Miscellaneous		
Cancer	0	2
Hepatic failure	2	0

Adjudicated Cause of Death	Number of Events	
	HeartMate II (n=172)	HeartMate 3 (n=189)
Intravenous drug use	0	1
Unknown	2	0
Total	36	30

*One patient died as a result of disconnecting the driveline after receiving an alarm due to reversed power cable connections to the Mobile Power Unit. One patient died after an unintentional driveline disconnect occurred while changing the batteries.

†Three patients declined a pump exchange and died as a result of their worsening condition and heart failure. One patient also developed sepsis and renal failure and opted for comfort care only.

Table A.12 Adjudicated Causes of Death (AT Population)

Debilitating Stroke

The Kaplan-Meier curve for freedom from debilitating stroke is shown in **Figure A.18**.

Figure A.18 Kaplan-Meier Curve for Freedom from Debilitating Stroke (AT Population)

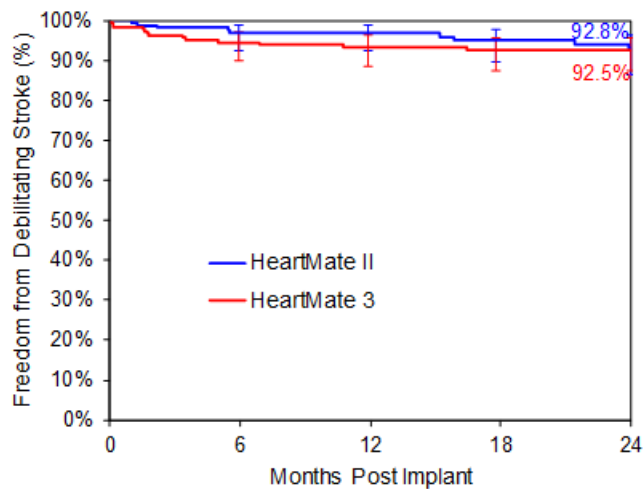

Number of subjects at risk:					
HeartMate II	172	139	121	97	84
HeartMate 3	189	162	142	123	114

Note: The confidence intervals were calculated without multiplicity adjustment. The adjusted confidence intervals could be wider than presented here. As such, these confidence intervals are provided to illustrate the variability only and should not be used to draw any statistical conclusion.

Pump Exchange or Removal

The Kaplan-Meier curve for freedom from pump exchange or removal is shown in **Figure A.19**. The majority of device exchanges were precipitated by suspected pump thrombosis in the HeartMate II arm. Twenty (20) of the 35 (57%) suspected pump thrombosis events were confirmed.

Figure A.19 Kaplan-Meier Curve for Freedom from Reoperation to Replace or Remove Pump (AT Population)

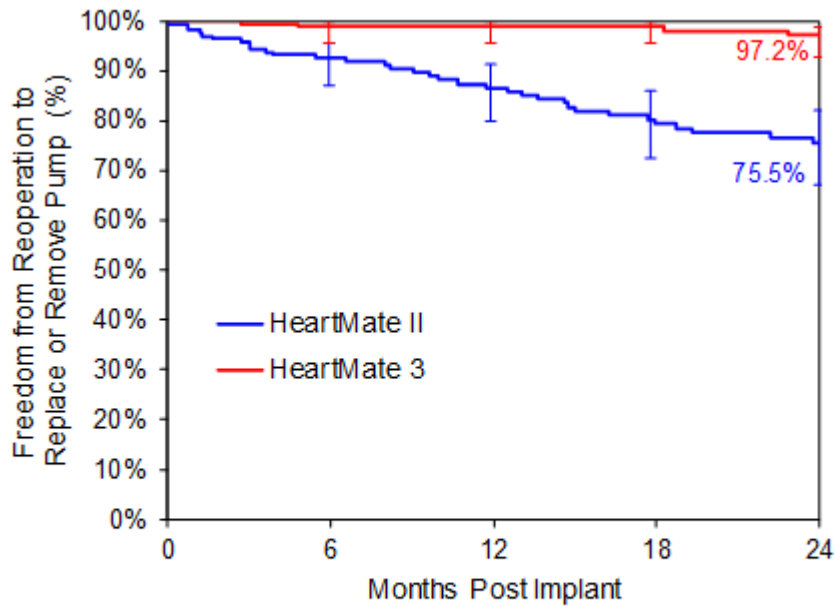

Number of subjects at risk:

HeartMate II	172	135	114	90	76
HeartMate 3	189	164	145	126	114

Note: The confidence intervals were calculated without multiplicity adjustment. The adjusted confidence intervals could be wider than presented here. As such, these confidence intervals are provided to illustrate the variability only and should not be used to draw any statistical conclusion.

	Summary Statistics	
	HeartMate II (n=172)	HeartMate 3 (n=189)
Total Patients	27/172 (16%)	2/189 (1%)
Total Events	33	2
Mean time to first event (days)	195	216
Signs and Symptoms		
Hemolysis	28/33 (85%)	1/2 (50%)
Worsening heart failure	20/33 (61%)	2/2 (100%)
Abnormal pump parameters	18/33 (55%)	2/2 (100%)
Action Taken/Outcome		
Device exchange to assigned study device	16/33 (48%)	0/2 (0%)
Device exchange to non-assigned study device	2/33 (6%)	0/2 (0%)
Device exchange to non-study device	3/33 (9%)	0/2 (0%)
Urgent transplant	4/33 (12%)	0/2 (0%)
Death	4/33 (12%)	0/2 (0%)
Returned Product Assessment Result		
Confirmed	20/33 (61%)	0/2 (0%)
Not confirmed	1/33 (3%)	0/2 (0%)
Inconclusive	3/33 (9%)	0/2 (0%)
Device not returned	9/33 (27%)	2/2 (100%)

Table A.13 Summary of Suspected Device Thrombosis Events (AT Population)

Secondary Endpoints - Long Term Cohort

Adverse Events

Table A.4 lists all the pre-specified adverse events that occurred in the AT population; **Table A.5** lists the serious adverse events only. Serious adverse events are defined as those leading to death, congenital abnormality/birth defect, a life-threatening illness/injury that results in permanent disability, hospitalization/prolonged hospitalization, and/or intervention to prevent permanent injury or damage. All adverse events were adjudicated by the CEC for severity and relatedness to

the device.

Adverse Events	Summary Statistics*	
	HeartMate II (n=172)	HeartMate 3 (n=189)
Major infection	55% (94, 206, 0.85)	55% (104, 217, 0.74)
Localized	35% (60, 114, 0.47)	37% (70, 108, 0.37)
Sepsis	14% (24, 28, 0.12)	14% (26, 37, 0.13)
Driveline	20% (34, 59, 0.24)	24% (45, 68, 0.23)
Pump or pump components	1% (2, 2, 0.01)	0% (0, 0, 0.00)
Pump pocket or pseudo pocket	1% (2, 2, 0.01)	1% (2, 2, 0.01)
Bleeding	52% (90, 206, 0.85)	43% (81, 187, 0.64)
Bleeding requiring surgery	17% (30, 34, 0.14)	12% (23, 29, 0.10)
Gastrointestinal bleeding	27% (47, 100, 0.41)	27% (51, 107, 0.37)
Cardiac arrhythmia	41% (70, 105, 0.43)	38% (71, 108, 0.37)
Ventricular arrhythmia	23% (39, 64, 0.26)	24% (45, 67, 0.23)
Supraventricular arrhythmia	21% (36, 37, 0.15)	18% (33, 40, 0.14)
Both (ventricular and supraventricular arrhythmia)	0% (0, 0, 0.00)	1% (1, 1, 0.00)
Right heart failure	28% (48, 53, 0.22)	32% (60, 73, 0.25)
Right ventricular assist device (RVAD)	5% (8, 8, 0.03)	3% (6, 6, 0.02)
Respiratory failure	23% (39, 46, 0.19)	24% (45, 61, 0.21)
Renal dysfunction	11% (18, 18, 0.07)	13% (25, 29, 0.10)

Table A.14 All Adverse Events at 24 Months (AT Population)

Adverse Events	Summary Statistics*	
	HeartMate II (n=172)	HeartMate 3 (n=189)
Stroke	19% (33, 43, 0.18)	10% (19, 22, 0.08)
Hemorrhagic stroke	9% (16, 17, 0.07)	4% (8, 8, 0.03)
Ischemic stroke	13% (23, 26, 0.11)	6% (12, 14, 0.05)
Debilitating stroke	5% (9, 11, 0.05)	7% (13, 15, 0.05)
Other neurological event	9% (15, 16, 0.07)	12% (22, 25, 0.09)
Encephalopathy	2% (3, 3, 0.01)	3% (6, 6, 0.02)
Seizure	2% (3, 3, 0.01)	3% (5, 5, 0.02)
Transient ischemic attack (TIA)	4% (6, 6, 0.02)	3% (6, 8, 0.03)
Other†	2% (3, 4, 0.02)	3% (6, 6, 0.02)
Hepatic dysfunction	4% (7, 7, 0.03)	4% (8, 8, 0.03)
Psychiatric episode	7% (12, 16, 0.07)	5% (10, 13, 0.04)
Venous thromboembolism	4% (7, 7, 0.03)	5% (10, 11, 0.04)
Hypertension	12% (20, 25, 0.10)	6% (11, 17, 0.06)
Arterial non-CNS thromboembolism	3% (5, 5, 0.02)	2% (4, 4, 0.01)
Pericardial fluid collection	5% (9, 10, 0.04)	2% (4, 5, 0.02)
Myocardial infarction	1% (2, 2, 0.01)	1% (1, 1, 0.00)
Wound dehiscence	1% (2, 2, 0.01)	1% (2, 2, 0.01)
Hemolysis (not associated with suspected device thrombosis)	2% (3, 3, 0.01)	1% (1, 1, 0.00)
Suspected device thrombosis	16% (27, 33, 0.14)	1% (2, 2, 0.01)
Other adverse events	56% (97, 215, 0.89)	70% (133, 332, 1.14)

*% patients (# patients, # events, events/patient-year)

†Other includes anoxic brain injury, traumatic brain injury, and intracranial bleed due to trauma.

Table A.14 All Adverse Events at 24 Months (AT Population)

Adverse Events	Summary Statistics*	
	HeartMate II (n=172)	HeartMate 3 (n=189)
Major infection	50% (86, 178, 0.74)	50% (94, 182, 0.62)
Localized	31% (53, 98, 0.40)	33% (63, 87, 0.30)
Sepsis	14% (24, 28, 0.12)	14% (26, 37, 0.13)
Driveline	16% (27, 47, 0.19)	20% (38, 55, 0.19)
Pump or pump components	1% (2, 2, 0.01)	0% (0, 0, 0.00)
Pump pocket or pseudo pocket	1% (2, 2, 0.01)	1% (2, 2, 0.01)
Bleeding	51% (87, 196, 0.81)	41% (78, 172, 0.59)
Bleeding requiring surgery	17% (30, 34, 0.14)	12% (23, 29, 0.10)
Gastrointestinal bleeding	27% (47, 97, 0.40)	27% (50, 105, 0.36)
Right heart failure	28% (48, 53, 0.22)	32% (60, 73, 0.25)
Right ventricular assist device (RVAD)	5% (8, 8, 0.03)	3% (6, 6, 0.02)
Cardiac arrhythmia	37% (63, 93, 0.38)	33% (63, 94, 0.32)
Ventricular arrhythmia	23% (39, 64, 0.26)	24% (45, 67, 0.23)
Supraventricular arrhythmia	14% (24, 25, 0.10)	12% (22, 26, 0.09)
Both (ventricular and supraventricular arrhythmia)	0% (0, 0, 0.00)	1% (1, 1, 0.00)
Respiratory failure	23% (39, 46, 0.19)	24% (45, 61, 0.21)
Renal dysfunction	11% (18, 18, 0.07)	13% (25, 29, 0.10)
Stroke	19% (33, 43, 0.18)	10% (19, 22, 0.08)

Table A.15 Serious Adverse Events at 24 Months (AT Population)

Adverse Events	Summary Statistics*	
	HeartMate II (n=172)	HeartMate 3 (n=189)
Hemorrhagic stroke	9% (16, 17, 0.07)	4% (8, 8, 0.03)
Ischemic stroke	13% (23, 26, 0.11)	6% (12, 14, 0.05)
Debilitating stroke	5% (9, 11, 0.05)	7% (13, 15, 0.05)
Other neurological event	9% (15, 16, 0.07)	12% (22, 25, 0.09)
Encephalopathy	2% (3, 3, 0.01)	3% (6, 6, 0.02)
Seizure	2% (3, 3, 0.01)	3% (5, 5, 0.02)
Transient ischemic attack (TIA)	4% (6, 6, 0.02)	3% (6, 8, 0.03)
Other†	2% (3, 4, 0.02)	3% (6, 6, 0.02)
Hepatic dysfunction	4% (7, 7, 0.03)	4% (8, 8, 0.03)
Venous thromboembolism	4% (7, 7, 0.03)	4% (8, 9, 0.03)
Psychiatric episode	6% (11, 12, 0.05)	3% (6, 9, 0.03)
Arterial non-CNS thromboembolism	3% (5, 5, 0.02)	2% (4, 4, 0.01)
Hypertension	5% (8, 9, 0.04)	4% (8, 9, 0.03)
Pericardial fluid collection	5% (8, 9, 0.04)	2% (4, 5, 0.02)
Myocardial infarction	1% (2, 2, 0.01)	1% (1, 1, 0.00)
Wound dehiscence	1% (2, 2, 0.01)	1% (2, 2, 0.01)
Hemolysis (not associated with suspected device thrombosis)	2% (3, 3, 0.01)	1% (1, 1, 0.00)
Suspected device thrombosis	16% (27, 33, 0.14)	1% (2, 2, 0.01)
Other adverse events	54% (93, 196, 0.81)	67% (126, 296, 1.02)

*% patients (# patients, # events, events/patient-year)

†Other includes anoxic brain injury, traumatic brain injury, and intracranial bleed due to trauma.

Table A.15 Serious Adverse Events at 24 Months (AT Population)

Stroke

The Kaplan-Meier curve for freedom from stroke is shown in **Figure A.20**.

Figure A.20 Kaplan-Meier Curve for Freedom from Stroke (AT Population)

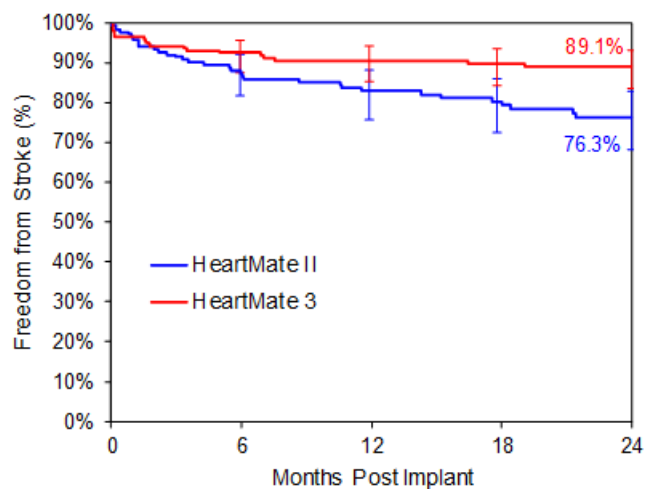

Number of subjects at risk	
HeartMate II	172 127 104 85 73
HeartMate 3	189 159 138 120 111

Note: The confidence intervals were calculated without multiplicity adjustment. The adjusted confidence intervals could be wider than presented here. As such, these confidence intervals are provided to illustrate the variability only and should not be used to draw any statistical conclusion.

A summary of the stroke events within 24 months post implantation is presented in **Table A.16**. Ten percent (10%) of the HeartMate 3 and 19% of the HeartMate II subjects experienced at least one stroke event; however, some subjects experienced more than one stroke event. Among all stroke events that occurred with HeartMate 3, 68% (15/22) were debilitating, as compared to 26% (11/43) of HeartMate II stroke events.

	HeartMate II (n=172)	HeartMate 3 (n=189)
Total Subject with Stroke	33/172 (19.2%)	19/189 (10.1%)
Hx of stroke or TIA	9/33 (27%)	6/19 (32%)
Hx of atrial fibrillation	12/33 (36%)	11/19 (58%)
Total Stroke Events	43	22
Ischemic	26/43 (60%)	14/22 (64%)
Hemorrhagic	17/43 (40%)	8/22 (36%)

	HeartMate II (n=172)	HeartMate 3 (n=189)
Debilitating (MRS > 3)	11/43 (26%)	15/22 (68%)
INR Level		
Subtherapeutic INR (INR < 2.0)	16/34 (47%)	12/18 (67%)
Supratherapeutic INR (INR > 3.0)	8/34 (24%)	0/18 (0%)

Table A.16 Summary of Strokes within 24 months Post Implant (AT Population)

Device Malfunctions

At 24 months, 86 of the 189 (46%) HeartMate 3 patients reported 143 suspected device malfunctions; 62 of the 172 (36%) HeartMate II patients reported 96 suspected device malfunctions, as summarized in **Table A.17**. The majority of suspected malfunctions in both arms involved external components, most commonly the System Controller. Among the total number of suspected device malfunctions at 24 months, the suspected malfunction events of implanted components were more frequent in HeartMate II (26/96, 27%) than in HeartMate 3 (12/143, 8%), while those of external components were more frequent in HeartMate 3 (131/143, 92%) than in HeartMate II (70/96, 73%), as summarized in **Table A.18**.

	Device Malfunctions*		
	#Patients	%Patients	#Events
HeartMate II (n=172)	62 (50)	36% (29%)	96 (75)
HeartMate 3 (n=189)	86 (70)	46% (37%)	143 (107)

*Suspected (confirmed)

Table A.17 Suspected Device Malfunctions at 24 Months

	Device Malfunctions*					
	Implanted Components			External Components		
	#Patients	%Patients	#Events	#Patients	%Patients	#Events
HeartMate II (n=172)	23 (19)	13% (11%)	26 (22)	49 (38)	28% (22%)	70 (53)
HeartMate 3 (n=189)	12 (7)	6% (4%)	12 (7)	79 (65)	42% (34%)	131 (100)

*Suspected (confirmed)

Table A.18 Device Malfunctions by Implanted and External Components at 24 Months

The characterizations of the 143 suspected HeartMate 3 device malfunctions are shown in **Figure A.21**.

Figure A.21 Suspected HeartMate 3 LVAS Malfunctions

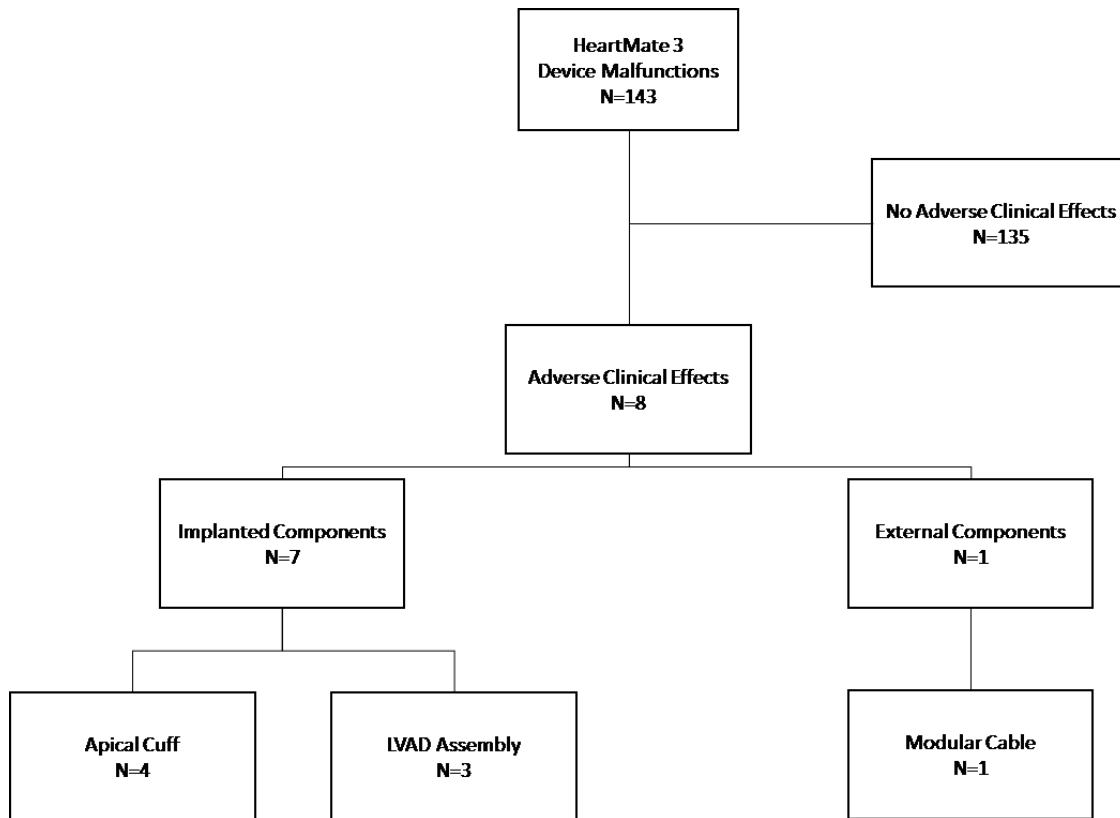

Rehospitalizations

In the AT analysis population, 93% (160/172) of the HeartMate II subjects and 94% (177/189) of the HeartMate 3 subjects were discharged from the hospital following implant surgery, as shown in **Table A.19**. Among discharged subjects, 147 (91.9%) HeartMate II subjects and 156 (88.1%) HeartMate 3 subjects required hospital readmission during their 2-year follow-up period.

	# Subjects Discharged Post Implant	# Subjects Readmitted	% Readmission	# Readmissions
HeartMate II (n=172)	160	147	91.9%	545
HeartMate 3 (n=189)	177	156	88.1%	579

Table A.19 Hospital Readmissions within 24 Months Post Implantation (AT Population)

The reasons for the readmissions are shown in **Table A.20**. Readmission for the management of defined adverse events accounted for a majority of rehospitalizations in both arms (74.1% HeartMate II vs. 74.4% HeartMate 3).

	HeartMate II (n=172)	HeartMate 3 (n=189)
Adverse Event	404	431
Alarms	3	6
Anticoagulation Maintenance	8	19
Other	58	55
Pain	8	8
Routine or Scheduled Testing	5	5
Suspected Device Malfunction	15	5
Transplant or Transplant Evaluation	38	41
Weaning Protocol	0	2
Worsening Heart Failure	6	7
Total	545	579

Table A.20 Reasons for Readmission (AT Population)

The time-to-event analysis of rehospitalization is shown in **Figure A.22**.

Figure A.22 Rehospitalization Following Discharge from Implantation Surgery

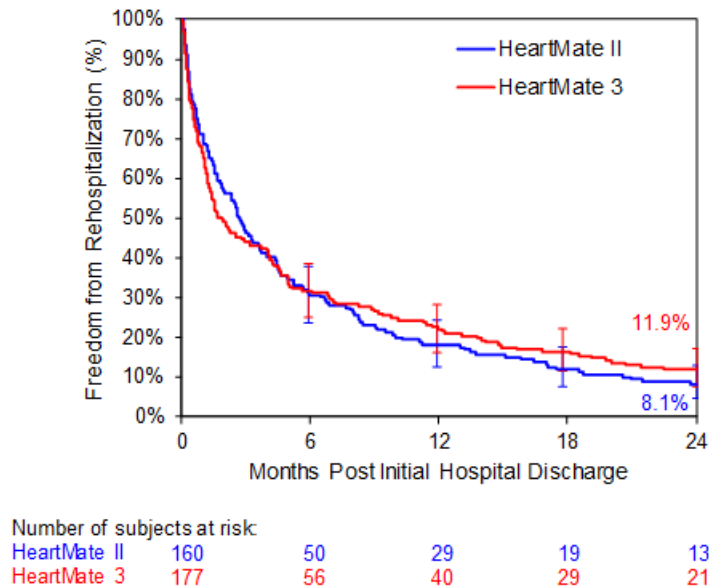

Note: The confidence intervals were calculated without multiplicity adjustment. The adjusted confidence intervals could be wider than presented here. As such, these confidence intervals are provided to illustrate the variability only and should not be used to draw any statistical conclusion.

Reoperations

All surgical procedures that occurred after the initial implantation surgery are summarized in **Table A.6**. Cardiac transplants due to device malfunctions are included as a reoperation; elective cardiac transplants are not. Forty-three percent (43%; 82/189) of HeartMate 3 subjects and 56% (97/172) of HeartMate II subjects required at least one reoperation by 24 months post implantation. Secondary mediastinal procedures and device-related infection management procedures were most common and with similar rates in both arms. Device exchange or removal (urgent transplant) were observed more frequently in HeartMate II subjects.

Two subjects in the HeartMate 3 arm required reoperation because of outflow graft twisting that became clinically evident with low flow alarms on post-operative day 567 and 687, respectively.

Operation	HeartMate II	HeartMate 3
Replace / exchange device	24	3
LVAD Implant (other than HeartMate 3 or HeartMate II)	4	0
Outflow graft replacement	0	1
Heart transplant due to device malfunction	8	0
Device explant	2	1
Chest or abdominal related		
Delayed chest closure	10	22
Mediastinal exploration or evacuation	37	26
Other abdominal or chest exploration	6	3
Gastrointestinal related		
Surgery for gastrointestinal bleeding	5	8
Other gastrointestinal surgery	11	9
Cardiovascular related		
Pericardial fluid collection	6	1
Valve or vascular surgery	13	13
RVAD implant or removal	10	12
Infection related		
Tissue debridement or wound management	27	6
Driveline surgery	17	26
Miscellaneous		
Respiratory surgery	13	14
ICD revision or replacement	9	19

Table A.21 Reoperations at 24 Months (AT Population)

Operation	HeartMate II	HeartMate 3
Orthopedic surgery	8	1
Other*	16	13
Total	226	178
*Includes aborted heart transplant (n=1), biopsy (n=4), craniotomy (n=3), dialysis catheter implant (n=1), eye surgery (n=5), genitourinary surgery (n=4), hematoma evacuation (n=2), hernia repair (n=6), and oral surgery (n=3).		

Table A.21 Reoperations at 24 Months (AT Population)

At 24-month follow-up, the percent of days out of a hospital were similar between HeartMate 3 and HeartMate II subjects (90.3% vs. 91.4%), as shown in **Table A.22**.

	N	Total Days of Support	Index Hospitalization	Rehospitalization Days	Days Out of Hospital	% Days Out of Hospital
HeartMate II	172	88420	3564	4995	79861	90.3%
HeartMate 3	189	106481	4835	4315	97331	91.4%

Table A.22 Days Spent In and Out of the Hospital at 24 months Post Implant (AT Population)

Functional Status

Functional status was assessed by NYHA classification and the 6MWT. Ninety-six percent (96%) of subjects were in NYHA Class IV at baseline. HeartMate 3 and HeartMate II subjects experienced a similar and durable improvement in symptomatology to predominantly Class I or II after LVAD implantation, as shown in **Figure A.6**.

Figure A.23 NYHA Class over Time

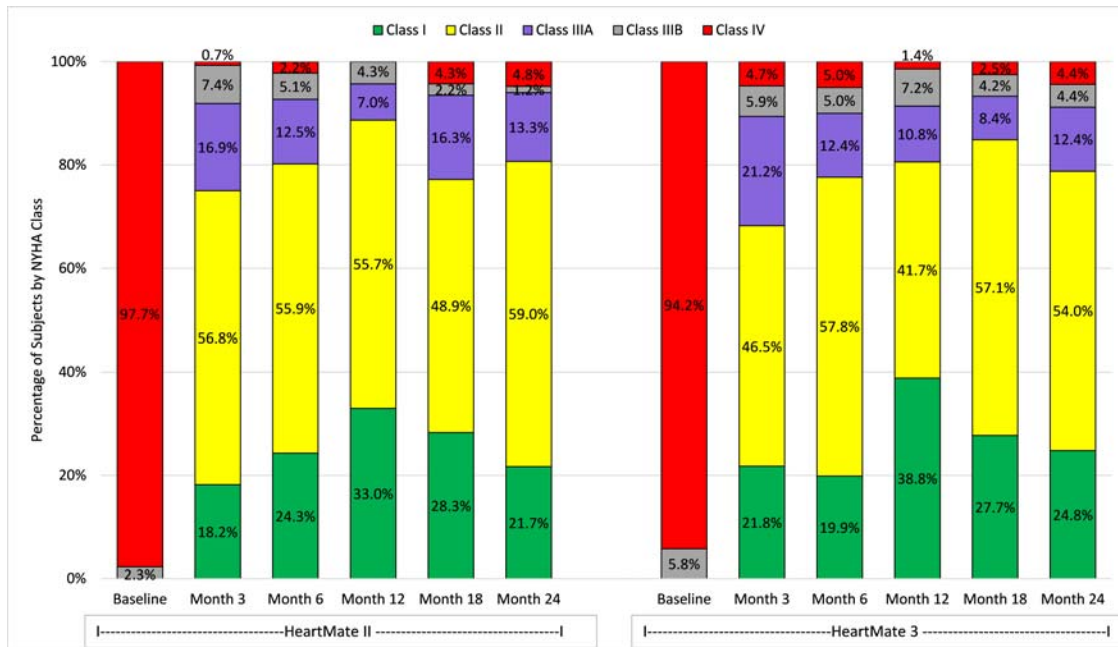

Durable clinically significant improvement in 6MWT was also observed in both arms, as shown in **Figure A.7**. Baseline 6MWT data were unavailable for approximately half of the subjects in both arms and were imputed as being 0. Similar proportions of subjects completed 6MWT evaluations at scheduled post-implantation follow-ups.

Figure A.24 Six-Minute Walk Test over Time (least-squared means, linear mixed model)

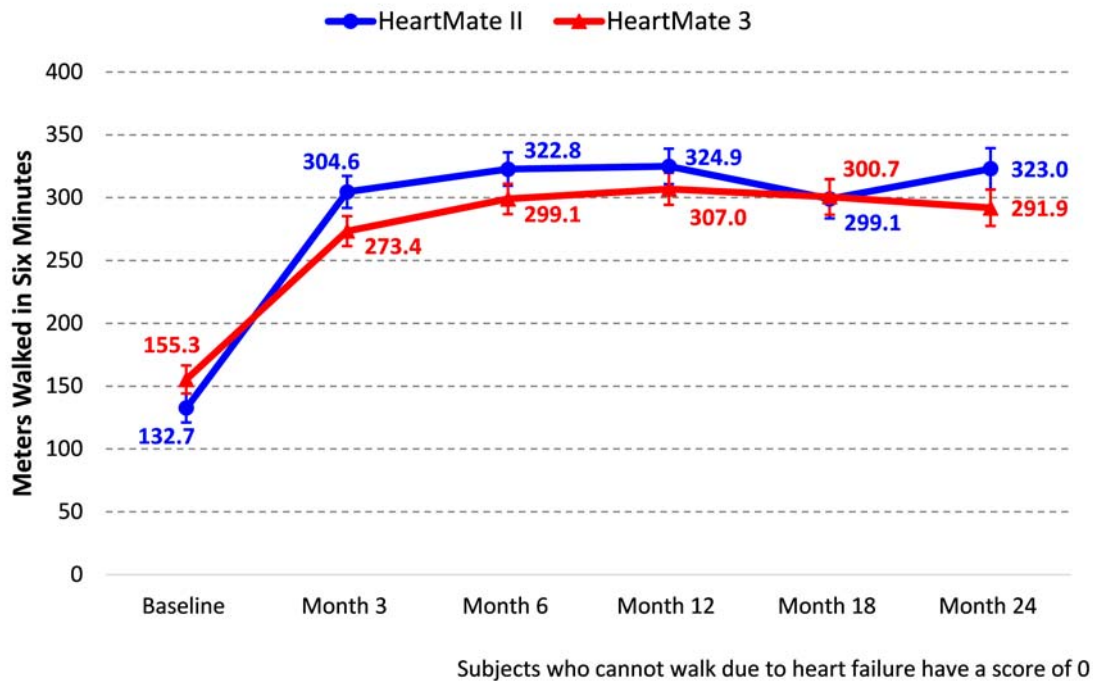

Quality of Life

Quality of life was assessed by the EQ-5D-5L and the KCCQ questionnaires, as summarized in **Figure A.8**, **Figure A.9**, **Figure A.10** and **Figure A.11**. Subjects in both arms showed comparable improvements in the total EQ-5D-5L Score, the EQ-5D-5L Visual Analog Score, the KCCQ Overall Summary Score, and the KCCQ Clinical Summary Score over time.

Figure A.25 Total EQ-5D-5L Score over Time (AT Population)

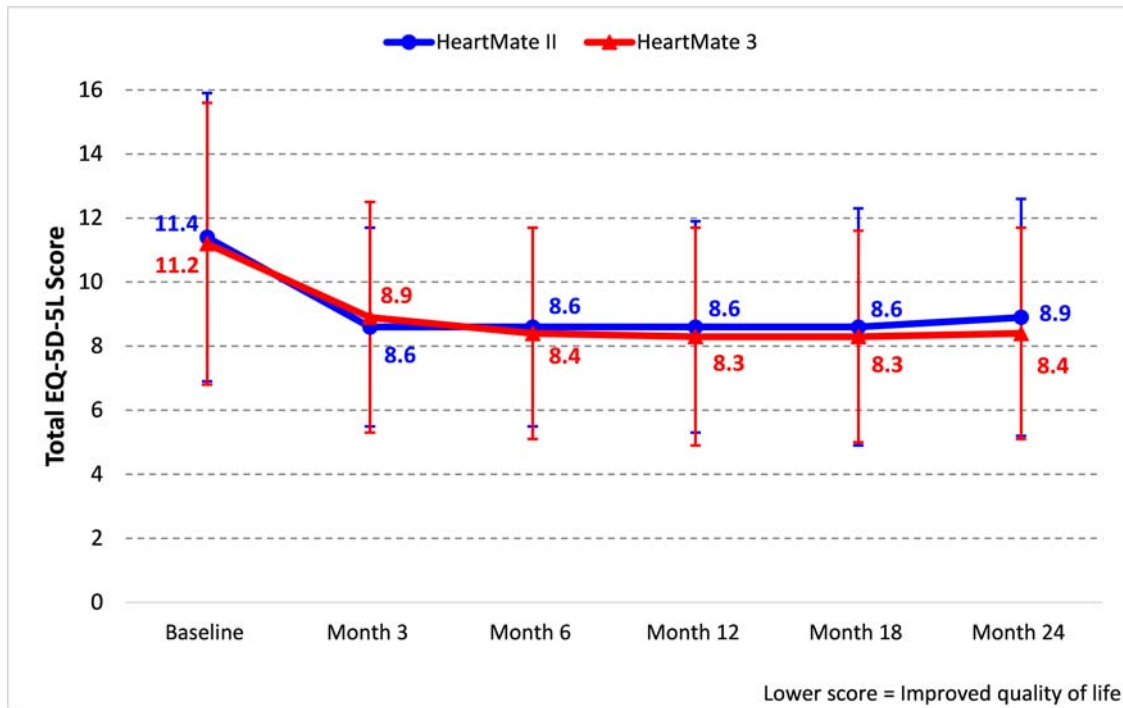

Figure A.26 EQ-5D-5L Visual Analog Score over Time (AT Population)

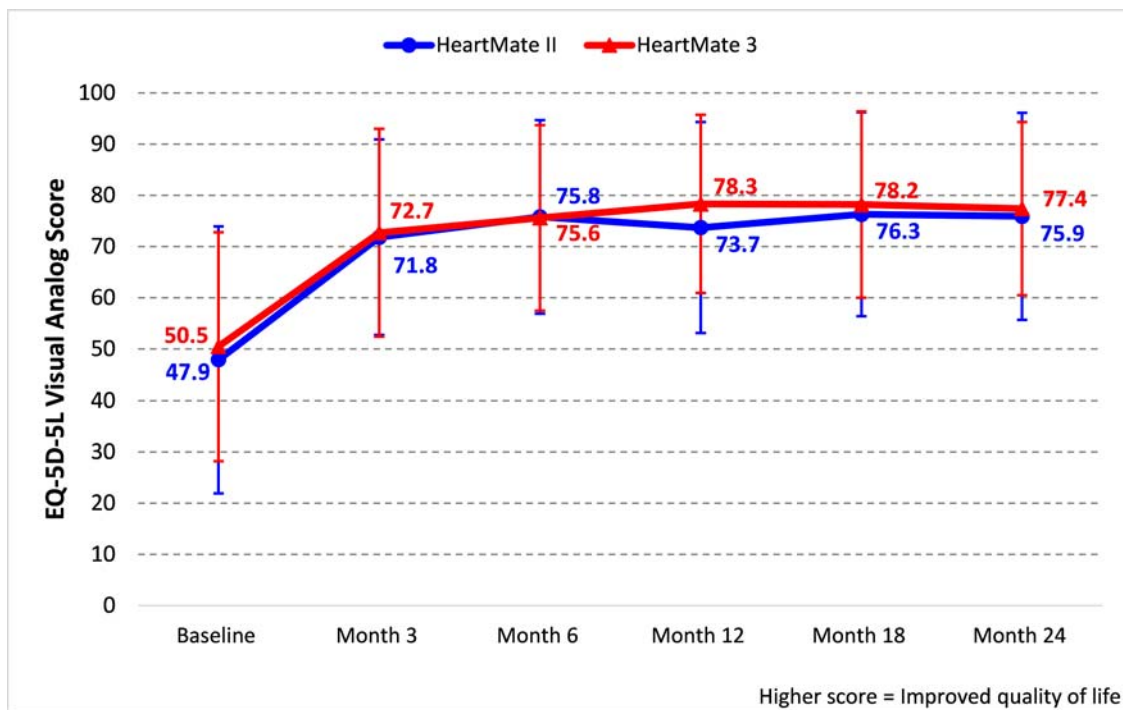

Figure A.27 KCCQ Overall Summary Score over Time (AT Population)

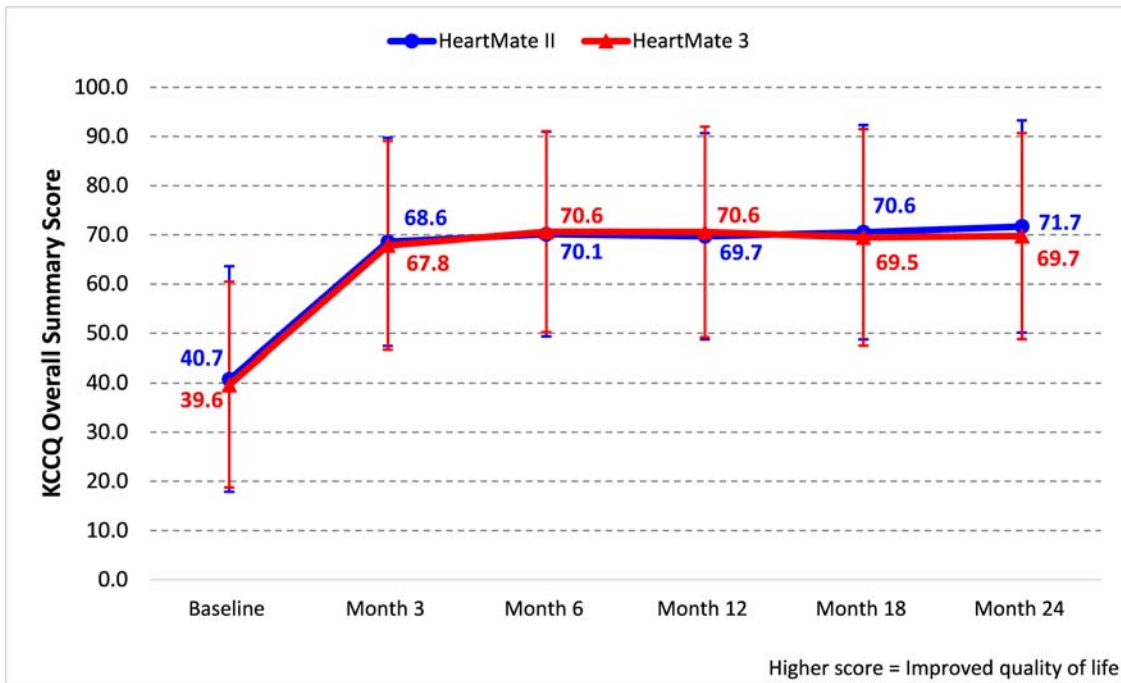
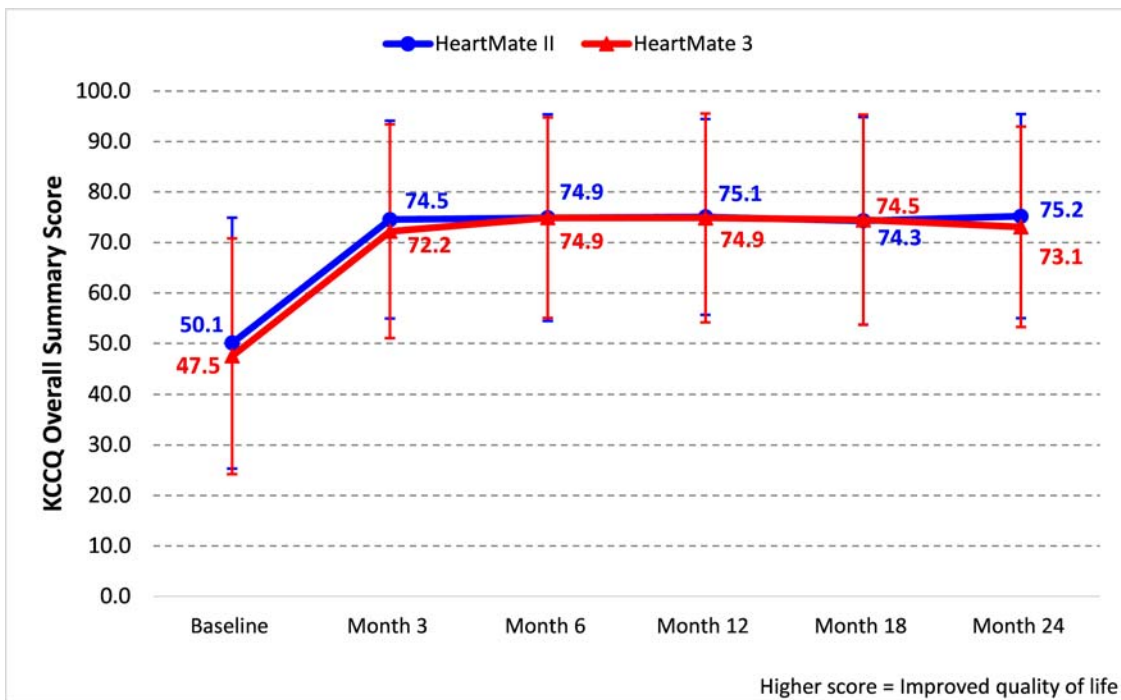

Figure A.28 KCCQ Clinical Summary Score over Time (AT Population)



Competing Outcomes Analysis

Plots of the competing outcomes (ongoing on LVAS support, expiration, transplantation, exchanged to non-study device) are provided in **Figure A.29** and **Figure A.30** for the HeartMate II LVAS and HeartMate 3 LVAS, respectively.

Figure A.29 Competing Outcomes of HeartMate II Patients at 24 Months

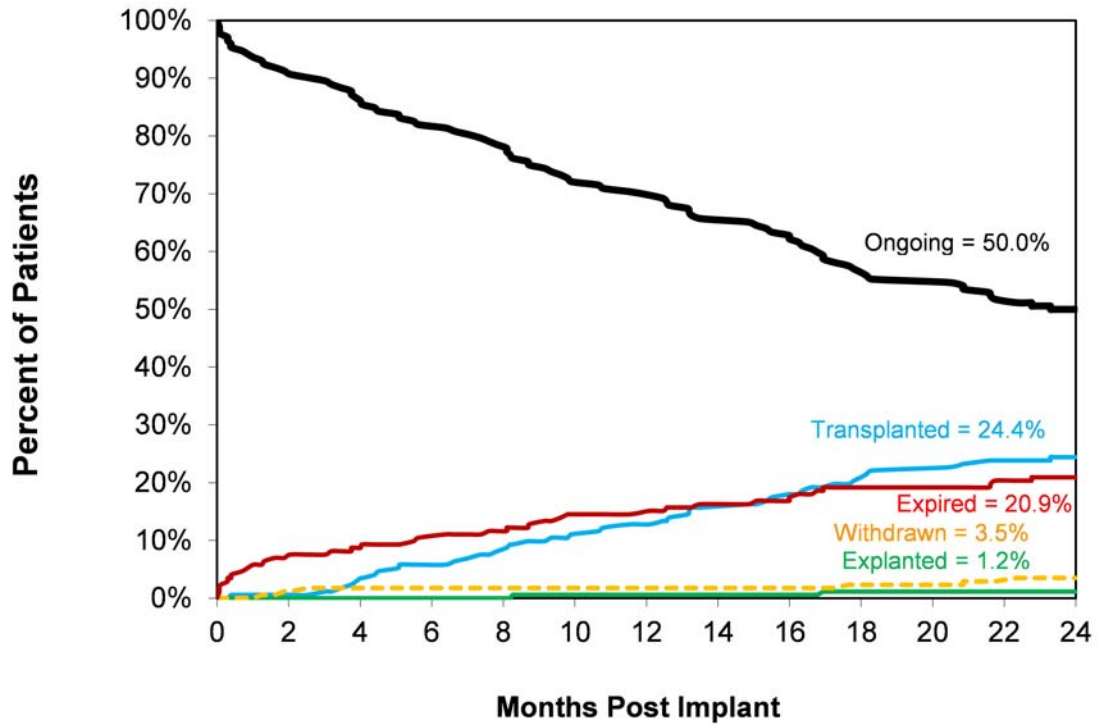
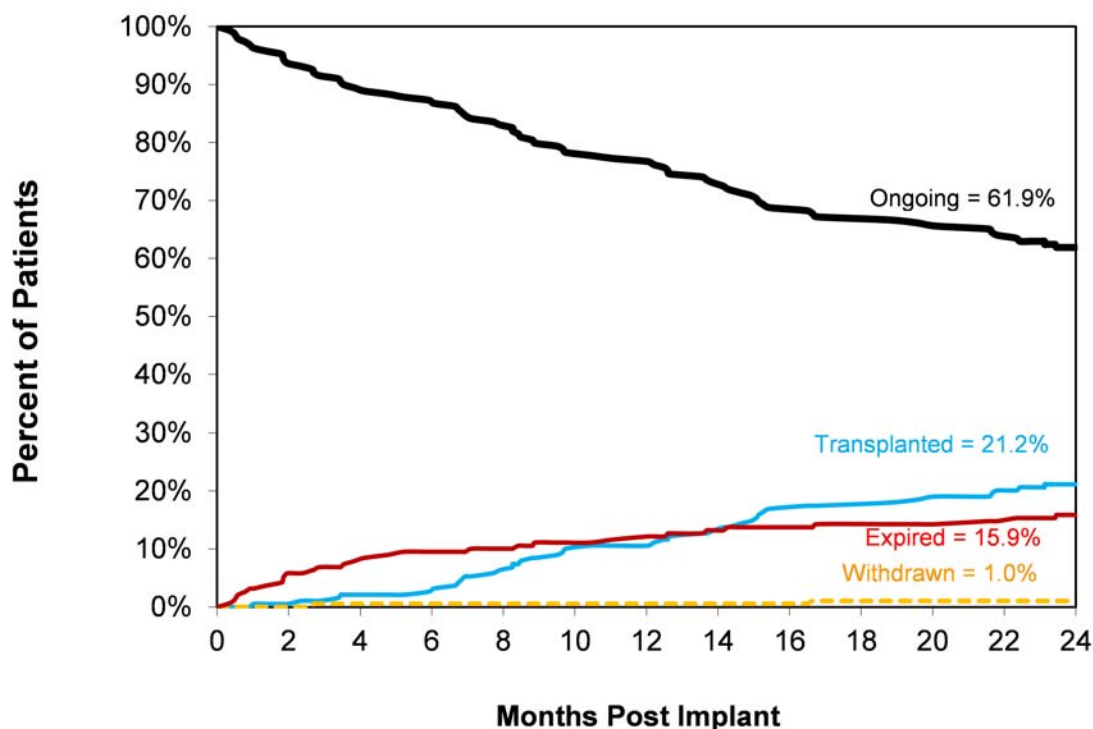

Figure A.30 Competing Outcomes of HeartMate 3 Patients at 24 Months



Subgroup Analyses

Subgroup analysis of the primary endpoint was pre-specified for age, gender, race, intended use, and INTERMACS profile. The results for the ITT and AT populations are shown in **Table A.23** and **Table A.24**, respectively.

Variable	Subgroup	Primary Endpoint Success*	
		HeartMate II (n=176)	HeartMate 3 (n=190)
Age	18 - 59	52/84 (62%)	59/70 (84%)
	60 - 69	34/53 (64%)	62/75 (83%)
	70+	20/39 (51%)	30/45 (67%)
Gender	Male	89/143 (62%)	119/150 (79%)
	Female	17/33 (52%)	32/40 (80%)
Race	Caucasian	81/131 (62%)	96/127 (76%)
	Non-Caucasian	25/45 (56%)	55/63 (87%)

Variable	Subgroup	Primary Endpoint Success*	
		HeartMate II (n=176)	HeartMate 3 (n=190)
Intended Use	BTT/BTC	47/70 (67%)	65/79 (82%)
	DT	59/106 (56%)	86/111 (77%)
INTERMACS Profile [†]	INTERMACS 2 or 3	89/142 (63%)	132/162 (81%)
	INTERMACS 4 or 5	16/30 (53%)	18/26 (69%)

*No. of patients counted as a study endpoint success/no. of patients in subgroup (%).

[†]One (1) HeartMate 3 subject and two (2) HeartMate II subjects were INTERMACS I.

Table A.23 Subgroup Analysis of the Primary Endpoint (ITT Population)

Variable	Subgroup	Primary Endpoint Success*	
		HeartMate II (n=172)	HeartMate 3 (n=189)
Age	18 - 59	52/83 (63%)	59/69 (86%)
	60 - 69	34/50 (68%)	62/75 (83%)
	70+	20/39 (51%)	30/45 (67%)
Gender	Male	89/140 (64%)	119/149 (80%)
	Female	17/32 (53%)	32/40 (80%)
Race	Caucasian	81/129(63%)	96/126 (76%)
	Non-Caucasian	25/43 (58%)	55/63 (87%)
Intended Use	BTT/BTC	47/66 (71%)	65/78 (83%)
	DT	59/106 (56%)	86/111 (77%)
INTERMACS Profile [†]	INTERMACS 2 or 3	89/141 (63%)	132/162 (81%)
	INTERMACS 4 or 5	16/29 (55%)	18/26 (69%)

*No. of patients counted as a study endpoint success/no. of patients in subgroup (%).

[†]One (1) HeartMate 3 subject and two (2) HeartMate II subjects were INTERMACS I.

Table A.24 Subgroup Analysis of the Primary Endpoint (AT Population)

Subgroup analyses of the adverse events were also pre-specified for age, gender, race, intended use, and INTERMACS profile. The results for debilitating stroke and gastrointestinal bleeding are summarized in **Table A.25** and **Table A.26**, respectively.

Variable	Subgroup	Debilitating Strokes*	
		HeartMate II (n=172)	HeartMate 3 (n=189)
Age	18 - 59	4/83 (5%)	0/69 (0%)
	60 - 69	2/50 (4%)	8/75 (10%)
	70+	3/39 (8%)	5/45 (11%)
Gender	Male	7/140 (5%)	9/149 (6%)
	Female	2/32 (6%)	4/40 (10%)
Race	Caucasian	6/129(5%)	10/126 (8%)
	Non-Caucasian	3/43 (7%)	3/63 (5%)
Intended Use	BTT/BTC	1/66 (2%)	5/78 (6%)
	DT	8/106 (8%)	8/111 (7%)
INTERMACS Profile†	INTERMACS 2 or 3	8/141 (6%)	11/162 (7%)
	INTERMACS 4 or 5	1/29 (3%)	2/26 (8%)

*No. of patients with debilitating strokes/no. of patients in subgroup (%).

†One (1) HeartMate 3 subject and two (2) HeartMate II subjects were INTERMACS I.

Table A.25 Subgroup Analysis of Debilitating Strokes (AT Population)

Variable	Subgroup	GI Bleeding*	
		HeartMate II (n=172)	HeartMate 3 (n=189)
Age	18 - 59	21/83 (25%)	11/69 (15%)
	60 - 69	19/50 (38%)	26/75 (34%)
	70+	7/39 (17%)	14/45 (31%)
Gender	Male	40/140 (28%)	36/149 (24%)
	Female	7/32 (21%)	15/40 (37%)
Race	Caucasian	35/129(27%)	34/126 (27%)
	Non-Caucasian	12/43 (27%)	17/63 (27%)

Variable	Subgroup	GI Bleeding*	
		HeartMate II (n=172)	HeartMate 3 (n=189)
Intended Use	BTT/BTC	14/66 (21%)	15/78 (19%)
	DT	33/106 (31%)	36/111 (32%)
INTERMACS Profile†	INTERMACS 2 or 3	41/141 (29%)	43/162 (26%)
	INTERMACS 4 or 5	6/29 (20%)	8/26 (30%)

*No. of patients with GI bleeding/no. of patients in subgroup (%).

†One (1) HeartMate 3 subject and two (2) HeartMate II subjects were INTERMACS I.

Table A.26 Subgroup Analysis of Gastrointestinal Bleeding (AT Population)

Summary Of The Study Results - Long Term

Long Term Cohort

The results of the LT Cohort analysis show that the HeartMate 3 LVAS is superior to the HeartMate II LVAS when used for the treatment of patients with advanced refractory left ventricular heart failure as assessed by the primary endpoint of survival free of debilitating stroke or reoperation to replace the pump at two years. The superiority was mostly driven by a higher incidence of suspected pump thrombosis in the HeartMate II LVAS arm. Subjects in both arms of the trial demonstrated significant improvement in functional status and quality of life compared to pre-implant baseline.

TECHNICAL SPECIFICATIONS

This section provides the technical specifications for the HeartMate 3™ Left Ventricular Assist System.

Specifications

The technical specifications for the HeartMate 3™ Left Ventricular Assist System are listed here. For ordering information and catalog numbers, see *HeartMate 3™ Product List* on page D-1.

HeartMate 3™ Left Ventricular Assist System Implant Kit

BLOOD VOLUMES-FLUID CAPACITY

Dimensions (pump body)	
Diameter	50.3 mm (2.0 in)
Height	55.8 mm (2.2 in) Includes Inflow Cannula 33.8 mm (1.3 in) Excludes Inflow Cannula
Weight (pump body)	200 g (7.0 oz)
Displaced Volume	80 cc (4.9 cu in)
Priming Volume	21 cc (1.3 cu in)

BLOOD CONTACTING SURFACES

Titanium	Fused titanium microspheres
Sealed Outflow Graft	Gelatin-impregnated woven polyester
Inflow Cannula	Integrated titanium with fused titanium microspheres

CONSTRUCTION

Outer Shell	Titanium
Apical Cannula	20.5 mm (0.8 in.) titanium
Apical Cuff	PTFE Felt with integrated locking ring
Sealed Outflow Graft	Gelatin-impregnated 14 mm woven polyester, with 10.0N attachment force to the Pump
Electric Line	6-conductor silicone sheath - 2 piece Driveline (Pump Cable connected to the Modular Cable via an inline modular connection)

PERFORMANCE DATA

Power Consumption	4 watts nominal
Operating Voltage	10–17 Volts DC
Pump Speed Range	3,000–9,000 rpm
Minimum Pump Speed	3,000 rpm

Sterile HeartMate 3™ System Controller

ACTIVE FUNCTIONS

- Monitoring of System Performance
 - Communication with implanted LVAD
 - Communication with Tablet for use with the HeartMate Touch App (via the Power Module and HeartMate Touch Wireless Adapter)
-

OPERATING MODES

Run Mode	Connected to LVAD
Charge Mode	No LVAD Connected for Backup Battery Charging
Sleep Mode	Internal Clock Maintenance
Power Saver Mode	During low battery hazard operation

MONITORING FUNCTIONS

Fault detection and alarms
Performance data processing and storage
Battery state-of-charge indicators and alarms
LVAD Status
Driveline continuity check
Backup battery charge status

ALARM SOUND PRESSURE LEVEL (SPL)

Hazard Alarms: 85 dB 2300 Hz ± 300 Hz
Advisory Alarms: 85 dB 2300 Hz ± 300 Hz

DIMENSIONS

Length	12.7 cm (5 in)
Width	3.5 cm (1.375 in)
Height	8.0 cm (3.125 in)

WEIGHT	336 g (12 oz)
---------------	---------------

PRODUCT LIFE	Product meets testing standards for use for at least three years from date of first use
---------------------	---

11 Volt Lithium-Ion Backup Battery

PERFORMANCE DATA	
Type	11 Volt Lithium-Ion
Capacity	12.2 watt-hour
Discharge Time	15 minutes at 10 Watts (pump speed = 9,000rpm, flow = 10.0 L/min)
Charge Time	3 hours maximum, with a minimum voltage of 13.0V
DIMENSIONS	
Length	7.1 cm (2.8 in)
Width	5.1 cm (2 in)
Height	1.5 cm (0.6 in)
WEIGHT	
	84.6 g (2.98 oz)
PRODUCT LIFE	
	Product meets testing standards for use for 10950 cumulative discharge minutes, as tracked by the System Controller and reported on the HeartMate Touch™ Communication System, or 3 years from the date of manufacture, whichever comes first.

HeartMate Touch Wireless Adapter

ACTIVE FUNCTIONS

Facilitates Bluetooth® pairing of the Tablet for use with the HeartMate Touch App to the Power Module.

DIMENSIONS

Length	7.6 cm (3 in)
--------	---------------

Width	5.1 cm (2 in)
-------	---------------

Height	5.1 cm (2 in)
--------	---------------

WEIGHT	45.4 g (1.6 oz)
---------------	-----------------

PRODUCT LIFE	At least 3 years.
---------------------	-------------------

RADIO DECLARATIONS – HeartMate Touch Wireless Adapter

Contains FCC ID: TFB-1005

Modifications made to the product, unless expressly approved by Thoratec, could void the user's authority to operate the equipment.

CAUTION !

To comply with FCC and Industry Canada RF radiation exposure limits for general population, the Touch Wireless Adapter must be installed such that a minimum separation distance of 20 cm (8 in.) is maintained between it and all persons at all times and must not be co-located or operating in conjunction with any other antenna or transmitter.

ISED/IC: Contains IC: 5969A-1005

The term "IC:" before the radio certification number only signifies that Industry Canada technical specifications were met.

WARNING !

This is a Class A product. In a domestic environment this product may cause radio interference in which case the user may be required to take adequate measures.

Power Module

ACTIVE FUNCTIONS

Isolated power to patient during tethered operation

Communication interface between System Controller and HeartMate Touch™ Communication System

When new, AC power failure backup battery (30 minutes to operate HeartMate 3™ Left Ventricular Assist System)

MONITORING FUNCTIONS

Isolated bidirectional data link to external HeartMate Touch Communication System

Isolated dual-channel analog uplink AC power failure alarm

Advisory/Hazard LO BATT alarm for internal backup battery

"Echoes" System Controller Audio Alarm

System Malfunction Alarm (Yellow Wrench)

ALARM SOUND PRESSURE LEVEL (SPL)

Hazard Alarms: 80 dB

Advisory Alarms: 80 dB

POWER REQUIREMENTS

100–240 VAC, 50–60 Hz, 1 A maximum

To isolate the system from the AC wall power, pull the power cord from the wall socket.

FUSE RATING T 2A, 250 V

DIMENSIONS

Length 381 mm (15 in)

Width 254 mm (10 in)

Height 127 mm (5 in)

WEIGHT 4.8 kg (10.5 lb)—with backup battery

PRODUCT LIFE Product meets testing standards for use for at least two years from date of first use

Power Module Patient Cable

TYPE	A cable assembly that has one straight plug connector with sliding interlock and composite strain relief for connecting to the Power Module, and two thread-locking power connectors for connecting to the System Controller
FUNCTION	To provide connection between the System Controller and the Power Module
LENGTH	6.1 m (20 ft)
PRODUCT LIFE	Product meets testing standards for use for at least one year from date of first use

Mobile Power Unit

ACTIVE FUNCTIONS

Isolated power to patient during tethered operation

MONITORING FUNCTIONS

Fault detection and alarms

"Echoes" System Controller Audio Alarm

ALARM SOUND PRESSURE LEVEL (SPL)

Hazard Alarms: 80 dB

Advisory Alarms: 80 dB

POWER REQUIREMENTS

100–240 VAC, 50/60 Hz, 2.0–1.0 A maximum

To isolate the system from the AC wall power, remove the power cord from the wall socket.

DIMENSIONS

Length 18.4 cm (7.25 in)

Width 12.7 cm (5.0 in)

Height 12.7 cm (5.0 in)

CABLE LENGTH 6.1 m (20 ft)

WEIGHT 1.4 kg (3.0 lb) - with three AA (LR6) batteries

PRODUCT LIFE Product meets testing standards for use for at least two years from date of first use

HeartMate™ 14 Volt Lithium-Ion Battery

PERFORMANCE DATA	
Type	14 Volt, Lithium-Ion
Capacity	4.8 amp-hour each or 71 watt-hour
Discharge Time	One pair of new HeartMate™ 14 Volt Lithium-Ion batteries provides 17 hours of support under nominal operating conditions for a HeartMate 3™ Left Ventricular Assist System (5.4 lpm)
Power Gauge	5-LED, button activated
Charge Time	4 hours maximum (using Battery Charger)
DIMENSIONS	
Length	160 mm (6.3 in)
Width	76 mm (3.0 in)
Height	25 mm (1.0 in)
WEIGHT	0.50 kg (1.1 lb)—System accommodates two batteries
PRODUCT LIFE	Product meets testing standards for use for 360 cycles (as reported when the battery is inserted into a charging pocket of the Battery Charger), or 3 years from the date of manufacture, whichever comes first

14 Volt Lithium-Ion Battery Clip

DIMENSIONS	
Length	80 mm (3.15 in)
Width	92 mm (3.75 in)
Height	32 mm (1.25 in)
WEIGHT	104 g (3.7 oz)—without battery
PRODUCT LIFE	Product meets testing standards for use for at least two years from date of first use

Battery Charger

ACTIVE FUNCTIONS

Four pockets for simultaneous battery charging for HeartMate™ 14 Volt Lithium-Ion batteries

Battery calibration and diagnostics

MONITORING FUNCTIONS

Battery fault monitoring (with alarm codes)

Battery charger fault monitoring (with alarm codes)

POWER REQUIREMENTS

100–240 VAC, 50–60 Hz, 3 A (maximum)

Fuse Rating - T5A, 250 V

DIMENSIONS

Length 370 mm (14.5 in)

Width 216 mm (8.5 in)

Height 227 mm (9 in)

WEIGHT 3.6 kg (8 lb)

PRODUCT LIFE Product meets testing standards for use for at least two years from date of first use

Tablet for use with the HeartMate Touch App

TYPE	iPad [†] with HeartMate Touch App
RESOLUTION	2224-by-1668 resolution at 264 pixels per inch (ppi)
FUNCTION	
Monitor View	<ul style="list-style-type: none"> • Displays speed, flow (lpm), power, pulsatility index (PI). • Displays prioritized alerts and advisories.
Clinical View	<ul style="list-style-type: none"> • Displays speed, flow (lpm), power, pulsatility index (PI). • Displays the primary operating parameters and provides the critical information needed during the surgical procedure.
Historical View	<ul style="list-style-type: none"> • Displays speed, flow (lpm), power, pulsatility index (PI). • Displays the history of the patient's LVAS.
DIMENSIONS	
Height	270 mm (10.63 in)
Width	209.6 mm (8.25 in)
Depth	17.5 mm (0.69 in)
WEIGHT	0.84 kg (1.86 lbs)
PRODUCT LIFE	Tablet for use with the HeartMate Touch App – At least 3 years. Accessories (Power Adapter and USB cable, Flash Drive) – At least 1 year.

USB Power Cable

Use only the Abbott-supplied 2-meter (80 in.) USB to Lightning cable to power or charge the Tablet.

HeartMate™ Consolidated Bag

TYPE	Slim profile shoulder bag for use with HeartMate 3™ Left Ventricular Assist System
FUNCTION	Allows patient to wear and carry HeartMate 3 batteries, battery clips, and System Controller
PRODUCT COMPATIBILITY	For use with: System Controller Batteries Battery Clips
CONFIGURATION	Right-side Driveline exit/right-side wear Left-side Driveline exit/left-side wear
STRENGTH	Accommodates the weight of the batteries, battery clips, and System Controller with a significant safety factor to allow for forces imparted by daily activities
COLOR	Black
SIZE	One size fits most
PRODUCT LIFE	Product meets testing standards for use for at least two years of continuous use

HeartMate™ Shower Bag

TYPE	Water-resistant Shower Bag for use with HeartMate 3™ Left Ventricular Assist System
FUNCTION	Protects external system components from moisture during showering
PRODUCT COMPATIBILITY	For use with: System Controller Batteries Battery Clips Patient Cables
STRENGTH	Accommodates the weight of the batteries, battery clips, and System Controller with a significant safety factor to allow for forces imparted by daily activities
COLOR	Black
SIZE	One size fits most
PRODUCT LIFE	Product meets testing standards for use for at least two years of continuous use

HeartMate™ Battery Holster

TYPE	Battery holder
FUNCTION	Allows patient to wear two HeartMate™ 14 Volt Lithium-Ion batteries close to the body while performing daily activities
PRODUCT COMPATIBILITY	For use with: System Controller Batteries Battery Clips
STRENGTH	Accommodates the weight of the batteries, battery clips, and System Controller with a significant safety factor to allow for forces imparted by daily activities
COLOR	Black
SIZE	One size fits most
PRODUCT LIFE	Product meets testing standards for use for at least two years of continuous use

HeartMate™ Holster Vest

TYPE	Vest
FUNCTION	Allows patient to wear two HeartMate™ 14 Volt Lithium-Ion batteries close to the body while performing daily activities
PRODUCT COMPATIBILITY	For use with: System Controller Batteries Battery Clips
STRENGTH	Accommodates the weight of the batteries, battery clips, and System Controller with a significant safety factor to allow for forces imparted by daily activities
COLOR	Black
SIZES	For small users less than 160 lb (73kg) For medium users 160–240 lb (73–109 kg) For large users greater than 240 lb (109 kg)
PRODUCT LIFE	Product meets testing standards for use for at least two years of continuous use

HeartMate™ Wearable Accessories Kit

TYPE	System Controller Neck Strap, Belt Attachment, and Protection Bag
FUNCTION	<ul style="list-style-type: none"> • System Controller Neck Strap and Belt Attachment provide options for the patient to wear HeartMate 3™ System Controller • Protection Bag protects the backup System Controller and cables when not in use
PRODUCT COMPATIBILITY	For use with HeartMate 3 System Controller
STRENGTH	Each accessory accommodates the weight of the System Controller with a significant safety factor to allow for forces imparted by daily activities
COLOR	Black
SIZE	One size fits most
PRODUCT LIFE	Product meets testing standards for use for at least at least two years of continuous use

HeartMate™ Travel Bag

TYPE	Shoulder Bag
FUNCTION	Provides a convenient way to carry and transport the backup System Controller and spare batteries
PRODUCT COMPATIBILITY	For use with HeartMate 3™ Left Ventricular Assist System
STRENGTH	The Travel Bag accommodates the weight of the batteries and System Controller with a significant safety factor to allow for forces imparted by daily activities.
COLOR	Black
SIZES	One size fits most
PRODUCT LIFE	Product meets testing standards for use for at least at least two years of continuous use

Note: Abbott's product life recommendations are based on testing standards for the typical use of the therapy. Continued use after useful life is not guaranteed by Abbott and component should be considered for replacement for optimal performance. Determination for medical appropriateness of replacement should be determined by a clinician.

SAFETY TESTING AND CLASSIFICATION

This section provides safety testing and classification information for the HeartMate 3 Left Ventricular Assist System.

Safety Testing and Classification - - - - -	C-2
Testing and Classification: HeartMate 3 LVAS - - - - -	C-5
Testing and Classification: Power Module - - - - -	C-6
Testing and Classification: Mobile Power Unit - - - - -	-C-12
Testing and Classification: Battery Charger- - - - -	-C-17
Testing and Classification: HeartMate 14 Volt Lithium-Ion Batteries -	C-24

Safety Testing and Classification

The HeartMate 3 Left Ventricular Assist System has been thoroughly tested and Classified by Underwriters Laboratories, LLC (UL) to the fire, casualty, and electric shock hazard requirements of the following safety standards, as applicable:

- IEC 60601-1:2012 (ed. 3.1)
- IEC 60601-1:2005 + Corr. 1:2006 + Corr. 2:2007 (ed. 3.0)
- IEC 60601-1-11:2015
- IEC 60601-1-8:2006 + A1:2012
- IEC 60601-1-6:2010 + A1:2013
- IEC 62366:2007 + A1:2014

- EN 60601-1:2012 (ed. 3.1)
- EN 60601-1:2006 +Corr. 2:2010 (ed. 3.0)

- ANSI/AAMI ES60601-1:2005/(R)2012 and A1:2012, C1:2009/(R)2012 + A2:2010/(R)2012 (ed. 3.1)
- ANSI/AAMI ES60601-1:2005/(R)2012 and C1:2009/(R)2012 and A2:2010/(R)2012 (ed. 3.0)

- CAN/CSA C22.2 No. 60601-1:14 (ed. 3.1)
- CAN/CSA C22.2 No. 60601-1:08 (ed. 3.0)
- CAN/CSA C22.2 No. 60601-1-11:15

These standards require making the following declarations and stating the type and degree of protection for listed hazards.

- UL 60601-1, 1st ed., 2006-04-26
- CAN/CSA-C22.2 No. 601.1-M90 (R2005)



Medical Electric Equipment
with respect to shock, fire,
mechanical and other specified
hazards only in accordance with
UL 60601-1 and CAN/CSA C22.2
No.601.1-M90 (R1997), CAN/CSA C22.2
No.601.1S1-94, and CAN/CSA-C22.2
No.601.1B-98 (National Difference for Canada)
No.601.1 7D72

Declaration Concerning General Safety Standards

Type	Degree of Protection
Mode of Operation	Continuous/Pulse
Method of Sterilization	100% EtO for blood pump, Controller, and all sterile accessories
Type of protection against electrical shock	Power Module: <ul style="list-style-type: none"> • Class I (grounded) when connected to AC Mains • Class II when connected to Backup Battery Lithium-Ion Batteries: <ul style="list-style-type: none"> • Class II Battery Charger: <ul style="list-style-type: none"> • Class I Mobile Power Unit <ul style="list-style-type: none"> • Class II
Degree of protection against electric shock	Type CF (Cardiac Floating)
Degree of safety of application in the presence of a flammable anesthetic mixture with air or with oxygen or nitrous oxide	Equipment not suitable for use in the presence of a flammable anesthetic mixture with air or with oxygen or nitrous oxide
Degree of protection against harmful ingress of water and particulate matter	<ul style="list-style-type: none"> • System Controller–IP24:Protection against ingress of solid foreign objects the size of a finger and from splashing water • Power Module–IPX0:Non-protected against ingress of water • Tablet for use with the HeartMate Touch App–IPX0:Non-protected against ingress of water • HeartMate Touch Wireless Adapter–IPX0:Non-protected against ingress of water • Shower Bag–IPX3: Protection against ingress of spraying water • 14 V Battery and Clip (only when connected to the System Controller)–IP24: Protection against ingress of solid foreign objects the size of a finger and from splashing water • Battery Charger–IPX0: Non-protected against ingress of water • Mobile Power Unit–IP22: Protection against ingress of solid foreign objects the size of a finger and vertically falling water drops when the enclosure is tilted up to 15°

Table C.1 Declaration Concerning General Safety Standards

Type	Degree of Protection
Applied parts	<ul style="list-style-type: none"> • HeartMate 3 Left Ventricular Assist Device • System Controller
Performance Determined to be Essential Performance	<ul style="list-style-type: none"> • Maintain Pump Speed (Note: Pump Speed is the characteristic that the physician uses to set the desired blood flow.) • Alarm for Pump Speed performance outside of the essential performance limits. • Prevent Leakage in Blood Path.

Table C.1 Declaration Concerning General Safety Standards

Testing and Classification: HeartMate 3 LVAS

The HeartMate 3 Left Ventricular Assist System has been tested and found to comply with the limits for medical devices to the IEC 60601-1-2:2014 Medical electrical equipment - Part 1-2: General requirements for basic safety and essential performance - Collateral Standard: Electromagnetic disturbances - Requirements and tests, with the exception of the Battery Charger, which was tested according to the recommendations of IEC TR 60601-4-2: Medical Electrical Equipment - Part 4-2: Guidance and interpretation - Electromagnetic immunity: performance of medical electrical equipment and medical electrical systems. These limits are designed to provide reasonable protection against harmful interference in a typical medical installation. The HeartMate 3 Left Ventricular Assist System can generate, use, and radiate radio frequency energy and, if not installed and used in accordance with the instructions, may cause harmful interference to other devices in the vicinity. However, there is no guarantee that interference will not occur in a particular installation. If this equipment does cause harmful interference to other devices, the user is encouraged to try to correct the interference by one or more of the following measures:

- Reorient or relocate the equipment.
- Increase the separation between the equipment.
- Connect the equipment into an outlet on a circuit different from that to which the other device(s) are connected.
- Consult Abbott for assistance.

Note: Special precautions are required for installing and using the HeartMate 3 Left Ventricular Assist System within portable and RF communication environments. The HeartMate 3 LVAS and its accessories need special precautions regarding EMC and needs to be put into service according to the EMC information provided in this Instructions for Use.

CAUTION !

Be sure to keep all persons at least 20 cm (8 in.) from the HeartMate Touch Wireless Adapter when on the Power Module.

The HeartMate 3 Left Ventricular Assist System is protected against the effects of external cardiac defibrillation within the limits established per EN 45502-1:1997. However, it is advised that the HeartMate 3 Left Ventricular Assist System be disconnected from the System Controller during the use of open-heart defibrillation.

Testing and Classification: Power Module

Declaration and Guidance for Electromagnetic Disturbances

The HeartMate 3 LVAS (powered by the Power Module) is suitable for use in the following environments:

- Hospitals, including ORs and emergency rooms
- Treatment areas near active HF Surgical equipment.

HEARTMATE 3 LVAS Powered By the Power Module (with HeartMate Touch Communication System)		
EM Disturbance type / Standards	IEC 60601-1-2 (2014) Compliance Level	Use Environment Guidance
RF Emissions / CISPR 11 EN 55011	Group 1, Class A 30 – 1,000 MHz	The HeartMate 3 LVAS with Power Module is not suitable for use in domestic establishments or those directly connected to the public low-voltage power supply (mains) network that supplies domestic (residential) buildings.
Harmonic Emissions / IEC 61000-3-2 EN 61000-3-2	Class A	
Voltage Fluctuations & Flicker Emissions / IEC 61000-3-3 EN 61000-3-3	Complies fully	The HeartMate 3 LVAS with Power Module (PM) and HeartMate Touch Communication System uses RF energy only for its internal purposes and thus have low unintentional RF emissions and is unlikely to cause interference in nearby electronic equipment.
Electrostatic Discharge (ESD) Immunity / IEC 61000-4-2 EN 61000-4-2	±8 kV Contact ±15 kV Air	The relative humidity where the HeartMate 3 LVAS with PM is used should be at least 5%. Higher relative humidity will reduce the severity of ESD events.

Table C.2 Declaration and Guidance Concerning Electromagnetic Disturbances for the Power Module

<p>Radiated RF Immunity / IEC 61000-4-3 EN 61000-4-3</p>	<p>10 V/m 80 MHz – 6.0 GHz 80% AM at 1 kHz</p>	<p>For many common 2-Watt (maximum) transmitters in the 80 MHz to 6.0 GHz range, the following minimum separation distances to the HeartMate 3 LVAS with PM are recommended:</p> <p style="text-align: center;">80 - 800 MHz: 1.7 m (5.7 feet) 800 MHz – 6.0 GHz: 3.3 m (10.8 feet)</p> <p>Note: At 800 MHz, the separation distance for the higher frequency range applies.</p> <p>For many common 10-Watt (maximum) transmitters in the 80 MHz to 6.0 GHz range, the following minimum separation distances to the HeartMate 3 LVAS with PM are recommended:</p> <p style="text-align: center;">80 - 800 MHz: 3.8 m (12.7 feet) 800 MHz – 6.0 GHz: 7.3 m (24.3 feet)</p> <p>Note: At 800 MHz, the separation distance for the higher frequency range applies.</p> <p>Equipment^[a] examples: Garage door remote controls, emergency services radios, “walkie-talkie” radios, Amateur “HAM” radios, Cellular telephone base stations, and RFID readers.</p> <p>Interference to the HeartMate 3 LVAS may occur near equipment or areas that are marked with the following symbol:</p> <p style="text-align: center;"></p> <p>Note: 1,000 MHz = 1.0 GHz</p> <p>[a] – List is not comprehensive.</p>
---	--	---

Table C.2 Declaration and Guidance Concerning Electromagnetic Disturbances for the Power Module

<p>Portable RF Communication Equipment Immunity / IEC 61000-4-3 EN 61000-4-3</p>	<p>380 - 390 MHz, 42 V/m^[1]; 430 - 470 MHz, 42 V/m^[3]; 704 - 787 MHz, 13 V/m^[2]; 800 - 960 MHz, 42 V/m^[1]; 1.7 - 1.99 GHz, 42 V/m^[2]; 2.4 - 2.57 GHz, 42 V/m^[2]; and 5.1 - 5.8 GHz, 13 V/m^[2]</p> <p>[1] 18 Hz Pulse Modulation [2] 217 Hz Pulse Modulation [3] FM at +/- 5 kHz Deviation</p>	<p>Portable RF Communication Equipment (up to 2-Watt max. of transmit power) and its parts (cables, antennas, etc.) operating in the frequencies shown here should not be closer to the HeartMate 3 LVAS with Power Module, and its parts, than 0.2 m (8 inches).</p> <p>Equipment^[a] examples: TETRA 400, GMRS, LTE Bands, GSM and CDMA Phones, UMTS, Bluetooth, WLAN, Wi-Fi†, and RFID systems.</p> <p>Note: 1,000 MHz = 1.0 GHz</p> <p>Note: The recommended minimum separation distance above is a deviation from IEC 60601-1-2 (2014) based on the use-environment of the HeartMate 3 LVAS with Power Module.</p>
<p>Electrical Fast Transient & Burst Immunity / IEC 61000-4-4 EN 61000-4-4</p>	<p>± 2 kV for power supply lines ± 1 kV for input / output lines 100 kHz repetition rate</p>	<p>Mains power quality should be that of a typical commercial or hospital environment where the HeartMate 3 LVAS with Power Module is used.</p>
<p>Surge Immunity / IEC 61000-4-5 EN 61000-4-5</p>	<p>± 0.5, ± 1 kV line to line and ± 0.5, ± 1 kV, and ± 2 kV line to earth</p>	<p>Mains power quality should be that of a typical commercial or hospital environment where the HeartMate 3 LVAS with Power Module is used.</p>

Table C.2 Declaration and Guidance Concerning Electromagnetic Disturbances for the Power Module

<p>Conducted RF Immunity / IEC 61000-4-6 EN 61000-4-6</p>	<p>3 Vrms and 6 Vrms (within ISM bands) 150 kHz – 80 MHz 80% AM at 1 kHz</p>	<p>For many common 2-Watt (maximum) transmitters and some ISM products and their parts (cables, antennas, etc.) operating in the 150 kHz to 80 MHz range, the following minimum separation distance to the HeartMate 3 LVAS with PM is recommended:</p> <p>Outside ISM – 150 kHz - 80 MHz: 1.7 m (5.7 feet)</p> <p>In ISM – 150 kHz - 80 MHz: 2.8 m (9.2 feet)</p> <p>Equipment^[a] examples: CB Radios, Amateur “HAM” radios, and Diathermy medical devices.</p> <p>Note: 1,000 kHz = 1.0 MHz</p> <p>Note: “ISM” = Industrial, Scientific and Medical devices, as per the International Technical Union.</p> <p>[a] – List is not comprehensive.</p>
<p>Power Frequency Magnetic Field Immunity / IEC 61000-4-8 EN 61000-4-8</p>	<p>30 A/m (50 or 60 Hz)</p>	<p>Power Frequency Magnetic Field should be that of a typical commercial or hospital environment where the HeartMate 3 LVAS with PM is used.</p>

Table C.2 Declaration and Guidance Concerning Electromagnetic Disturbances for the Power Module

Voltage Dips, Short Interruptions and Voltage Variations on Power Supply Input Lines Immunity / IEC 61000-4-11 EN 61000-4-11	0 % of U_T ; ½ cycle	Mains power quality should be that of a typical commercial or hospital environment where the HeartMate 3 LVAS with PM is used. Note - U_T : A.C. Mains voltage supply, either 50 or 60 Hz (cycles per sec.)
	0 % of U_T ; 1 cycle	
	and	
	70 % of U_T ; 25 or 30 cycles (0.5 sec.)	
	0 % of U_T ; 250 or 300 cycles (5 sec.)	

Table C.2 Declaration and Guidance Concerning Electromagnetic Disturbances for the Power Module

WARNING !

- The HeartMate 3 Left Ventricular Assist System should not be used adjacent to or stacked with other equipment. If adjacent or stacked use is necessary, the HeartMate 3 Left Ventricular Assist System should be observed to verify normal operation in the configuration in which it will be used.
- To help ensure good electromagnetic performance throughout the usable life of the HeartMate 3 LVAS, be certain to follow the maintenance schedule and procedures as described in Equipment Storage and Care.
- Use of accessories or cables other than those specified or provided by Abbott could result in increased electromagnetic emissions or decreased electromagnetic immunity of this equipment and result in improper operation.
- Portable RF communications equipment (including peripherals such as antenna cables and external antennas) should be used no closer than 20 cm (8 inches) to any part of the HeartMate 3 LVAS (powered by the Power Module), including cables specified by Abbott. Otherwise, degradation of the performance of this equipment could result.
- No modification of this equipment is allowed.

Field strengths from fixed RF transmitters, such as base stations for radios (cellular/cordless) telephones and land mobile radios, amateur radio, AM and FM radio broadcast, and TV broadcast cannot be predicted theoretically with accuracy.

To assess the electromagnetic environment (home, office, etc.) due to fixed RF transmitters, an electromagnetic (EMC) "site survey" (measurement) should be considered. If the measured field strength (in Volts per meter, V/m) in the location(s) in which the HeartMate 3 Left Ventricular Assist System is used exceeds the applicable RF compliance level for the frequency bands above, the HeartMate 3 LVAS should be observed to verify normal operation. If abnormal performance is observed, additional measures may be necessary, such as re-orienting or relocating the HeartMate 3 LVAS.

These guidelines may not apply in all situations.

Note: The EMISSIONS characteristics of this equipment make it suitable for use in industrial areas and hospitals (CISPR 11 class A). If it is used in a residential environment (for which CISPR 11 class B is normally required) this equipment might not offer adequate protection to radio-frequency communication services. The user might need to take mitigation measures, such as relocating or re-orienting the equipment.

Testing and Classification: Mobile Power Unit

Declaration and Guidance for Electromagnetic Disturbances for the Mobile Power Unit

The HeartMate 3™ LVAS (powered by the Mobile Power Unit) is suitable for use in the following environments:

- Hospitals, including ORs and emergency rooms
- Treatment areas near active HF Surgical equipment.
- Homes, workplaces and retail places.
- Public or private passenger watercraft/boats, ferries, etc.

HeartMate 3 LVAS Powered By the Mobile Power Unit		
EM Disturbance type / Standards	IEC 60601-1-2 (2014) Compliance Level	Use Environment Guidance
RF Emissions / CISPR 11 EN 55011	Group 1, Class B 30 – 1,000 MHz	The HeartMate 3 LVAS with Mobile Power Unit is suitable for use in all establishments, including domestic establishments and those directly connected to the public low-voltage power supply (mains) network that supplies domestic (residential) buildings.
Harmonic Emissions / IEC 61000-3-2 EN 61000-3-2	Class A	The HeartMate 3 LVAS with Mobile Power Unit uses RF energy only for its internal purposes and thus has low unintentional RF emissions and is unlikely to cause interference in nearby electronic equipment.
Voltage Fluctuations & Flicker Emissions / IEC 61000-3-3 EN 61000-3-3	Complies fully	
Electrostatic Discharge (ESD) Immunity / IEC 61000-4-2 EN 61000-4-2	±8 kV Contact ±15 kV Air	The relative humidity where the HeartMate 3 LVAS with Mobile Power Unit is used should be at least 5%. Higher relative humidity will reduce the severity of ESD events.

Table C.3 Declaration and Guidance Concerning Electromagnetic Disturbances for Mobile Power Unit

<p>Radiated RF Immunity / IEC 61000-4-3 EN 61000-4-3</p>	<p>10 V/m 80 MHz – 2.7 GHz 80% AM at 1 kHz</p>	<p>For many common 2-Watt (maximum) transmitters in the 80 MHz to 2.7 GHz range, the following minimum separation distances to the HeartMate 3 LVAS with Mobile Power Unit are recommended:</p> <p style="padding-left: 40px;">80 - 800 MHz: 1.7 m (5.7 feet) 800 MHz – 2.7 GHz: 3.3 m (10.8 feet)</p> <p>Note: At 800 MHz, the separation distance for the higher frequency range applies.</p> <p>For many common 10-Watt (maximum) transmitters in the 80 MHz to 2.7 GHz range, the following minimum separation distances to the HeartMate 3 LVAS with Mobile Power Unit are recommended:</p> <p style="padding-left: 40px;">80 - 800 MHz: 3.8 m (12.5 feet) 800 MHz – 2.7 GHz: 7.3 m (24.0 feet)</p> <p>Note: At 800 MHz, the separation distance for the higher frequency range applies.</p> <p>Equipment^[a] examples: Garage door remote controls, emergency services radios, “walkie-talkie” radios, Amateur “HAM” radios, Cellular telephone base stations, and RFID readers.</p> <p>Interference to the HeartMate 3 LVAS may occur near equipment or areas that are marked with the following symbol:</p> <div style="text-align: center;">  </div> <p>Note: 1,000 MHz = 1.0 GHz</p> <p>[a] – List is not comprehensive.</p>
---	--	--

Table C.3 Declaration and Guidance Concerning Electromagnetic Disturbances for Mobile Power Unit

<p>Portable RF Communication Equipment Immunity / IEC 61000-4-3 EN 61000-4-3</p>	<p>380 - 390 MHz, 42 V/m^[1]; 430 - 470 MHz, 42 V/m^[3]; 704 - 787 MHz, 13 V/m^[2]; 800 - 960 MHz, 42 V/m^[1]; 1.7 - 1.99 GHz, 42 V/m^[2]; 2.4 - 2.57 GHz, 42 V/m^[2]; and 5.1 - 5.8 GHz, 13 V/m^[2]</p> <p>[1] 18 Hz Pulse Modulation [2] 217 Hz Pulse Modulation [3] FM at +/- 5 kHz Deviation</p>	<p>Portable RF Communication Equipment (up to 2-Watt of transmit power) and its parts (cables, antennas, etc.) operating in the frequencies shown here should not be closer to the HeartMate 3 LVAS with Mobile Power Unit, and its parts, than 0.2 m (8 inches).</p> <p>Equipment^[a] examples: TETRA 400, GMRS, LTE Bands, GSM and CDMA Phones, UMTS, Bluetooth, WLAN, Wi-Fi, and RFID systems.</p> <p>Note: 1,000 MHz = 1.0 GHz Note: The recommended minimum separation distance above is a deviation from IEC 60601-1-2 (2014) based on the use-environment of the HeartMate 3 LVAS with Mobile Power Unit. [a] – List is not comprehensive.</p>
<p>Electrical Fast Transient & Burst Immunity / IEC 61000-4-4 EN 61000-4-4</p>	<p>± 2 kV for power supply lines ± 1 kV for input / output lines 100 kHz repetition rate</p>	<p>Mains power quality should be that of a typical commercial or hospital environment where the HeartMate 3 LVAS with Mobile Power Unit is used.</p>
<p>Surge Immunity / IEC 61000-4-5 EN 61000-4-5</p>	<p>± 0.5, ± 1 kV line to line</p>	<p>Mains power quality should be that of a typical commercial or hospital environment where the HeartMate 3 LVAS with Mobile Power Unit is used.</p>

Table C.3 Declaration and Guidance Concerning Electromagnetic Disturbances for Mobile Power Unit

<p>Conducted RF Immunity / IEC 61000-4-6 EN 61000-4-6</p>	<p>3 Vrms and 6 Vrms (within ISM and Amateur Radio bands) 150 kHz – 80 MHz 80% AM at 1 kHz</p>	<p>For many common 2-Watt (maximum) transmitters and some ISM products and their parts (cables, antennas, etc.) operating in the 150 kHz to 80 MHz range, the following minimum separation distance to the HeartMate 3 LVAS with Mobile Power Unit is recommended:</p> <p>Outside ISM/Amateur bands – 150 kHz - 80 MHz: 1.7 m (5.7 feet)</p> <p>In ISM/Amateur bands – 150 kHz - 80 MHz: 2.8 m (9.2 feet)</p> <p>Equipment^[a] examples include: CB Radios, Amateur “HAM” radios, Diathermy medical devices,</p> <p>Note: 1,000 kHz = 1.0 MHz</p> <p>Note: “ISM” = Industrial, Scientific and Medical devices, as per the International Technical Union</p> <p>[a] – List is not comprehensive.</p>
<p>Power Frequency Magnetic Field Immunity / IEC 61000-4-8 EN 61000-4-8</p>	<p>30 A/m (50 or 60 Hz)</p>	<p>Power Frequency Magnetic Field should be that of a typical commercial or hospital environment where the HeartMate 3 LVAS with Mobile Power Unit is used.</p>
<p>Voltage Dips, Short Interruptions and Voltage Variations on Power Supply Input Lines Immunity / IEC 61000-4-11 EN 61000-4-11</p>	<p>0 % of U_T; ½ cycle 0 % of U_T; 1 cycle and 70 % of U_T; 25 or 30 cycles (0.5 sec.) 0 % of U_T; 250 or 300 cycles (5 sec.)</p>	<p>Mains power quality should be that of a typical commercial or hospital environment where the HeartMate 3 LVAS with Mobile Power Unit is used.</p> <p>Note – U_T: A.C. Mains voltage supply, either 50 or 60 Hz (cycles per sec.)</p>

Table C.3 Declaration and Guidance Concerning Electromagnetic Disturbances for Mobile Power Unit

WARNING !

- Portable RF communications equipment (including peripherals such as antenna cables and external antennas) should be used no closer than 20 cm (8 inches) to any part of the HeartMate 3 LVAS (powered by the Mobile Power Unit), including cables specified by Abbott. Otherwise, degradation of the performance of this equipment could result.
- To help ensure good electromagnetic performance throughout the usable life of the HeartMate 3 LVAS, be certain to follow the maintenance schedule and procedures as described in Equipment Storage and Care.
- Avoid use of the HeartMate 3 LVAS (and its cables and parts) within 5 cm (2 inches) of a microwave oven or its cord. Keep all HeartMate 3 LVAS components and their cables away from other electronic devices and their cables/cords.
- The HeartMate 3 Left Ventricular Assist System should not be used adjacent to or stacked with other equipment. If adjacent or stacked use is necessary, the HeartMate 3 Left Ventricular Assist System should be observed to verify normal operation in the configuration in which it will be used.
- Use of accessories or cables other than those specified or provided by Abbott could result in increased electromagnetic emissions or decreased electromagnetic immunity of this equipment and result in improper operation.
- No modification of this equipment is allowed.

Field strengths from fixed RF transmitters, such as base stations for radios (cellular/cordless) telephones and land mobile radios, amateur radio, AM and FM radio broadcast, and TV broadcast cannot be predicted theoretically with accuracy.

To assess the electromagnetic environment (home, office, etc.) due to fixed RF transmitters, an electromagnetic (EMC) "site survey" (measurement) should be considered. If the measured field strength (in Volts per meter, V/m) in the location(s) in which the HeartMate 3 Left Ventricular Assist System is used exceeds the applicable RF compliance level for the frequency bands above, the HeartMate 3 LVAS should be observed to verify normal operation. If abnormal performance is observed, additional measures may be necessary, such as re-orienting or relocating the HeartMate 3 LVAS.

These guidelines may not apply in all situations.

Testing and Classification: Battery Charger

The Battery Charger complies with the following safety standards:

- EN 60950-1: 2006 + A11: 2009 + A1: 2010 + A12: 2011
- IEC 60950-1: 2005, 2nd Edition + Am1:2009
- UL 60950-1, 2nd Edition, 2011
- CSA C22.2 No. 60950-1-07, 2nd Edition, 2011
- IEC 60601-1: 1988, 2nd Edition, A1:1991, A2:1995
- UL 60601-1, 1st Edition, 2003-04-26 (included National Differences for USA)
- EN 60601-1:1990 + A1:1993 + A2:1995 + A13:1996
- CAN/CSA C22.2 No.601.1-M90 (R1997), CAN/CSA C22.2 No.601.1S1-94, and CAN/CSA C22.2 No.601.1B-98 (National Difference for Canada)

This equipment was tested according to the recommendations of IEC TR 60601-4-2: Medical Electrical Equipment - Part 4-2: Guidance and interpretation - Electromagnetic immunity: performance of medical electrical equipment and medical electrical systems. These limits are designed to provide reasonable protection against harmful interference in a typical medical installation. This equipment is an unintentional radiator of radio frequency energy and, if not installed and used in accordance with the instructions, may cause harmful interference to other devices in the vicinity. However, there is no guarantee that interference will not occur in a particular installation. If this equipment does cause harmful interference to other devices, which can be determined by turning the equipment off and on, the user is encouraged to try to correct the interference by one or more of the following measures:

- Reorient or relocate the equipment.
- Increase the separation between the equipment.
- Connect the equipment into an outlet on a circuit different from that to which the other devices are connected.
- Consult Abbott for assistance.

Declaration Concerning General Safety Standards for Battery Charger

Type	Degree of Protection
Mode of Operation	Continuous
Type of protection against mains shock	Class I (grounded)
Degree of protection against harmful ingress of water	IPX0

Table C.4 Declaration Concerning General Safety Standards for Battery Charger

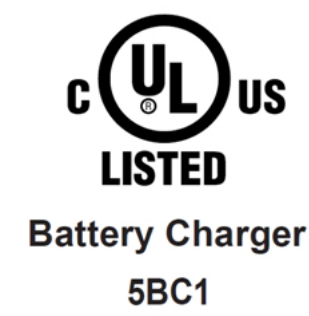

Declaration and Guidance for Electromagnetic Disturbances for Battery Charger

The HeartMate Battery Charger is suitable for use in the following environments:

- Hospitals, including ORs and emergency rooms
- Homes, workplaces and retail places
- Public or private passenger watercraft/boats, ferries, etc.

HEARTMATE BATTERY CHARGER		
EM Disturbance type / Standards	IEC TR 60601-4-2 Compliance Level	Use Environment Guidance
RF Emissions / CISPR 11 EN 55011	Group 1, Class B 30 – 1,000 MHz	The HeartMate Battery Charger is suitable for use in all establishments, including domestic establishments and those directly connected to the public low-voltage power supply (mains) network that supplies domestic (residential) buildings.
Harmonic Emissions / IEC 61000-3-2 EN 61000-3-2	Class A	
Voltage Fluctuations & Flicker Emissions / IEC 61000-3-3 EN 61000-3-3	Complies fully	The HeartMate Battery Charger uses RF energy only for its internal purposes and thus has low unintentional RF emissions and is unlikely to cause interference in nearby electronic equipment.
Electrostatic Discharge (ESD) Immunity / IEC 61000-4-2 EN 61000-4-2	±6 kV Contact ±8 kV Air	The relative humidity should be at least 20%. Higher relative humidity will reduce the severity of ESD events.

Table C.5 Declaration and Guidance Concerning Electromagnetic Disturbances for Battery Charger

<p>Radiated RF Immunity / IEC 61000-4-3 EN 61000-4-3</p>	<p>3 V/m 80 MHz – 2.7 GHz 80% AM at 1 kHz</p>	<p>For many common 2-Watt (maximum) transmitters in the 80 MHz to 2.7 GHz range, the following minimum separation distances to the HeartMate Battery Charger are recommended:</p> <p style="text-align: center;">80 - 800 MHz: 1.7 m (5.7 feet) 800 MHz – 2.7 GHz: 3.3 m (10.8 feet)</p> <p>Note: At 800 MHz, the separation distance for the higher frequency range applies.</p> <p>For many common 10-Watt (maximum) transmitters in the 80 MHz to 2.7 GHz range, the following minimum separation distances to the HeartMate Battery Charger are recommended:</p> <p style="text-align: center;">80 - 800 MHz: 3.8 m (12.5 feet) 800 MHz – 2.7 GHz: 7.3 m (24.0 feet)</p> <p>Note: At 800 MHz, the separation distance for the higher frequency range applies.</p> <p>Equipment^[a] examples: Garage door remote controls, emergency services radios, “walkie-talkie” radios, Amateur “HAM” radios, Cellular telephone base stations, and RFID readers.</p> <p>Interference to the HeartMate Battery Charger may occur near equipment or areas that are marked with the following symbol:</p> <div style="text-align: center;">  </div> <p>Note: 1,000 MHz = 1.0 GHz</p> <p>[a] – List is not comprehensive.</p>
---	---	---

Table C.5 Declaration and Guidance Concerning Electromagnetic Disturbances for Battery Charger

<p>Portable RF Communication Equipment Immunity / IEC 61000-4-3 EN 61000-4-3</p>	<p>380 - 390 MHz, 27 V/m^[1]; 430 - 470 MHz, 28 V/m^[3]; 704 - 787 MHz, 9 V/m^[2]; 800 - 960 MHz, 28 V/m^[1]; 1.7 - 1.99 GHz, 28 V/m^[2]; 2.4 - 2.57 GHz, 28 V/m^[2]; and 5.1 - 5.8 GHz, 9 V/m^[2]</p> <p>[1] 18 Hz Pulse Modulation [2] 217 Hz Pulse Modulation [3] FM at +/- 5 kHz Deviation</p>	<p>Portable RF Communication Equipment (up to 2-Watt max. of transmit power) and its parts (cables, antennas, etc.) operating in the frequencies shown here should not be closer to the HeartMate Battery Charger, and its parts, than 0.3 m (12 inches).</p> <p>Equipment^[a] examples: TETRA 400, GMRS, LTE Bands, GSM and CDMA Phones, UMTS, Bluetooth, WLAN, Wi-Fi, and RFID systems.</p> <p>Note: 1,000 MHz = 1.0 GHz [a] – List is not comprehensive.</p>
<p>Electrical Fast Transient & Burst Immunity / IEC 61000-4-4 EN 61000-4-4</p>	<p>± 2 kV for power supply lines 100 kHz repetition rate</p>	<p>Mains power quality should be that of a typical commercial or hospital environment where the HeartMate Battery Charger is used.</p>
<p>Surge Immunity / IEC 61000-4-5 EN 61000-4-5</p>	<p>± 0.5, ± 1 kV line to line and ± 0.5, ± 1 kV, and ± 2 kV line to earth</p>	<p>Mains power quality should be that of a typical commercial or hospital environment where the HeartMate Battery Charger is used.</p>

Table C.5 Declaration and Guidance Concerning Electromagnetic Disturbances for Battery Charger

<p>Conducted RF Immunity / IEC 61000-4-6 EN 61000-4-6</p>	<p>3 Vrms and 6 Vrms (Within ISM and Amateur Radio bands) 150 kHz – 80 MHz 80% AM at 1 kHz</p>	<p>For many common 2-Watt (maximum) transmitters and some ISM products and their parts (cables, antennas, etc.) operating in the 150 kHz to 80 MHz range, the following minimum separation distance to the HeartMate Battery Charger is recommended:</p> <p>150 kHz - 80 MHz: 1.7 m (5.7 feet)</p> <p>Equipment^[a] examples include: CB Radios, Amateur "HAM" radios, and Diathermy medical devices.</p> <p>Note: 1,000 kHz = 1.0 MHz</p> <p>Note: "ISM" = Industrial, Scientific and Medical devices, as per the International Technical Union</p> <p>[a] – List is not comprehensive.</p>
<p>Power Frequency Magnetic Field Immunity / IEC 61000-4-8 EN 61000-4-8</p>	<p>3 A/m (50 or 60 Hz)</p>	<p>Power Frequency Magnetic Field should be that of a typical commercial or hospital environment where the HeartMate Battery Charger is used.</p>
<p>Voltage Dips, Short Interruptions and Voltage Variations on Power Supply Input Lines Immunity / IEC 61000-4-11 EN 61000-4-11</p>	<p>0 % of U_T; ½ cycle 0 % of U_T; 1 cycle and 70 % of U_T; 25 or 30 cycles (0.5 sec.) 0 % of U_T; 250 or 300 cycles (5 sec.)</p>	<p>Mains power quality should be that of a typical commercial or hospital environment where the HeartMate Battery Charger is used.</p> <p>U_T: A.C. Mains voltage supply, either 50 or 60 Hz (cycles per sec.)</p>

Table C.5 Declaration and Guidance Concerning Electromagnetic Disturbances for Battery Charger

WARNING !

- Portable RF communications equipment (including peripherals such as antenna cables and external antennas) should be used no closer than 30 cm (12 inches) to any part of the HeartMate 3 Battery Charger, including cables specified by Abbott. Otherwise, degradation of the performance of this equipment could result.
- Use of accessories or cables other than those specified or provided by Abbott could result in increased electromagnetic emissions or decreased electromagnetic immunity of this equipment and result in improper operation.
- Do not use the Battery Charger next to other equipment.
- Do not stack the Battery Charger on top of other equipment.
- No modification of this equipment is allowed.

Field strengths from fixed RF transmitters, such as base stations for radios (cellular/cordless) telephones and land mobile radios, amateur radio, AM and FM radio broadcast, and TV broadcast cannot be predicted theoretically with accuracy.

To assess the electromagnetic environment (home, office, etc.) due to fixed RF transmitters, an electromagnetic (EMC) "site survey" (measurement) should be considered. If the measured field strength (in Volts per meter, V/m) in the location(s) in which the HeartMate 3 Left Ventricular Assist System is used exceeds the applicable RF compliance level for the frequency bands above, the HeartMate 3 LVAS should be observed to verify normal operation. If abnormal performance is observed, additional measures may be necessary, such as re-orienting or relocating the HeartMate 3 LVAS.

These guidelines may not apply in all situations.

Testing and Classification: HeartMate 14 Volt Lithium-Ion Batteries

HeartMate 14 Volt Lithium-Ion batteries comply with the following safety standards:

- IEC/EN 62133
- UL 2054
- UN 38.3 T1-8

Declaration Concerning General Safety Standards for HeartMate 14 Volt Lithium-Ion Batteries

Type	Degree of Protection
Degree of protection against electric shock	No Applied Part
Degree of safety of application in the presence of a flammable anesthetic mixture with air or with oxygen or nitrous oxide	Equipment not suitable for use in the presence of a flammable anesthetic mixture with air or with oxygen or nitrous oxide
Degree of protection against harmful ingress	IP24 only when connected to the System Controller through Clip

Table C.6 Declaration Concerning General Safety Standards for HeartMate 14 Volt Lithium-Ion Batteries



Declaration and Guidance for Electromagnetic Disturbances for HeartMate 3 Powered by 14 Volt Lithium-Ion Batteries

The HeartMate 3 Left Ventricular Assist System with 14 Volt Lithium-Ion batteries is intended for use in the electromagnetic environment specified below. The customer or the user of the HeartMate 3 Left Ventricular Assist System should assure that it is used in such an environment.

The HeartMate 3 LVAS (powered by 14V Li-Ion batteries) is suitable for use in the following environments:

- Hospitals, including ORs and emergency rooms
- Treatment areas near active HF Surgical equipment
- Homes, workplaces and retail places
- Passenger automobiles, ambulances, buses, etc.
- Commercial aircraft, including helicopters and air ambulances
- Public or private passenger watercraft/boats, ferries, etc.

HeartMate 3 LVAS Powered By the 14V Li-Ion Batteries		
EM (Electromagnetic) Disturbance type / Standards	IEC 60601-1-2 (2014) Compliance Level	Use Environment Guidance
RF Emissions / CISPR 11 EN 55011	Group 1, Class B (radiated only) 30 – 1,000 MHz	The HeartMate 3 LVAS with 14V Li-Ion Batteries is suitable for use in all establishments, including domestic establishments and those directly connected to the public low-voltage power supply (mains) network that supplies domestic (residential) buildings. The HeartMate 3 LVAS with 14V Li-Ion Batteries uses RF energy only for its internal purposes and thus has low unintentional RF emissions and is unlikely to cause interference in nearby electronic equipment.
Electrostatic Discharge (ESD) Immunity / IEC 61000-4-2 EN 61000-4-2	±8 kV Contact ±15 kV Air	The relative humidity where the HeartMate 3 LVAS with 14V Li-Ion Batteries is used should be at least 5%. Higher relative humidity will reduce the severity of ESD events.

Table C.7 Declaration and Guidance Concerning Electromagnetic Disturbances for 14 V Li-Ion Batteries

<p>Radiated RF Immunity / IEC 61000-4-3 EN 61000-4-3</p>	<p>20 V/m 80 MHz – 2.7 GHz 80% AM at 1 kHz</p>	<p>For many common 2-Watt (maximum) transmitters in the 80 MHz to 2.7 GHz range, the following minimum separation distances to the HeartMate 3 LVAS with 14V Li-Ion Batteries are recommended:</p> <p style="text-align: center;">80 - 800 MHz: 0.85 m (2.8 feet) 800 MHz – 2.7 GHz: 1.7 m (5.6 feet)</p> <p>Note: At 800 MHz, the separation distance for the higher frequency range applies.</p> <p>For many common 10-Watt (maximum) transmitters in the 80 MHz to 2.7 GHz range, the following minimum separation distances to the HeartMate 3 LVAS with 14V Li-Ion Batteries are recommended:</p> <p style="text-align: center;">80 - 800 MHz: 1.9 m (6.2 feet) 800 MHz – 2.7 GHz: 3.8 m (12 feet)</p> <p>Note: At 800 MHz, the separation distance for the higher frequency range applies.</p> <p>Equipment^[a] examples: Garage door remote controls, emergency services radios, “walkie-talkie” radios, Amateur “HAM” radios, Cellular telephone base stations, and RFID readers.</p> <p>Interference to the HeartMate 3 LVAS may occur near equipment or areas that are marked with the following symbol:</p> <div style="text-align: center;">  </div> <p>Note: 1,000 MHz = 1.0 GHz</p> <p>[a] – List is not comprehensive.</p>
---	--	---

Table C.7 Declaration and Guidance Concerning Electromagnetic Disturbances for 14 V Li-Ion Batteries

<p>Portable RF Communication Equipment Immunity / IEC 61000-4-3 EN 61000-4-3</p>	<p>380 - 390 MHz, 42 V/m^[1]; 430 - 470 MHz, 42 V/m^[3]; 704 - 787 MHz, 13 V/m^[2]; 800 - 960 MHz, 42 V/m^[1]; 1.7 - 1.99 GHz, 42 V/m^[2]; 2.4 - 2.57 GHz, 42 V/m^[2]; and 5.1 - 5.8 GHz, 13 V/m^[2]</p> <p>[1] 18 Hz Pulse Modulation [2] 217 Hz Pulse Modulation [3] FM at +/- 5 kHz Deviation</p>	<p>Portable RF Communication Equipment (up to 2-Watt max. of transmit power) and its parts (cables, antennas, etc.) operating in the frequencies shown here should not be closer to the HeartMate 3 LVAS with 14V Li-Ion Batteries, and its parts, than 0.2 m (8 inches).</p> <p>Equipment^[a] examples: TETRA 400, GMRS, LTE Bands, GSM and CDMA Phones, UMTS, Bluetooth, WLAN, Wi-Fi, and RFID systems.</p> <p>Note: 1,000 MHz = 1.0 GHz</p> <p>Note: The recommended minimum separation distance above is a deviation from IEC 60601-1-2 (2014) based on the use-environment of the HeartMate3 LVAS with 14V Batteries.</p> <p>[a] – List is not comprehensive.</p>
---	--	--

Table C.7 Declaration and Guidance Concerning Electromagnetic Disturbances for 14 V Li-Ion Batteries

<p>Conducted RF Immunity / IEC 61000-4-6 EN 61000-4-6</p>	<p>3 Vrms and 6 Vrms (within ISM and Amateur bands) 150 kHz – 80 MHz 80% AM at 1 kHz</p>	<p>For many common 2-Watt (maximum) transmitters and some ISM products and their parts (cables, antennas, etc.) operating in the 150 kHz to 80 MHz range, the following minimum separation distance to the HeartMate 3 LVAS with 14V Li-Ion Batteries is recommended:</p> <p>Outside ISM bands – 150 kHz - 80 MHz: 1.7 m (5.7 feet)</p> <p>In ISM/Amateur bands – 150 kHz - 80 MHz: 2.8 m (9.2 feet)</p> <p>Equipment^[a] examples include: CB Radios, Amateur “HAM” radios, Diathermy medical devices,</p> <p>Note: 1,000 kHz = 1.0 MHz</p> <p>Note: “ISM” = Industrial, Scientific and Medical devices, as per the International Technical Union</p> <p>[a] – List is not comprehensive.</p>
<p>Power Frequency Magnetic Field Immunity / IEC 61000-4-8 EN 61000-4-8</p>	<p>30 A/m (50 or 60 Hz)</p>	<p>Power Frequency Magnetic Field should be that of a typical commercial or hospital environment where the HeartMate 3 LVAS with 14V Li-Ion Batteries is used.</p>

Table C.7 Declaration and Guidance Concerning Electromagnetic Disturbances for 14 V Li-Ion Batteries

WARNING !

- Portable RF communications equipment (including peripherals such as antenna cables and external antennas) should be used no closer than 20 cm (8 inches) to any part of the HeartMate 3 LVAS (powered by the 14V Li-Ion Batteries), including cables specified by Abbott. Otherwise, degradation of the performance of this equipment could result.
- Use of accessories or cables other than those specified or provided by Abbott could result in increased electromagnetic emissions or decreased electromagnetic immunity of this equipment and result in improper operation.
- Avoid use of HeartMate 3 LVAS (and its cables and parts) within 5 cm (2 inches) of a microwave oven or its cord.
- To help ensure good electromagnetic performance throughout the usable life of the HeartMate 3 LVAS, be certain to follow the maintenance schedule and procedures as described in Equipment Storage and Care.

Field strengths from fixed RF transmitters, such as base stations for radios (cellular/cordless) telephones and land mobile radios, amateur radio, AM and FM radio broadcast, and TV broadcast cannot be predicted theoretically with accuracy.

The HeartMate 3 LVAS with 14V Li-Ion Batteries meets the electromagnetic radiated emissions requirements of RTCA/DO-160G (also EUROCAE ED-14G), Sec. 21, for Category "M" location devices.

The HeartMate 3 LVAS with 14V Li-Ion Batteries meets the radiated and conducted (due to RF) electromagnetic immunity requirements of RTCA/DO-160G (also EUROCAE ED-14G), Sec. 20, for Category "R" location devices.

To assess the electromagnetic environment (home, office, etc.) due to fixed RF transmitters, an electromagnetic (EMC) "site survey" (measurement) should be considered. If the measured field strength (in Volts per meter, V/m) in the location(s) in which the HeartMate 3 Left Ventricular Assist System is used exceeds the applicable RF compliance level for the frequency bands above, the HeartMate 3 LVAS should be observed to verify normal operation. If abnormal performance is observed, additional measures may be necessary, such as re-orienting or relocating the HeartMate 3 LVAS.

These guidelines may not apply in all situations.

This equipment has been tested and found to comply with the limits for medical devices to IEC 60601-1-2:2014. These limits are designed to provide reasonable protection against harmful interference in a typical medical installation. This equipment generates, uses and can radiate radio frequency energy and, if not installed and used in accordance with the instructions, may cause harmful interference to other devices in the vicinity. However, there is no guarantee that interference will not occur in a particular installation. If this equipment does cause harmful interference to other devices, which can be determined by turning the equipment off and on, the user is encouraged to try to correct the interference by one or more of the following measures:

- Reorient or relocate the equipment.
- Increase the separation between the equipment.
- Connect the equipment into an outlet on a circuit different from that to which the other device(s) are connected.
- Consult Abbott for assistance.

CAUTION !

Use of equipment and supplies other than those specified in the manuals or sold by Abbott for replacement parts may affect the electromagnetic compatibility of the Left Ventricular Assist System with other devices, resulting in potential interference between the HeartMate 3 Left Ventricular Assist System and other devices.

HEARTMATE 3™ PRODUCT LIST

This section lists the HeartMate 3™ products.

HeartMate 3™ Left Ventricular Assist System Products

All Abbott products are supported with a comprehensive one-year warranty, including parts and labor. For a complete list of all Abbott products, including country-specific catalog numbers, contact Abbott. Refer to the *Back Cover* of this manual for Abbott contact information.

CAUTION !

For the safe repair and replacement of components, contact Abbott for customer service assistance. Refer to the *Back Cover* of this manual for contact information. Failure to heed this caution may cause the pump to stop.

Surgical Procedure

ITEM	CATALOG NUMBER
<p>HeartMate 3™ Left Ventricular Assist System Implant Kit</p> <p>Supplied Sterile</p> <ul style="list-style-type: none"> • 1 Left Ventricular Assist Device (LVAD) Assembly (with Tunneling Adapter) • 1 14mm Sealed Outflow Graft with Bend Relief • 1 Apical Cuff • 1 Coring Knife (20mm) • 1 Skin Coring Punch (6mm) • 1 Set HeartMate 3 Thread Protectors • 1 Modular Cable (with Modular Cable Cap) • 1 System Controller (with 11 Volt Lithium-Ion Backup Battery) <p>Also Included:</p> <ul style="list-style-type: none"> • 1 <i>HeartMate 3 Left Ventricular Assist System Instructions for Use</i> • 1 <i>HeartMate 3 Left Ventricular Assist System Patient Handbook</i> • 1 Wearable Accessories Kit (includes 1 System Controller Neck Strap, 1 Belt Attachment, and 1 Protection Bag) 	106524US
<p>HeartMate 3 Left Ventricular Assist System Mini Kit</p> <p>Supplied Sterile</p> <ul style="list-style-type: none"> • 1 Left Ventricular Assist Device (LVAD) Assembly (with Tunneling Adapter) • 1 Apical Cuff • 1 Coring Knife (20mm) • 1 Skin Coring Punch (6mm) 	10001696

ITEM	CATALOG NUMBER
<ul style="list-style-type: none"> • 1 Set HeartMate 3 Thread Protectors • 1 Modular Cable (with Modular Cable Cap) • 1 System Controller (with 11 Volt Lithium-Ion Backup Battery) <p>Also Included:</p> <ul style="list-style-type: none"> • 1 <i>HeartMate 3 Left Ventricular Assist System Instructions for Use</i> • 1 <i>HeartMate 3 Left Ventricular Assist System Patient Handbook</i> 	
<p>HeartMate 3 Sealed Standalone Outflow Graft with Bend Relief Supplied sterile.</p>	105581US
<p>Coring Knife Supplied sterile.</p>	1050
<p>HeartMate 3 Modular Cable Supplied sterile.</p>	106525US
<p>HeartMate 3 Tunneling Lance and Handle Supplied non-sterile.</p>	10010372GBL
<p>HeartMate 3 Left Ventricular Assist System Surgical Hand Tools Supplied non-sterile.</p> <ul style="list-style-type: none"> • Outflow Pliers • Unlock Tool 	10002222US
<p>HeartMate™ Explant Kit Supplied non-sterile. No charge with Returned Materials Authorization for explanted pump.</p>	28717
<p>Modular Cable Cap Supplied sterile. Standalone package of 3.</p>	106526US
<p>HeartMate 3 Outflow Graft Clip Supplied sterile.</p>	10012390GBL
<p>HeartMate 3 Skin Coring Punch Supplied sterile.</p>	106528US
<p>HeartMate 3 Apical Cuff Supplied sterile.</p>	106522US
<p>HeartMate 3 Tunneling Adapter Supplied sterile. Standalone package of 3.</p>	106534US
<p>HeartMate 3 Thread Protectors Supplied sterile. Standalone package of 5.</p>	106532US

System Operations

ITEM	CATALOG NUMBER
<p>HeartMate 3™ System Controller Supplied sterile. A small computer that controls and monitors system operation. Uses lights, sounds, and on-screen messages to communicate with users about operating status and alarm conditions. Includes 11 Volt Lithium-Ion System Controller Backup Battery. Includes Patient Handbook.</p>	106531US
<p>11 Volt Lithium-Ion System Controller Backup Battery When fully-charged and properly installed in System Controller, provides at least 15 minutes of emergency power to the pump if the in-use power disconnects or fails.</p>	106128

Powering the System

ITEM	CATALOG NUMBER
<p>Power Module Provides power to the HeartMate 3™ system when connected via a power cord to a functioning AC electrical outlet. Connects to the HeartMate Touch Communication System (Catalog Number HMT1100) for purposes of transferring data from the System Controller for display on the HeartMate Touch Communication System screen. Connects to System Controller through the Power Module Patient Cable (Catalog Number 103426).</p>	1340
<p>Mobile Power Unit Provides power to the HeartMate 3 system when connected via a power cord to a functioning AC electrical outlet. For home or clinical use.</p>	107754
<p>Mobile Power Unit AC Power Cord AC power cord to connect the Mobile Power Unit to an AC electrical outlet.</p>	107760
<p>Battery Charger Used to charge, calibrate, and test the HeartMate™ 14 Volt Lithium-Ion batteries used to power the HeartMate 3 system during battery-powered operation.</p>	1440
<p>HeartMate 14 Volt Lithium-Ion Battery Set Set of 4 rechargeable 14 Volt Lithium-Ion batteries used for mobile operation. Batteries are recharged using the Battery Charger (Catalog Number 1440).</p>	2465
<p>14 Volt Battery Clip Set Set of 2 battery clips that are compatible with 14 Volt Lithium-Ion batteries (Catalog Number 2465) and used for mobile operation.</p>	2865

ITEM	CATALOG NUMBER
<p>Power Module Backup Battery A backup power source inside the Power Module that gives up to 30 minutes of support if power to the Power Module fails or is disconnected.</p>	109200
<p>Power Module Patient Cable Connects System Controller to Power Module.</p>	103426
<p>Power Module/Battery Charger AC Power Cord AC power cord that is compatible with both devices.</p>	103860

HeartMate Touch™ Communication System

ITEM	CATALOG NUMBER
<p>HeartMate Touch Communication System The HeartMate Touch Communication System includes the following components: Tablet for use with the HeartMate Touch App, HeartMate Touch Wireless Adapter, Power Adapter and USB cable and the Flash Drive.</p>	HMT1100
<p>Flash Drive The Flash Drive has a Lightning connector and USB connector. The Flash Drive is used for exporting, transferring, and storing data generated from the HeartMate Touch App.</p>	HMT2900
<p>HeartMate Touch Wireless Adapter - Bluetooth® Low Energy The HeartMate Touch Wireless Adapter is required for using the HeartMate Touch Communication System with the Power Module and System Controller.</p>	HMT2100
<p>USB Cable for HeartMate Touch Communication System The USB Cable is plugged into the Tablet and Power Adapter and supplies AC power from an AC electrical power outlet to the Tablet.</p>	HMT2166
<p>Power Adapter for HeartMate Touch Communication System The Power Adapter is plugged into an AC electrical power outlet and the USB Cable for the HeartMate Touch Communication System plugs into the Power Adapter.</p>	HMT2133

Wear and Carry Accessories













ITEM	CATALOG NUMBER
Wearable Accessories Kit Includes: <ul style="list-style-type: none"> • 1 System Controller Neck Strap • 1 Belt Attachment • 1 Protection Bag 	106129
Consolidated Bag, Left Configured for wear on the left side of the body (black only).	106449
Consolidated Bag, Right Configured for wear on the right side of the body (black only).	104233
Holster Vest, Small For wearing 14 Volt Lithium-Ion batteries.	104229
Holster Vest, Medium For wearing 14 Volt Lithium-Ion batteries.	104230
Holster Vest, Large For wearing 14 Volt Lithium-Ion batteries.	104231
Battery Holster Set of 2.	104234
Shower Bag Set of 2.	104232
Travel Bag	1260
HeartMate ICU Cover, 1-Pack	10003491
HeartMate ICU Cover, 6-Pack	10002151

SYMBOLS











This section describes the symbols that are used on the HeartMate 3™ Left Ventricular Assist System components, accessories, or packaging.

Description of Labeling Symbols















General Symbols

SYMBOL	DESCRIPTION
	Manufacturer
	Date of manufacture
	Catalog Number
	Serial Number
	Batch Code
	Caution: US federal law restricts this device to sale by or on the order of a physician
	Temperature Limitation
	Sterilized by Ethylene Oxide
	Non-sterile
	Do not re-sterilize
	Follow Instructions for Use
	Japan - Giteki Type Certification Mark

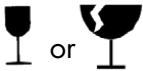
Appendix E Symbols

SYMBOL	DESCRIPTION
	Australia / New Zealand - Regulatory Compliance Mark (RCM)
	Internal Part Number
	Do not use if package is damaged
	MR Unsafe - Do not subject to magnetic resonance imaging
	Do not reuse
1	Quantity of contents
	Peel Tab
	« Caution » «Attention, See instructions for use »
IPxx	Degrees of protection provided by enclosures
	Operating Temperature
	UL Recognized Component
	Contains Lithium-Ion, recycle in accordance with local, state, and federal regulations.
	Separate collection for batteries and accumulators

Appendix E Symbols

SYMBOL	DESCRIPTION
	Separate collection for waste electrical and electronic equipment
	Expiration Date: Use by (Expiration Date)
	Keep dry
	Contents Quantity
	Tablet for use with the HeartMate Touch App
	Accessories
	UDI Identification
	Non-ionizing radiation
	Fragile
	Non-pyrogenic
	This end up
	Alternating current
	UL product safety mark
	Consult Instructions For Use

Appendix E Symbols

SYMBOL	DESCRIPTION
 medical.abbott/manuals	Follow Instructions for Use on this website

Specific 14 Volt Lithium-Ion Battery Symbols

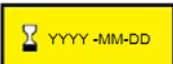
Symbol	Description
On-product symbols	See <i>Checking Battery Charge Status Using the On-Battery Power Gauge</i> on page 3-56.
	Charge By. HeartMate™ 14 Volt Lithium-Ion batteries must be charged at least once by the end of the month marked on the label affixed to battery packaging (box and protective bag).
	Expiration Date: Use by (Expiration Date)







Specific 11 Volt Lithium-Ion Backup Battery Symbols

Symbol	Description
	Backup Battery Expiration Date: Use by (Expiration Date)

Specific System Controller Symbols

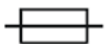
Symbol	Description
On-product symbols	See <i>System Controller User Interface Overview</i> on page 2-14
	Indicates the HeartMate 3™ LVAS is operating in Pulse Mode (as shown on the System Controller LCD display).

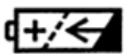
Specific Power Module Symbols

Symbol	Description
On-product symbols	<ul style="list-style-type: none"> • See <i>Handling Power Module Alarms</i> on page 7-37 • See <i>Checking the Charge Status of the Power Module Backup Battery</i> on page 3-24
	Monitor
	Type “CF” Symbol: Patient cable connection
	Power ON/OFF: When the Power Module is plugged into a wall socket, this symbol illuminates green. When the Power Module is operating on internal battery power with less than 15 minutes of power left, this symbol illuminates yellow.
	Fuse Rating: T 2A, 250 V
	Direct Current
	Rechargeable Battery: When the Power Module is recharging the internal battery, this symbol illuminates yellow. When the internal battery is fully charged, this battery symbol illuminates green.
	Battery Check: When the Power Module is operating on internal battery power with less than 15 minutes of power left, this symbol illuminates yellow as an Advisory alarm. When only 5 minutes of internal battery power remain, this symbol illuminates red as a Hazard alarm.

Specific Mobile Power Unit Symbols

Symbol	Description
On-product symbols	See <i>Mobile Power Unit User Interface Components</i> on page 3-38

SAFETY CHECKLISTS

This section provides checklists to assist you in performing routine maintenance of the HeartMate 3™ Left Ventricular Assist Device.

Daily Safety Checklist- - - - -	-F-2
Weekly Safety Checklist - - - - -	-F-4
Monthly Safety Checklist - - - - -	-F-5
Six Month Safety Checklist - - - - -	-F-8
Yearly Safety Checklist - - - - -	-F-10
As-Needed Safety Checklist- - - - -	-F-11
Clinic Visit Safety Checklist - - - - -	-F-12

Daily Safety Checklist

Daytime Checklist:

- Perform System Controller self test.
- When using a new power source, inspect System Controller power cable connectors for dirt, grease, or damage.
- When changing power sources, inspect connectors on battery clips for dirt, grease, or damage.
- When switching from the battery power to the Power Module or the Mobile Power Unit, inspect the connector pins and sockets for dirt, grease, or damage.
- Ensure that the Modular inline Connector is secure and the connector locking nut is in the locked position. Ensure no yellow indicator is seen under the inline locking nut.
- Perform a Power Module self test.
- Maintain the Power Module connection to the AC power source. If not properly monitored, the internal battery drains, causing potential damage.
- Manage the Driveline exit site in accordance with the instructions provided by the clinician.
- Inspect the Driveline exit site for signs of infection, including redness, tenderness, swelling, discharge, or a foul odor. Use sterile technique to touch or handle the exit site.

Sleep Checklist:

- Always connect to the Power Module or the Mobile Power Unit for sleeping or when there is a chance of sleep, as a sleeping patient may not hear system alarms (see *When to Connect to the Power Module* on page 3-17 or *When to Connect to the Mobile Power Unit* on page 3-46).
- Check all electrical connections between the System Controller and power cables, the power cables and the Power Module patient cable or the Mobile Power Unit patient cable, and the Power Module or the Mobile Power Unit and AC electrical outlet.
- Confirm bedside items are in place:
 - Working flashlight with charged batteries.
 - Backup System Controller.
 - Two charged HeartMate™ 14 Volt Lithium-Ion batteries and two 14 Volt battery clips.
- Inspect the Driveline Cable for signs of damage, such as cracking, fraying, wear, exposed wires, sharp bends or kinks.
- Ensure that the Modular inline Connector is secure and the connector locking nut is in the locked position. Ensure no yellow indicator is seen under the inline locking nut.
- Inspect all cables for signs of damage.

Weekly Safety Checklist

- Review Replacing the Running System Controller with a Backup Controller instructions in Section 2.
- Clean the metal battery terminals and contacts inside the battery clips.
- Inspect the Power Module or Mobile Power Unit power cord, used to connect the Power Module to the AC electrical outlet, for damage or wear. Ensure that the cord is not kinked, split, cut, cracked, or frayed. Do not use the cord if it shows signs of damage. Obtain a replacement from Abbott, if needed.
- Manage the Driveline exit site in accordance with the instructions provided by the clinician.
- Inspect the Power Module patient cable or Mobile Power Unit patient cable, used to connect the System Controller to the Power Module or the Mobile Power Unit, for damage or wear. Ensure that the cable is not kinked, split, cut, cracked, or frayed. Do not use the Power Module patient cable or the Mobile Power Unit patient cable if it shows signs of damage. Obtain a replacement from Abbott, if needed.
- Inspect HeartMate™ 14 Volt Lithium-Ion batteries for damage. Check the battery contacts for denting or damage. Replace damaged batteries. Do not use batteries that appear damaged.
- Inspect the Battery Charger for signs of physical damage, such as dents, chips, or cracks. Do not use the Battery Charger if it shows signs of damage. Obtain a replacement from Abbott, if needed.
- Inspect the power cord that is used to connect the Battery Charger to an AC outlet. Ensure that the cord is not kinked, split, cut, cracked, or frayed. Do not use the cord if it shows signs of damage. Obtain a replacement from Abbott, if needed.
- Inspect wear and carry accessories (including the Consolidated Bag, Travel Bag, Protection Bag, System Controller Neck Strap, holster vest, and belt attachment accessory) for damage or wear.
- Inspect the HeartMate battery holster for damage or wear.
- Inspect the HeartMate Shower Bag for damage or wear.
- REPLACE ANY EQUIPMENT COMPONENT THAT APPEARS DAMAGED OR WORN.

Monthly Safety Checklist

- Review Alarms and Troubleshooting guides in Section 7.
- Check the expiration date of the 11 Volt Lithium-Ion backup battery by following the steps below:
 1. Ensure that you advise all HeartMate 3™ LVAS patients to bring their backup System Controller with them to all clinic visits.
 2. Use the HeartMate Touch™ App to check the expiration date of the 11 Volt Lithium-Ion backup battery within the patient's primary and backup System Controllers.
 3. The remaining months until the 11 Volt Lithium-Ion backup battery will expire is displayed on the backup battery information screen on the HeartMate Touch App (review the *System Controller Backup Battery Power* on page 2-39).

Note: The number of months remaining until the backup battery will expire is displayed on the HeartMate Touch App as "Replace in XX month(s)". The number of months remaining until expiration is a number between 36 (maximum) and 0 (expired).

Once the number of months remaining reaches 6 months or less, the number will be highlighted to remind Hospital Staff to replace the backup battery. Depending upon a patient's clinic schedule, replacement of the 11 Volt Lithium-Ion backup battery should be considered when less than 6 months remain before the mandatory replacement date (see *Replacing a Backup Battery in the System Controller* on page 2-40).

WARNING !

Failure to replace the 11 Volt Lithium-Ion backup battery prior to its expiration date will result in an Advisory alarm (see *System Controller Backup Battery Fault Alarm* on page 7-21) at 12:00 am (midnight) on the first day of the month in which the actual expiration date is reached, which could potentially lead to **serious injury to the patient or patient death**. It is critical that the clinician regularly check the backup battery expiration date and replace the backup battery as required (see *Replacing a Backup Battery in the System Controller* on page 2-40).

- Check the manufacture date on the label of all batteries. If a battery was manufactured more than three years ago, the battery has expired. Replace expired batteries. Do not use expired batteries.

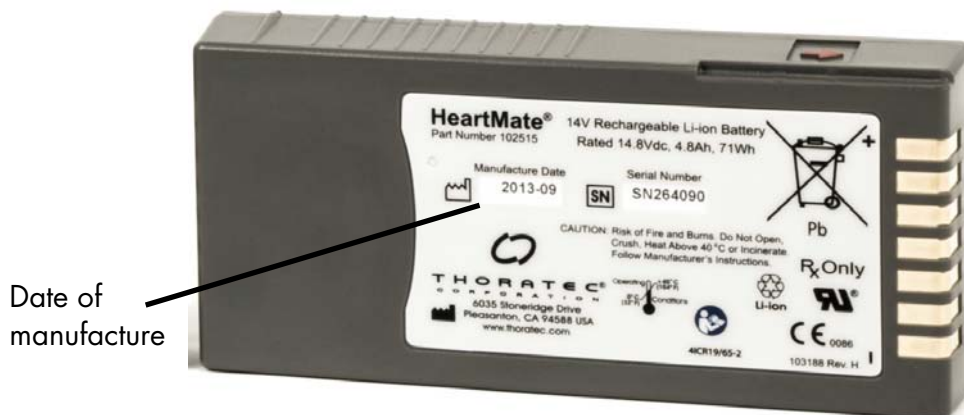

Figure F.2 Check the Manufacture Date to Determine Battery Expiration

- Check the number of use/charge cycles for each battery. Insert a battery into the Battery Charger to read the number of cycles. The cycle information is displayed on the charger's display panel screen (see *Battery Charger Display Panel Messages* on page 7-44). Replace batteries that have exceeded 360 cycles. Do not use batteries that have exceeded 360 cycles.
- Clean the metal battery contacts and the interior contacts of battery clips using a cotton swab or lint-free cloth that has been moistened (not dripping) with rubbing alcohol. Allow the alcohol to completely air dry before using newly cleaned batteries or clips. Do not clean batteries while the batteries are in use.
- Inspect the Power Module patient cable or Mobile Power Unit patient cable and power cable connector pins and sockets for dirt, grease, or damage. If the pins or sockets are damaged or contaminated, do not attempt to clean them. Report the condition to Abbott. For Abbott contact information see the *Back Cover* of this manual. Cleaning and service should be performed only by Abbott-trained personnel. Do not attempt to clean or repair equipment on your own.
- If the Mobile Power Unit will be stored for more than one month, remove the Mobile Power Unit batteries.

- Unplug the Battery Charger and clean the metal contacts inside all four charging pockets with a lint-free cloth or swab that has been moistened (not dripping) with rubbing alcohol. Allow the alcohol to completely air dry before inserting batteries into the pockets. Do not clean the Battery Charger while it is plugged in.
- REPLACE ANY EQUIPMENT OR SYSTEM COMPONENT THAT APPEARS DAMAGED OR WORN.

FOR HOSPITAL STAFF ONLY: Use the HeartMate Touch App to check the expiration date and battery usage on the 11 Volt Lithium-Ion backup battery.

Six Month Safety Checklist

- Depending upon the patient's clinic schedule, once in a six month period the backup System Controller must be maintained and assessed for readiness (see **System Controller Power Cable Connectors** on page 2-26). This involves:
 - Connect the backup System Controller to a power source (Power Module, Mobile Power Unit, or two HeartMate™ 14 Volt Lithium-Ion batteries). Connection to power allows charging of the backup System Controller's 11 Volt Lithium-Ion backup battery.
 - Perform a self test on the backup System Controller, after the System Controller is connected to power.
 - Using a HeartMate Touch™ App, verify that the correct date and time have been programmed into the backup System Controller.
- Replace the Mobile Power Unit batteries with three new Alkaline AA batteries. If corrosion is observed, report the condition to Abbott. Refer to the *Back Cover* of this manual for Abbott contact information. Cleaning and service should be performed only by personnel trained by Abbott.
Do not attempt to clean or repair equipment on your own.

- Practice and evaluate your patient's ability to perform necessary care skills. Advise your patient to bring his or her Patient Handbook to the clinic visit.
 - Review how to identify an emergency (see Patient Handbook section 8, "What is an Emergency?").
 - Review emergency contact list (see Patient Handbook "Emergency Contact List" on page v).
 - Review replacing the running System Controller with a backup System Controller (see **Replacing the Current System Controller** on page 2-54 or Patient Handbook section 2). With demonstration equipment, both the patient and primary caregiver must be able to repeatedly demonstrate the ability to successfully complete the connection of a driveline to the System Controller in a timely manner.
 - Review changing power sources (see **Switching Power Sources** on page 3-66 or Patient Handbook section 3).
 - Review System Controller alarms and troubleshooting including Hazard and Advisory alarm handling and accessing alarm history on the System Controller (see **System Controller Alarms** on page 7-2 or Patient Handbook section 5).
 - Review Power Module alarms and troubleshooting (see **Handling Power Module Alarms** on page 7-37).
 - Review Mobile Power Unit alarms and troubleshooting (see **Mobile Power Unit Alarms** on page 7-40 or Patient Handbook section 5).
 - Review how to replace the Modular Cable (if applicable).
 - Review guidelines for connecting power cable connectors (see **Guidelines for Power Cable Connectors** on page 7-45 or Patient Handbook section 5).
 - Review HeartMate 14 Volt Lithium-Ion battery calibration steps (see **Calibrating HeartMate Batteries** on page 3-84 or Patient Handbook section 3).
 - Review **What Not To Do: Driveline and Cables** on page 7-46 or Patient Handbook section 5.
 - Review using the Shower Bag and showering (see **Using the Shower Bag** on page 6-13 or Patient Handbook section 4).
 - Review caring for the Driveline exit site including cleansing, dressing, and immobilizing the Driveline (see **Caring for the Driveline Exit Site** on page 6-7 or Patient Handbook section 4) (if applicable).

Yearly Safety Checklist

- Schedule a Power Module inspection and cleaning with Abbott-trained personnel. The inspection and cleaning includes (but is not limited to) functional testing, cleaning, inspection, and replacement of the Power Module backup battery.
- Schedule a Battery Charger inspection and cleaning with Abbott-trained personnel. The safety inspection and cleaning includes (but is not limited to) functional testing, cleaning, and inspection.
- REPLACE ANY EQUIPMENT OR SYSTEM COMPONENT THAT APPEARS DAMAGED OR WORN.

WARNING !

Ensure that the Power Module backup battery is reconnected after service or shipping. Refer to ***Installing the Power Module Backup Battery*** on page 3-8.

As-Needed Safety Checklist

- Clean the exterior surfaces of batteries using a clean, dry cloth. Do not use liquids such as water or liquid cleaning solvent to clean batteries. Keep batteries dry and away from water or liquid.
- Unplug the Battery Charger and clean the exterior surfaces using a clean, damp (not wet) cloth. You may use a mild, non-abrasive cleaner, if necessary. Do not submerge the charger in water or liquid.
- REPLACE ANY EQUIPMENT OR SYSTEM COMPONENT THAT APPEARS DAMAGED OR WORN.

Clinic Visit Safety Checklist

Advise your patient to bring his or her Patient Handbook to the clinic visit. The following safety check should be performed at each clinical follow-up visit:

- Review replacing the running System Controller with a backup System Controller (IFU Section 2 or *Patient Handbook* Section 2).
- With demonstration equipment, both patient and primary caregiver must be able to repeatedly demonstrate ability to successfully complete connection of a driveline to the Pocket Controller in a timely manner (IFU Section 2 or *Patient Handbook* Section 2).

Evaluate, and if necessary, review your patient's ability to perform the following core skills:

- Review System Controller alarms and troubleshooting including Hazard and Advisory alarm handling and accessing alarm history on the System Controller (IFU Section 7 or *Patient Handbook* Section 5).
- Review Power Module and/or Mobile Power Unit alarms and troubleshooting (IFU Section 7 or *Patient Handbook* Section 5).
- Remind the patient to follow all hazard and advisory alarm instructions, for example, call the hospital when the System Controller instructs the patient to do so.
- Review how to identify an emergency (*Patient Handbook* Section 8).
- Review emergency contact lists (*Patient Handbook* page v).
- Review guidelines for connecting power cable connectors (IFU Section 3 or *Patient Handbook* Section 5).
- Review changing power sources (IFU Section 3 or *Patient Handbook* Section 3).
- Review HeartMate™ 14 Volt Lithium-Ion battery calibration steps (IFU Section 3 or *Patient Handbook* Section 3).
- Review *What Not To Do: Driveline and Cables* on page 7-46 or *Patient Handbook* section 5.
- Review using the Shower Bag and showering (see page 6-13 or *Patient Handbook* section 4).
- Review caring for the driveline exit site including cleansing, dressing, and immobilizing the driveline.
- System Controller must be maintained and assessed for readiness (IFU Section 2).

GLOSSARY

This section provides a glossary of terms for the HeartMate 3™ Left Ventricular Assist System.

Abbreviations - - - - - G-2

Terms - - - - - G-3

Abbreviations

Abbreviation	Term
AC	Alternating Current
CM	Centimeter
DC	Direct Current
EKG	Electrocardiogram
ESD	Electrostatic Discharge
FML	Fully Magnetically Levitated
ICD	Implantable Cardiac Defibrillators
ICU	Intensive Care Unit
IMP	Implantable Pacemaker
INR	International Normalized Ratio
IV	Intravenous
LPM	Liters Per Minute
LVAD	Left Ventricular Assist Device
LVAS	Left Ventricular Assist System
LMW	Low Molecular Weight
ml/hr	Milliliter per hour
MRI	Magnetic Resonance Imaging
OR	Operating Room
PI	Pulsatility Index
PTT	Partial Thromboplastin time
QD	Once daily
RPM	Revolutions Per Minute
TID	Three times daily
V	Volt

Terms

A

Advisory Alarm: Alarms that are important, but not life threatening. Advisory alarms can be silenced for a short time using the Silence Alarm button that is found on the System Controller user interface. See *System Controller Alarms* on page 7-2.

Alarm: A sound, light, or lighted symbol that tells users about a problem that may affect system operation or cause harm. See *System Controller Alarms* on page 7-2.

Alternating Current: Abbreviated AC. The type of electricity that is common for electrical outlets in North American households.

Apical Cuff: The Apical Cuff is the interface between the heart and the HeartMate 3™ LVAD. It is sewn to the exterior of the heart and anchors it to the LVAD via the slide lock.

B

Backup System Controller: A backup System Controller used to replace the running System Controller, if needed. The backup is identical to the running System Controller and is pre-set with the same settings. A patient should keep their backup System Controller with them at all times (along with other emergency or backup items). The 11 Volt Lithium-Ion backup battery inside the backup System Controller must be recharged every 6 months. See *Maintaining Backup System Controller Readiness: Six Month Charging and Self Test* on page 2-51.

Battery: A device that provides direct current (DC) power to the system. The HeartMate 3 Left Ventricular Assist System can be powered by a pair of 14 Volt Lithium-Ion batteries. See *Using HeartMate 14 Volt Lithium-Ion Batteries* on page 3-51. An 11 Volt Lithium-Ion battery inside the System Controller gives at least 15 minutes of backup power to the system if the main source of power is disconnected or fails. See **The Backup System Controller** on page 2-45.

Battery button: A button on the System Controller user interface that shows a small battery symbol. Depending on the mode of operation, pressing this button either: 1) works the battery power gauge on the System Controller, 2) starts the System Controller self test, 3) puts the battery to “sleep” for storage purposes, or 4) recharges the System Controller’s 11 Volt Lithium-Ion backup battery. See *Performing a System Controller Self Test* on page 2-29.

Battery Charger: A device that charges, calibrates, and tests the HeartMate™ 14 Volt Lithium-Ion batteries that are used to power the HeartMate 3 Left Ventricular Assist System.

Battery Power Gauge: A set of lighted bars that indicate how much battery power is available. Each HeartMate 14 Volt Lithium-Ion battery has its own 5-light on-board battery power gauge that shows the battery charge level. The System Controller also has a battery power gauge. The power gauge on the System Controller has four bars and one diamond-shaped light. The System Controller battery power gauge is used during battery-powered operation. It shows the approximate charge level of the two batteries currently in use.

Battery-Powered Operation: Using two HeartMate 14-V Lithium-Ion batteries to power the system. Using batteries to power the system is appropriate when users are active, outdoors, or when electrical power is unavailable.

C

Cautions: Actions to avoid that could damage equipment or affect how the system works. Although important for system function, cautions do not usually relate to life-threatening risks.

Communication Fault (Comm Fault): An Advisory alarm indicating the HeartMate 3 LVAD and System Controller cannot properly exchange information. See *Communication Fault Alarm* on page 7-20.

Controller Alarm Fault: An advisory alarm that occurs when an internal malfunction in the System Controller has occurred that requires clinician diagnosis and resolution.

Controller Driveline Connector: Connector permanently attached to the Driveline that connects the pump to the System Controller.

D

Direct Current: Abbreviated DC. The type of electricity that comes from a battery. The HeartMate 3 system uses two types of DC power: either 1) two 14 Volt Lithium-Ion batteries, or 2) an automobile power outlet.

Display button: A button on the System Controller user interface. Press this button () to bring up data on the user interface's display screen (such as current function and alarm history). See *System Controller User Interface Components* on page 2-15.

Driveline: The Driveline connects the pump to the System Controller, which then connects to a power source. The Driveline consists of two cables: the Pump Cable and the Modular Cable. One end of the Pump Cable connects to the pump implanted in the patient's abdomen. The other end of that cable exits the patient's body. One end of the Modular Cable is connected to the Pump Cable and the other end connects to the System Controller. The Driveline brings power to the motor inside the implanted pump. Data about system operation is transferred through the Driveline to the System Controller.

Driveline Communication Fault (Driveline Comm Fault): An Advisory Alarm. It occurs when one of the communication wires inside the Driveline is damaged.

Driveline Power Fault: An Advisory Alarm. It occurs when one of the power wires inside the Driveline is damaged.

E

Exit Site: The place where the Driveline goes through the skin. The exit site must be kept clean and dry to lower the risk of infection.

Extended Alarm Silence: Allows the audio portion of the alarm to be silenced in order to allow the user to troubleshoot the situation without the audio alarm present.

F

Fixed Speed Mode: An operating mode where the pump is set at a constant or “fixed” speed. Doctor and nurses decide and control pump speed.

Flash Drive: The Flash Drive has a Lightning connector and USB connector. The Flash Drive is used for exporting, transferring, and storing data generated from the HeartMate Touch App.

Fully Magnetically Levitated (or Full Mag Lev, or FML): The electrical system that suspends the pump rotor and maintains rotor position within the motor.

G

H

Hazard Alarm: Hazard alarms occur when the pump has stopped working or is about to stop working. Hazard alarms are serious conditions that require immediate attention. Hazard alarms are indicated by a red light and continuous audio tone.

HeartMate 3 Left Ventricular Assist System: Includes the implanted pump and Driveline (including the Modular Cable), as well as the System Controller, power sources (Power Module, Mobile Power Unit, or batteries), and accessories. You may sometimes hear the term “LVAS,” which is short for Left Ventricular Assist System.

HeartMate Touch App: The HeartMate Touch App provides clinicians with the ability to wirelessly monitor a patient’s HeartMate system, program system parameters such as pump speed, assess and track alarm conditions, and view and save performance data.

HeartMate Touch Communication System: The HeartMate Touch Communication System gives clinicians a detailed, large-scale display of system performance. Using the HeartMate Touch Communication System, clinicians can also enter and change operating parameters and system settings.

HeartMate Touch Wireless Adapter: The HeartMate Touch Wireless Adapter facilitates Bluetooth® pairing, when it is connected to the Power Module.

I

Inflow Cannula: A small tube that connects the pump to the left ventricle of the heart.

Intensive Care Unit: Abbreviated ICU. This special hospital unit is where new Left Ventricular Assist System patients receive intensive care, usually just after pump implant.

J

K

L

Left Ventricular Assist Device: The implanted device connected to the left ventricle of the heart that sends blood taken from the Inflow Cannula through the Outflow Graft and into the aorta, which sends the blood to the rest of the body. The motor inside the device is powered through the Driveline. You may sometimes hear the device called a “pump,” “heart pump,” or “LVAD,” which is short for Left Ventricular Assist Device.

Left Ventricular Assist System: The HeartMate 3 Left Ventricular Assist System includes the implanted pump and all related external equipment. Sometimes the Left Ventricular Assist System is called an “LVAS”. LVAS is not the same as LVAD, which refers only to the implanted pump.

Liters Per Minute: Abbreviate LPM. Blood flow through the pump is measured in LPMs. “LPM” shows on the System Controller user interface along with blood flow data.

Low Battery Hazard Alarm: A red battery-shaped symbol () on the System Controller user interface that illuminates when less than 5 minutes of combined battery power remain for the in-use HeartMate 14 Volt Lithium-Ion batteries, during battery-powered operation.

Low Battery Hazard Symbol: Red “battery” light () on the System Controller. It lights when power to the System Controller is critically low.

Low Flow Alarm: Blood flow is less than 2.5 lpm. This condition is accompanied by a flashing red heart on the user interface. “Call Hospital Contact” and “Low Flow” alternate on the screen, and there is a constant audio tone emitting from the System Controller. This is a Hazard alarm condition that requires immediate attention.

Low Flow Hazard Symbol: Red “heart” light () on the System Controller. It lights when HeartMate 3 pump blood flow is critically low.

Low Speed Limit: The lowest speed at which the HeartMate 3 pump can operate while maintaining patient stability.

LPM: Short for liters per minute (lpm). Blood flow through the pump is measured in lpm.

LVAD Fault: An advisory alarm that occurs when the LVAD has determined that one or more internal LVAD operating conditions are out of range.

LVAS: Short for Left Ventricular Assist System. The HeartMate 3 Left Ventricular Assist System includes the implanted pump and Driveline, as well as the System Controller, power sources (Power Module, Mobile Power Unit, or batteries), and accessories.

M

Mobile Power Unit: The Mobile Power Unit connects to an AC electrical outlet. It provides AC electrical power to the Left Ventricular Assist System. Patients must always connect to the Power Module or Mobile Power Unit for sleep (or when sleep is possible). Connecting to the Mobile Power Unit is also appropriate when patients are stationary or relaxing indoors. See *Using the Mobile Power Unit* on page 3-34.

Modular Cable: One of the two cables that make up the Driveline. One end of the Modular Cable connects to the Pump Cable that exits the patient's abdomen. The other end of the Modular Cable connects to the System Controller.

Modular Inline Connector: The electrical connection between the Pump Cable and the Modular Cable.

Modular Cable Cap: The protective cap that covers the Modular Connector on the Modular Cable from fluid ingress during LVAD implantation. The Pump Cable contains wires that carry power and data to the pump, and that control and monitor pump operation.

N

O

Operating Modes: There are three modes of System Controller operation: 1) Run Mode (actively running), 2) Sleep Mode (off and unused), and 3) Charge Mode (connected to power and charging the internal backup battery). See *System Controller Operating Modes* on page 2-33.

Outflow Graft: The polyester tube that connects the pump to the aorta (the large blood vessel that sends blood through the body).

Outflow Graft Clip: A clip attached to the outflow assembly to prevent post-operative outflow twist.

P

Percutaneous: "Percutaneous" means "through the skin." This term describes the Driveline that goes through the skin of the abdomen and connects the implanted pump to the System Controller.

Pump Cable: One of the two cables that make up the Driveline. The Pump Cable is permanently attached to the pump housing. The other end of the Pump Cable exits the patient's abdomen and is connected to the Modular Cable which connects to the System Controller.

The Pump Cable contains wires that carry power and data to the pump, and that control and monitor pump operation.

Polyester Velour: A synthetic biocompatible material that lets skin tissue grow into the soft covering of the Driveline. This material covers the Driveline inside the body at the exit site and is on the external portion of the Pump Cable. Skin growth into the velour covering helps create a barrier that reduces the risk of Driveline infections.

Power Cable: A cable containing electrical wires that transfers electrical power to the System Controller from a routine power source (two 14 Volt Lithium-Ion batteries or the Power Module or the Mobile Power Unit).

Power Module: The Power Module connects to an AC electrical outlet. It provides AC electrical power to the Left Ventricular Assist System. Patients must always connect to the Power Module or the Mobile Power Unit for sleep (or when sleep is possible). Connecting to the Power Module is also appropriate when patients are stationary or relaxing indoors. See *Using the Power Module* on page 3-4.

Power Module Backup Battery: A backup power source inside the Power Module that gives up to 30 minutes of support if power to the Power Module fails or is disconnected. The backup battery works only if it is charged and properly connected. See *Setting Up the Power Module Before Use* on page 3-8.

Power Saver Mode: In power saver mode, the System Controller slows pump speed to save power. If power is removed or fails, the System Controller gives 15 minutes of full power before entering power saver mode. Alarms cannot be silenced while in power saver mode. See *System Controller Alarms* on page 7-2.

Power Sources: Three power sources can power the HeartMate 3 Left Ventricular Assist System: 1) a pair of wearable, rechargeable 14 Volt Lithium-Ion batteries worn in battery clips, or 2) the Power Module that plugs into an AC electrical outlet, or 3) the Mobile Power Unit that plugs into an AC electrical outlet.

Pulsatility Index (PI): Pulsatility Index (PI) is a calculation related to the amount of assistance provided by the pump. PI values typically range from 1 to 10. Higher values indicate more ventricular filling and higher pulsatility (ie, the pump is providing less support to the left ventricle). Lower values indicate less ventricular filling and lower pulsatility (ie, the pump is providing greater support and further unloading the ventricle).

Pulse Mode: The HeartMate 3 LVAS automatically develops an induced pulse X times per minute by increasing/decreasing rotor speed in a rapid fashion. The (▲) symbol indicates the pump is operating in Pulse Mode.

Pump Running Symbol: A green symbol (🔄) on the System Controller user interface that illuminates when the pump is receiving power and running.

Pump Speed: Pump speed is measured in revolutions per minute (RPM). The number of RPMs reflects how fast the pump's internal rotor turns.

Q

R

Red Heart Indicator: A red heart shaped symbol (❤️) on the System Controller user interface that illuminates during a hazard alarm condition. Red heart alarms occur for conditions that are immediately life-threatening. Red heart alarms should prompt an immediate response to avoid serious patient injury or death.

Revolutions Per Minute: Abbreviated RPM. The number of RPMs reflects how fast the pump's internal rotor turns.

Running System Controller: The System Controller that is currently in use and connected to the implanted pump.

S

Safety Lock: The feature on the System Controller that ensures the System Controller Driveline Connector is properly inserted (when the lock can be fully closed).

Self Test: A routine system check performed daily by the patient to confirm that the System Controller's audio and visual alarms are working properly.

Silence Alarm button: A button on the System Controller (☒) or Power Module (☒) that silences an audio alarm. How long the alarm is silenced depends on the type of alarm. The silence period varies from 2 minutes to 4 hours.

IMPORTANT! Pressing the Silence Alarm button only silences the alarm. It does not fix the alarm condition. See *System Controller Alarms* on page 7-2.

Slide Lock: The mechanical feature on the HeartMate 3 LVAD that affixes the pump to the Apical Cuff.

Strap Attachment Points: Four places on the System Controller where straps can be easily connected. Attachment points allow for holding or carrying the System Controller. The System Controller can be worn or carried on a belt or strap, or inside a pocket. See *Wearing and Carrying System Components* on page 6-26.

System Controller: The small computer that controls and checks system function. It connects the implanted pump to the external power sources. It can be worn on a strap around the neck, on a belt, or in a carrying case.

System Controller 11 Volt Lithium-Ion Backup Battery: A backup power source inside the System Controller. It powers the system for up to 15 minutes if the main power source fails or is disconnected. The 11 Volt Lithium-Ion backup battery is rechargeable. It charges automatically any time the System Controller is connected to a power source (Power Module, Mobile Power Unit, or batteries). The backup battery inside the backup System Controller must be recharged once every six months. Although rechargeable, the 11 Volt Lithium-Ion backup battery has a limited life (36 months from manufacture date). A message on the System Controller screen tells you when it is time to replace the 11 Volt Lithium-Ion backup battery. See *System Controller Backup Battery Power* on page 2-39.

System Controller Battery Power Gauge: A set of four bars on the System Controller. The bars show the approximate charge level for a pair of batteries being used to power the system. Four green bars mean the batteries are between 75-100% charged. One green bar means the batteries are less than 25% charged. A yellow diamond-shaped light means that only 15 minutes of battery power remain. If the yellow diamond comes on, promptly replace the depleted batteries or switch to the Power Module or the Mobile Power Unit. Failure to replace batteries or switch to the Power Module or the Mobile Power Unit may cause the implanted pump to stop. See *Performing a System Controller Self Test* on page 2-29.

System Controller Power Cables: Two power cables (one with a black connector and one with a white connector) connect the System Controller to its power source (batteries, Power Module, or Mobile Power Unit). Both cables provide equal power. However, the white cable contains a data link that sends information to the Power Module.

T

Tablet with the HeartMate Touch App: The Tablet deployed with HeartMate Touch App serves as the display screen and is installed in a protective case.

Tethered Operation: Refers to using the HeartMate 3 Left Ventricular Assist System while connected to an electrical outlet via the Power Module or the Mobile Power Unit.

U

User Interface: Set of visual indicators (symbols that illuminate) and buttons located on the front of the System Controller.

User Interface Screen: The screen on the System Controller that allows users to view real-time data about system operation. Alarm information and instructions also appear on the screen. See *Performing a System Controller Self Test* on page 2-29.

V

W

Warnings: Hazards that could cause serious harm or death if not avoided. If you ignore a warning, you could be seriously harmed or killed.

Wear and Carry Accessories: Wear and carry accessories are used to safely hold or carry the System Controller. For example, you can carry the System Controller with a strap around your neck, on a belt, or in a pocket. A battery holster is used for carrying batteries and battery clips. See the *Wearing and Carrying System Components* on page 6-26.

X

Y

Yellow Diamond Indicator: A yellow symbol on the System Controller user interface that illuminates when less than 15 minutes of combined battery power remain from the in-use HeartMate 14 Volt Lithium-Ion batteries that are providing power during battery-powered operation.

Yellow Wrench Indicator: A yellow symbol () on the System Controller user interface that illuminates during alarm conditions that are important, but not immediately life-threatening.

Z



United States & Canada



Thoratec Corporation
6035 Stoneridge Drive
Pleasanton, CA 94588
USA
Telephone: +1-925-847-8600
Fax: +1-925-847-8574
Note: Thoratec is now part of Abbott

R_x Only

Document: 100167126.B

Publication Date: 07/2020

