

HeartWare™ HVAD™ System

Instructions for Use



HeartWare®

R_xonly

+ Table of Contents

1.0	Introduction.....	1
1.1	Introduction	2
1.2	Indications for Use.....	2
1.3	Contraindications	2
1.4	⚠ Warnings	3
1.5	⚠ Precautions	7
1.6	Potential Complications.....	10
1.7	Pivotal US Clinical Study: Bridge-to-Transplant	11
1.8	US Clinical Study: Destination Therapy	20
1.9	Destination Therapy Supplemental Study.....	38
1.10	North American Clinical Study: LATERAL.....	50
2.0	HeartWare™ HVAD™ System Overview.....	61
2.1	HVAD® Pump and Surgical Tools.....	61
2.2	HVAD® Controller	62
2.3	HeartWare® Monitor.....	63
2.4	HVAD® Controller Power Sources.....	63
2.5	HeartWare® Battery Charger	64
2.6	Carrying Cases and Shower Bag	64
3.0	HeartWare™ HVAD™ System Pump.....	67
3.1	Principles of Operation.....	67
3.2	Physiologic Control Algorithms.....	69
3.2.1	Flow Estimation	69
3.2.2	[Ventricular Suction Detection] Alarm	70
3.2.3	Lavare™ Cycle.....	72
3.3	HVAD® Pump Operating Guidelines.....	73
3.4	Expected Useful Life of the HVAD® Pump	73
3.5	Device Tracking and Reporting Requirements	73
4.0	HeartWare™ HVAD™ System Peripherals and Accessories.....	75
4.1	HVAD® Controller Connections	75
4.2	HVAD® Controller.....	79
4.3	Using the HeartWare® Batteries	83
4.4	Using the HeartWare® Battery Charger	89
4.5	Using the HVAD® Controller AC Adapter or DC Adapter	92
4.6	Carrying Cases	93
4.7	Recommended Equipment for Use at Home	94

5.0	Using the HeartWare® Monitor	95
5.1	General Overview	95
5.2	Informational Screens.....	97
5.3	System Screens.....	99
5.4	Downloading Controller Log Files	110
5.5	Updating Software on the HVAD® Controller	111
5.6	Monitor Shutdown.....	115
5.7	HeartWare® Monitor Care.....	116
6.0	Surgical Implant and Explant of the HVAD® Pump.....	119
6.1	Preparing for Implantation	119
6.2	Programming HVAD® Controllers	121
6.3	HVAD® Pump Pre-Implant Test and Pump Assembly	123
6.4	Surgical Implant Procedure	127
6.5	HVAD® Pump Explant	133
7.0	Patient Management and Education	135
7.1	Postoperative Management.....	135
7.1.1	Setting Speed with HVAD® Pump	136
7.1.2	Blood Pressure Maintenance	137
7.1.3	Anticoagulation.....	137
7.1.4	Right Heart Failure.....	138
7.1.5	Arrhythmias.....	138
7.1.6	Infection Control Guidelines.....	138
7.2	Driveline Care.....	139
7.3	Emergency Management	140
7.4	Physical Rehabilitation	140
7.5	Patient Education	140
8.0	HeartWare™ HVAD™ System Alarms and Emergencies.....	141
8.1	Alarm Overview	141
8.2	High Priority Alarms.....	142
8.3	Medium Priority Alarms.....	144
8.4	Low Priority Alarms	146
8.5	Multiple Alarms.....	147
8.6	How to Silence (Mute) Alarms.....	148
8.7	How to Change the Controller.....	149
9.0	Quick Reference Guide for Alarms.....	153
10.0	Appendix.....	157
	Appendix A System Components.....	157
	Appendix B Product Specifications	158
	Appendix C EMC Manual Requirements Guidance Document	160
	Appendix D Symbol Definitions	164

+ 1.0 Introduction

- 1.1** Introduction.....**2**
- 1.2** Indications for Use.....**2**
- 1.3** Contraindications**2**
- 1.4** Warnings**3**
- 1.5** Precautions.....**7**
- 1.6** Potential Complications..... **10**
- 1.7** Pivotal US Clinical Study: Bridge-to-Transplant..**11**
- 1.8** US Clinical Study: Destination Therapy....**20**
- 1.9** Destination Therapy Supplemental Study...**38**
- 1.10** North American Clinical Study: LATERAL**50**

Foreword





The HeartWare™ HVAD™ System is indicated for use under the direct supervision of a licensed healthcare practitioner or by personnel trained in its proper use. Clinical users include physicians, registered nurses, perfusionists and biomedical engineers. Implant of the device must be performed by a qualified cardiac surgeon trained by HeartWare-authorized personnel. Clinical users of the HeartWare™ HVAD™ System should attend HeartWare training, should have a working knowledge of the principles of ventricular assist devices (VADs), and should be aware of the physical and psychological needs of patients undergoing VAD support. Patients and caregivers should complete a user training program and demonstrate their ability to use the system prior to independence.

Clinicians should read the entire Instructions for Use before system operation. This manual may serve as a reference for detailed information including specific information on device function, system setup, implant and maintenance. This manual is not intended to replace comprehensive educational programs or to supersede acquired knowledge or proper medical judgment.



1.0 Introduction

In this manual, there will be the following symbols:

 <p>Indicates there is more information available in the manual and the location in the manual</p>	 <p>Identifies information as a Warning A Warning is a statement about the possibility of injury, death or other serious adverse reaction that is associated with the use or misuse of the device</p>	 <p>Identifies information as a Caution or Precaution A Caution is a statement that not following the instruction may lead to device misuse, malfunction or damage</p>	 <p>Indicates there is a quick reference guide available</p>
---	--	--	---



WARNING! Carefully read this entire manual prior to implanting or operating the device. Improper operation of the system and potential harm to the patient and to the user could result.

1.1 Introduction

The HeartWare™ HVAD™ System is designed to assist a weakened, poorly functioning left ventricle. The HeartWare™ HVAD™ System is designed for in-hospital and out-of-hospital settings, including transportation via fixed wing aircraft or helicopter. The HeartWare™ HVAD™ System utilizes a centrifugal blood pump, the HVAD® Pump (the “pump”), which is implanted in the pericardial space with left ventricular apex to ascending aortic cannulation for left ventricular support. The inflow conduit, which is partially sintered, is integrated with the pump and a 10 mm gel impregnated outflow graft with a strain relief is attached to the pump. A percutaneous driveline connects the pump to an external controller. The controller, powered by two batteries or by one battery and electricity from a wall or car outlet, regulates pump function and monitors the system. The monitor is used to display system performance and to change controller operating parameters. A battery charger is also included.

All components of the HeartWare™ HVAD™ System are designed to be used only in conjunction with each other. They are neither compatible nor intended to be used with other manufacturer's devices.

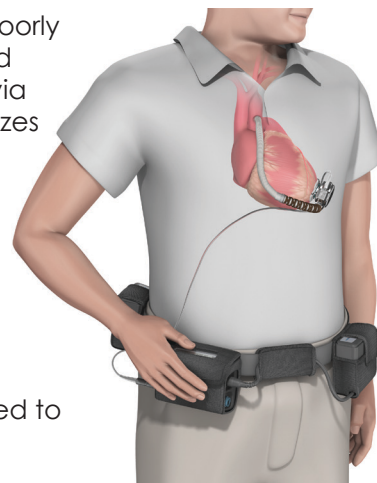

Figure 1:
HeartWare™ HVAD™ System

1.2 Indications for Use

The HeartWare™ HVAD™ System is indicated for hemodynamic support in patients with advanced, refractory left ventricular heart failure; either as a Bridge to Cardiac Transplantation (BTT), myocardial recovery, or as Destination Therapy (DT) in patients for whom subsequent transplantation is not planned.

1.3 Contraindications

The HeartWare™ HVAD™ System is contraindicated in patients who cannot tolerate anticoagulation therapy.

1.4 Warnings



WARNINGS

1. **WARNING!** Serious and life threatening adverse events, including stroke, have been associated with use of this device. The risk of death as a result of stroke has been observed in randomized clinical trials to be higher with the HVAD than with alternative treatment options. The HVAD has been associated with a rate of stroke of 22% at one year and 29.7% at two years. A blood pressure management protocol may reduce the overall incidence of stroke to 16.9% at one year and may reduce the incidence of disabling strokes at one year from 8.1% to 6.5%. A user must fully consider the risks of this device with that of other treatment modalities before deciding to proceed with device implantation. Please refer to section 1.8 ("Safety and Effectiveness Results") for a summary of the stroke data. To mitigate the risk of stroke, please adhere to the following patient management guidelines:
 - Monitor and treat mean arterial pressure. Maintain MAP less than 85 mmHg as tolerated.
 - Speed on the HVAD® Pump should be set to maintain adequate pump flow index, this generally does not need exceed 2.6 L/min/m².
 - Maintain anticoagulation within the recommended INR range of 2.0-3.0.
 - Daily aspirin dose should be > 81 mg and platelet inhibition should be evaluated and adjust ASA mono-therapy accordingly or consider combination therapy such as ASA 81 mg plus Aggrenox® (ASA plus extended -release dipyridamole) or daily ASA 81 mg plus Plavix 75 mg.
2. **WARNING!** Carefully read this entire manual prior to implanting or operating the device. Improper operation of the system and potential harm to the patient and to the user could result.
3. **WARNING!** DO NOT use the HeartWare™ HVAD™ System in pregnant women. Any woman receiving an HeartWare™ HVAD™ System who is of childbearing age and sexually active should use a reliable method of birth control. Use of anticoagulants during pregnancy has been associated with birth defects and bleeding.
4. **WARNING!** The Instructions for Use (IFU) is intended to be used by physicians, nurses, and other clinical professionals. Setup and operation of this device should only be undertaken by personnel who have completed an HeartWare™ HVAD™ System product training program. A thorough understanding of technical principles, clinical applications and risks associated with the HeartWare™ HVAD™ System is required before using this product. Failure to understand these principles, applications and risks may result in improper operation of the system and potential harm to the patient or to the user.
5. **WARNING!** ALWAYS connect an AC Adapter to the controller before relaxing or sleeping. Power from an electrical outlet (AC Adapter) provides power for an unlimited period of time.
6. **WARNING!** NEVER disconnect both power sources (batteries and AC or DC adapter) at the same time since this will stop the pump. At least one power source must be connected at all times.
7. **WARNING!** DO NOT allow patients to shower until they have received permission from their clinician to do so. Patients who shower must use the HeartWare® Shower Bag.
8. **WARNING!** DO NOT allow hearing impaired patients to shower unless their caregiver is close by to hear alarms.

1.4 Warnings (continued)



WARNINGS

9. **WARNING!** DO NOT plug the controller into an AC wall outlet during showers; to eliminate the possibility of a severe electrical shock, it should be connected to two batteries.
10. **WARNING!** DO NOT allow patients to take a bath or swim, as this may damage HeartWare™ HVAD™ System components and/or result in driveline exit site infection.
11. **WARNING!** DO NOT submerge HeartWare™ HVAD™ System components in water or other fluid as this may damage them. If this happens, contact HeartWare.
12. **WARNING!** DO NOT allow water or other fluids to enter the controller, power adapters, batteries, battery charger or connectors, as this may damage HeartWare™ HVAD™ System components. If this happens, contact HeartWare.
13. **WARNING!** DO NOT use any components other than those supplied by HeartWare with the HeartWare™ HVAD™ System, as this may affect HeartWare™ HVAD™ System operation.
14. **WARNING!** Damaged equipment should be reported to HeartWare and inspected.
15. **WARNING!** DO NOT rely only on flow estimation to assess cardiac output. An average estimated flow on the monitor or Controller Display of less than 2.0 L/min, or greater than 10.0 L/min may indicate an electrical fault, incorrect hematocrit entry or an occlusion and/or thrombus or other materials (e.g. tissue fragments) in the device. Inaccurate assessment of HVAD® Pump flow may lead to less than optimal treatment.
16. **WARNING!** DO NOT grasp the driveline cable as this may damage the driveline. To remove the driveline from the controller, first pull back the driveline cover then grasp and pull the driveline connector.
17. **WARNING!** DO NOT disconnect the driveline from the controller or the pump will stop. If this happens, reconnect the driveline to the controller as soon as possible to restart the pump.
18. **WARNING!** DO NOT plug the HeartWare® Battery Charger or monitor AC adapter into an electrical outlet which is not properly grounded or you may receive a serious electrical shock.
19. **WARNING!** DO NOT operate the controller in temperatures less than -20°C (-4°F) or greater than 50°C (122°F) or the controller may fail.
20. **WARNING!** AVOID devices and conditions that may induce strong static discharges (e.g., television or computer monitor screens) as electrostatic discharges can damage the electrical parts of the system and cause the VAD to perform improperly or stop.
21. **WARNING!** The HeartWare™ HVAD™ System components should not be used adjacent to or stacked with equipment other than specified in the IFU. If adjacent to or stacked use is necessary, the HeartWare™ HVAD™ System and other equipment should be observed to verify normal operation.
22. **WARNING!** ALWAYS have a back-up controller handy and, whenever possible, a caregiver nearby when changing power sources or controllers. Be watchful for unusual changes in power or flow alarms for a period of time following equipment changes.
23. **WARNING!** DO NOT drop the controller or other equipment. Dropping the controller could cause sudden stoppage of the pump. Dropped equipment should be reported to HeartWare and inspected.
24. **WARNING!** DO NOT disconnect the driveline or power sources from the controller while cleaning it or the pump will stop. If this happens, reconnect the driveline to the controller as soon as possible to restart the pump.

1.4 Warnings (continued)



WARNINGS

25. **WARNING!** NEVER clean the battery charger with the power on, as this may lead to an electrical shock.
26. **WARNING!** AVOID areas with high magnetic forces such as theft detection devices or airport security systems, as this may affect HeartWare™ HVAD™ System operation.
27. **WARNING!** Keep mobile phones at least 20 inches (50 centimeters) away from the controller, as mobile phones may interfere with controller operation.
28. **WARNING!** DO NOT let the patient have a magnetic resonance imaging (MRI) procedure while implanted with the HVAD® Pump. Doing so could cause harm to the patient or could cause the pump to stop.
29. **WARNING!** DO NOT apply high power electrical treatment (e.g., deep tissue heating which can be used for treatment of arthritis and/or some injuries) directly to the patient, as this may affect HeartWare™ HVAD™ System operation.
30. **WARNING!** AVOID therapeutic levels of ultrasound energy, as the device may inadvertently concentrate the ultrasound field and cause harm.
31. **WARNING!** AVOID therapeutic ionizing radiation since it may damage the device. This damage may not be immediately detectable.
32. **WARNING!** ALWAYS investigate, and if possible, correct the cause of any alarm. Silencing an alarm does not resolve the alarm condition.
33. **WARNING!** NEVER clean the monitor with the power on, as this may lead to an electrical shock. DO NOT use alcohol or detergent on the monitor display. Gently wipe the display with a soft, lint free cloth.
34. **WARNING!** The HVAD® Pump may cause interference with AICDs. If electromagnetic interference occurs, it may lead to inappropriate shocks, arrhythmia and possibly death. The occurrence of electromagnetic interference with AICD sensing may require adjustment of lead sensitivity, proximal placement of new leads or replacement of an existing sensing lead.
35. **WARNING!** Keep power connected to the controller after setting up the primary controller to minimize the risk of air embolus during implant. Disconnecting and then reconnecting power will result in the controller starting the pump as soon as the driveline is connected.
36. **WARNING!** DO NOT use if package is damaged or opened. Sterile components are intended for single use only. DO NOT re-sterilize or re-use as this will increase the risk of infection.
37. **WARNING!** ALWAYS check for an audible click when connecting the driveline to the controller or driveline extension cable. Failure to ensure a secure connection may cause an electrical fault.
38. **WARNING!** NEVER turn on the HVAD® Pump in air as this may damage the pump. DO NOT use an HVAD® Pump that was turned on without total submersion in fluid during the pre-implant test and prior to implantation: The HVAD® Pump must be completely submerged in fluid before being turned on.

1.4 Warnings (continued)



WARNINGS

39. **WARNING!** DO NOT implant gel impregnated vascular prostheses in patients who exhibit sensitivity to polyester or materials of bovine origin, as severe reactions may occur.
40. **WARNING!** DO NOT allow the Gelweave™ prostheses non-sterile foil pouch or outer tray to be introduced to the sterile field or the sterile field will be contaminated. Only the innermost tray is sterile.
41. **WARNING!** DO NOT preclot the outflow graft. Preclotting may disrupt the gel matrix, resulting in bleeding. Gelweave™ prostheses are sealed grafts and must not be preclotted.
42. **WARNING!** DO NOT implant the Gelweave™ prostheses more than one month after removal from the foil pouch. This may disrupt the gel matrix, resulting in bleeding.
43. **WARNING!** DO NOT allow anyone but a surgeon, physician's assistant or surgical assistant trained in the procedure to attach the outflow graft to the pump, as a loose graft connection may lead to bleeding and/or an air embolus.
44. **WARNING!** ALWAYS position the clamp screw so that it is located on the inner side of the outflow conduit to avoid tissue irritation or damage.
45. **WARNING!** DO NOT use excessive force when tightening the clamp screw because this could damage the graft clamp or graft clamp screw and a loose connection may result in bleeding and/or an air embolus. Replace components if required.
46. **WARNING!** DO NOT over-loosen the sewing ring's screw or it may fall off the sewing ring and be lost in the sterile field.
47. **WARNING!** DO NOT cut the outflow graft too short or too long, or it may kink. Prior to chest closure, ensure that the graft is not kinked or compressed. A kinked or compressed outflow graft may lead to reduced flow and/or thrombus formation.
48. **WARNING!** DO NOT immerse the Gelweave™ grafts in saline for longer than 5 minutes. Longer periods of soaking in saline may disrupt the gel matrix, resulting in bleeding.
49. **WARNING!** ALWAYS position the driveline exit site so that the tunneler does not contact any vital organs or structures.
50. **WARNING!** DO NOT grasp the driveline and pull as this may damage the driveline. To remove the driveline cap from the driveline, unscrew the outer sleeve, then pull back on the grooved part of the connector.
51. **WARNING!** ALWAYS remove all air from the HVAD® Pump and its conduits to reduce risk of air embolus.
52. **WARNING!** DO NOT de-air the HVAD® Pump when there is inadequate blood volume in the HVAD® Pump or leaks in the inflow/outflow connections, as air may enter the HVAD® Pump and outflow graft resulting in a delay in de-airing and possible air embolism.
53. **WARNING!** At HVAD® Pump explant the percutaneous driveline is not sterile; therefore ensure that the driveline does not contaminate the sterile field.
54. **WARNING!** ALWAYS check the Controller Display for any information regarding an alarm when using loud machinery or in the vicinity of loud noises as the alarms may not be audible.
55. **WARNING!** ALWAYS replace a controller with a blank display or no audible alarms. This condition is predictive of a controller failure.

1.4 Warnings (continued)



WARNINGS

56. **WARNING!** ALWAYS switch to the back-up controller if there is a [Controller Failed] alarm since the HVAD® Pump may not be running.
57. **WARNING!** ALWAYS respond to low battery alarms. Silencing an alarm does not resolve the alarm condition and will eventually deplete the batteries.
58. **WARNING!** DO NOT attach the alarm adapter to a controller connected to the running pump. The alarm adapter silences the [No Power] alarm and should only be attached to a controller that has failed or malfunctioned and is no longer connected to a pump.
59. **WARNING!** ALWAYS keep a spare controller and fully-charged spare batteries available at all times in case of an emergency.

1.5 Precautions



PRECAUTIONS

1. **CAUTION:** Safety and effectiveness in persons less than 18 years of age and in persons with a BSA of less than 1.5 m² have not been established.
2. **CAUTION:** The HeartWare™ HVAD™ System has had limited use in patients with artificial mitral or aortic valves and therefore the risks are currently unknown. Caution should be used in selecting patients with artificial mitral or aortic valves for HeartWare™ HVAD™ System therapy.
3. **CAUTION:** ONLY use HVAD® Controllers on one patient to avoid risks associated with an inadvertent mismatch of controller pump speed settings.
4. **CAUTION:** The HeartWare® Waist Pack and the HeartWare® Shoulder Pack contain magnetic closures. Patients with an internal cardiac defibrillator (ICD) or pacemaker should keep the pack away from their chest, including when sleeping. Per pacemaker and ICD manufacturer guidelines, magnets should be kept at least 6 inches (15 centimeters) away from the pacemaker or ICD (please refer to manufacturer guidelines for additional information).
5. **CAUTION:** DO NOT pull, kink or twist the driveline or the power cables, as these may damage the driveline. Special care should be taken not to twist the driveline while sitting, getting out of bed, adjusting controller or power sources, or when using the shower bag.
6. **CAUTION:** DO NOT attempt to repair or service any components of the HeartWare™ HVAD™ System. If HeartWare™ HVAD™ System equipment malfunctions, contact HeartWare.
7. **CAUTION:** Manual changes to the speed will immediately disable the [Ventricular Suction Detection] alarm. An "Sx Off" will be displayed on the monitor screen below the "Fixed" mode display. The [Ventricular Suction Detection] alarm will have to be re-activated.
8. **CAUTION:** DO NOT enable the [Ventricular Suction Detection] alarm while the patient is in a suction condition. To optimize operation of the suction detection the patient should be hemodynamically stable prior to enabling the [Ventricular Suction Detection] alarm.
9. **CAUTION:** ALWAYS keep all connectors free of liquid, dust and dirt, or the HeartWare™ HVAD™ System may not function as intended.

1.5 Precautions (continued)



PRECAUTIONS

10. **CAUTION:** DO NOT force connectors together without proper alignment. Forcing together misaligned connectors may damage the connectors.
11. **CAUTION:** ALWAYS confirm that the power cables are properly locked on the controller by gently pulling the cable near the controller power connector or the power cables may come loose and result in an alarm or the pump stopping.
12. **CAUTION:** ALWAYS recharge fully depleted batteries within 24 hours to avoid permanent battery damage.
13. **CAUTION:** DO NOT expose batteries to temperatures outside the storage and operational ranges or they may provide less support than usual. To preserve battery life, batteries should be stored at room temperature.

Battery operating and storage temperatures:

 - a. Operating: discharge (normal use with the HeartWare™ HVAD™ System): 0°C to +50°C (+32°F to +122°F). Operation at temperatures below 0°C will temporarily reduce battery capacity but the battery will operate.
 - b. Storage: -20°C to +25°C (-4°F to +77°F). Long term storage outside of this range may permanently reduce the battery capacity. Best condition for storage is at room temperature.
14. **CAUTION:** ALWAYS keep batteries away from children. Children may be harmed by damaged batteries or components.
15. **CAUTION:** DO NOT disassemble, crush, or puncture a battery.
16. **CAUTION:** DO NOT use a damaged battery. Battery function is unknown if the battery is damaged.
17. **CAUTION:** DO NOT short circuit the external contacts on a battery since this may result in battery damage.
18. **CAUTION:** DO NOT touch the fluid if a battery pack is leaking fluid. Dispose of a leaking battery pack. In case of eye contact with fluid, DO NOT rub eyes. Immediately flush eyes thoroughly with water for at least 15 minutes, lifting upper and lower lids, until no evidence of the fluid remains. Seek medical attention.
19. **CAUTION:** DO NOT expose batteries to excessive shock or vibration since this may affect battery operation.
20. **CAUTION:** DO NOT dispose of a battery in fire or water. Dispose of batteries according to federal, state, and local regulations.
21. **CAUTION:** DO NOT place batteries in water or liquid.
22. **CAUTION:** ONLY use the HeartWare® Battery Charger to charge HeartWare® Batteries. Other battery chargers will not charge the batteries and may damage them.
23. **CAUTION:** ALWAYS wait until the “Ready” light turns on to disconnect the battery from the battery charger. If this is not followed over consecutive charging cycles, the Battery Capacity Display will not function properly and may convey misleading battery capacity.
24. **CAUTION:** ALWAYS fully charge the monitor’s internal battery prior to patient use.
25. **CAUTION:** DO NOT allow patients to touch the monitor, as this may lead to the entering of unwanted HeartWare™ HVAD™ System parameters.

1.5 Precautions (continued)



PRECAUTIONS

26. **CAUTION:** DO NOT use the “Set Defaults” button on monitor REF1510 when a controller is connected to a patient. Pressing it will erase all patient VAD parameter information from the controller.
27. **CAUTION:** DO NOT use HeartWare equipment in the presence of a flammable anesthetic mixture with air or with oxygen or nitrous oxide. (NOTE: Flammable anesthetics are typically ether based).
28. **CAUTION:** A back-up controller should always be available and programmed identically to the primary controller.
29. **CAUTION:** DO NOT exert excessive tension or force on the Gelweave™ prostheses as it will damage the polyester fibers and the gelatin impregnation, which may result in bleeding.
30. **CAUTION:** ALWAYS ensure the inflow cannula position is pointed toward the mitral valve and parallel to the interventricular septum to optimize HVAD® Pump operation.
31. **CAUTION:** ALWAYS position the sewing ring to permit access to its screw after cannulation.
32. **CAUTION:** ALWAYS use round body taper point needles when implanting Gelweave™ prostheses to minimize fiber damage. A kinked or compressed outflow graft may lead to reduced flow and/or thrombus formation.
33. **CAUTION:** The driveline connector is made of nickel-coated brass which may cause a rash in patients with a nickel allergy.
34. **CAUTION:** ALWAYS be aware of the position of the driveline to avoid damage by surgical instruments and needles during HVAD® Pump implantation and/or re-operation.
35. **CAUTION:** ALWAYS use the smallest possible needle for de-airing; 19-gauge is normally sufficient. Hypodermic needles have a cutting point which may result in blood leakage and may require repair by suturing.
36. **CAUTION:** DO NOT rely on HVAD® Pump flow estimation during the de-airing procedure. Flow estimation may not be accurate.
37. **CAUTION:** ALWAYS examine the driveline for evidence of tears, punctures or breakdown of any of the material during exit site dressing changes. Driveline damage may affect HeartWare™ HVAD™ System performance.
38. **CAUTION:** DO NOT expose the driveline to direct or indirect sunlight. ALWAYS keep the driveline completely covered when in the sun. Instruct patients not to use tanning lights or black lights. The light from these sources contains ultraviolet radiation which may damage the outer sheath of the driveline.
39. **CAUTION:** DO NOT use prophylactic topical antibiotic ointments such as silver sulfadiazine, povidone iodine (betadine), or polymyxin-neomycin-bacitracin ointment on the exit site. These ointments can injure the tissue next to the driveline.
40. **CAUTION:** Chest compressions may pose a risk due to pump location and position of the outflow graft on the aorta - use clinical judgment. If chest compressions have been administered, confirm function and positioning of HVAD® Pump.
41. **CAUTION:** Speeds below 2400 RPM or above 3200 RPM should be used with caution.
42. **CAUTION:** The safety and effectiveness of the Lavare™ Cycle has not been evaluated clinically.

1.6 Potential Complications

Implantation of a VAD is an invasive procedure requiring general anesthesia and entry into the thoracic cavity. These surgical procedures are associated with numerous risks. Risks associated with the implant procedure and use of the device may include, but are not limited to, the following¹:

- Death
- Arterial Non-CNS Thromboembolism
 - Air Embolism
- Bleeding
 - Bleeding, perioperative or late
 - GI bleeding / AV malformations
- Burn
- Cardiac Arrhythmias
- Device Malfunction
 - Device Thrombus
 - Electrostatic Discharge (ESD) damage to device
- Hemolysis
- Hepatic Dysfunction
- Hypertension
- Major Infection
 - Driveline Infection
 - Internal Pump Component, Inflow or Outflow Tract Infection
 - Local Infection
 - Sepsis
- Myocardial Infarction
- Neurological Dysfunction
 - Transient Ischemic Attack (TIA)
 - Stroke
 - Ischemic Cerebral Accident (ICVA)
 - Hemorrhagic Cerebral Accident (HCVA)
 - Pericardial Effusion/ Tamponade
- Psychiatric Episodes
 - Suicide
- Pneumothorax
- Renal Dysfunction
- Respiratory Dysfunction
- Right Ventricular Failure
- Venous Thromboembolism
- Wound Dehiscence
- Other
 - Aortic Insufficiency
 - Cardiopulmonary Arrest
 - Multi-organ failure
 - Platelet Dysfunction
 - Pleural Effusion
 - Organ damage during driveline tunneling
 - Pain
 - Syncope
 - Tissue Erosion and other tissue damage
 - Worsening Heart Failure

¹Other than death, the adverse events are listed in alphabetical order according to INTERMACS categories.

1.7 Pivotal US Clinical Study: Bridge-to-Transplant

Pivotal Clinical Study Design

This was a multi-center, prospective, contemporaneous control trial. The trial was non-randomized and open label. Enrollment in the study is complete, subjects have all reached the primary endpoint as described and specified in the protocol, but follow-up of subjects is ongoing.

Subjects were consented for participation and then assessed against the inclusion and exclusion criteria for participation in the study and implantation of the HVAD® Pump. After the surgical recovery period, patients were allowed to leave the hospital if they met additional criteria for hospital discharge. Each patient was followed to 180 days, death, device explant for recovery, or cardiac transplantation, whichever occurred first.

Patient outcomes were compared to a contemporaneously treated cohort of patients as recorded in the Interagency Registry for Mechanical Assisted Circulatory Support (INTERMACS). All patients enrolled in the INTERMACS registry over the same enrollment period as the trial that met the control group inclusion and exclusion criteria comprised the control group.

Study Objectives

Primary Objective

The purpose of the HeartWare™ HVAD™ System study was to evaluate the safety and effectiveness of the HeartWare™ HVAD™ System in patients listed for cardiac transplantation with refractory, advanced heart failure at risk of death. The primary endpoint is success at 180 days which was defined as alive on the originally implanted device or transplanted or explanted for recovery. If explanted for recovery patients must have survived 60 days post-explant to be considered successful.

Effectiveness was measured by the primary endpoint. The proportion of study patients alive, transplanted, or explanted for recovery at 180 days was compared to the same proportion obtained from the INTERMACS registry cohort and tested for non-inferiority.

Secondary Objectives including Safety

Secondary endpoints included: overall survival; incidence of all serious adverse events, including neurocognitive status and unanticipated adverse device effects; incidence of all device failures and device malfunctions; Quality of Life improvement, as measured by the Kansas City Cardiomyopathy Questionnaire (KCCQ) and European Quality of Life Assessment (EuroQol) EQ-5D; and functional status improvement, as measured by New York Heart Association (NYHA) classification and 6-minute walk.

Safety measures included the frequency and rates of adverse events, overall and for each specific event, which were collected throughout HeartWare™ HVAD™ System support.

Study Population Demographics and Baseline Parameters

There were three analysis populations defined for this trial. These are the intent-to-treat population, (ITT), the Safety population (SAF) and the Per Protocol population (PP).

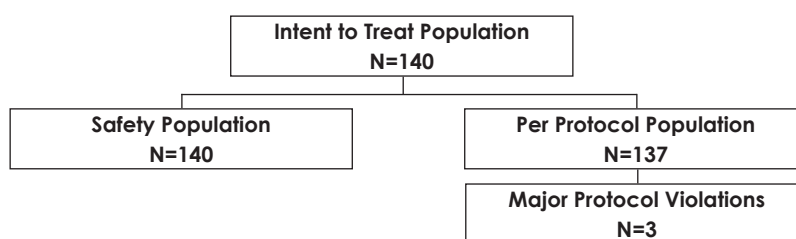

1.7 Pivotal US Clinical Study: Bridge-to-Transplant (continued)

Subjects were predominately male (72.1%) and 53.3 ± 10.3 years of age. BSA and BMI were 2.1 ± 0.3 m² and 28.6 ± 6.1 kg/m² respectively. The principal etiology of heart failure was ischemic heart disease (41%) and the average LVEF was 17.8 ± 7.1 %. Pulmonary Capillary Wedge Pressure (PCWP) was elevated at 23 ± 9 mm Hg and pulmonary artery pressures were also high: $(49 \pm 15)/(25 \pm 9)$ mmHg. The majority of patients were classified as NYHA IV (95%). Laboratory values at baseline were, in general, unremarkable except for an elevated BUN (26 ± 14 mg/dL) and a depressed hematocrit (34 ± 5.8 %).

Eighty percent of subjects in the HeartWare™ HVAD™ System treatment group were on inotropic therapy at baseline. Some (23%) were on more than one inotrope. IABP therapy at baseline was reported for 25% of subjects and 85% presented with an AICD. Subjects received typical medications for congestive heart failure with diuretics (82%) most common.

Comparison of Selected Baseline Characteristics between Treatment and Control Groups

The mean age of implant recipients in the HeartWare™ HVAD™ System group was 53.3 (range 22-70) and for the control, 52.2. Other parameters available to compare included gender, BSA, BUN, right atrial pressure and creatinine. In all cases, the values for both the HVAD treatment and control groups were not statistically significantly different (**Table 1**).

Table 1: Select Baseline Characteristics for HVAD and INTERMACS Groups

Characteristics	HeartWare™ HVAD™ System N=140	INTERMACS N=499	p-value
Age (years)	53.3 ± 10.3	52.2 ± 12.2	0.19
Female Gender, n (%)	39 (28%)	120 (24%)	0.36
BSA (m ²)	2.06 ± 0.28	2.07 ± 0.30	0.59
BUN (mg/deciliter)	25.3 ± 13.5	28.9 ± 20.9	0.94
Right atrial pressure (mmHg)	10.8 ± 3.3	11.5 ± 5.0	0.53
Serum creatinine (mg/dL)	1.3 ± 0.4	1.4 ± 0.6	0.89

Effectiveness Results

Primary Endpoint

The analysis of the primary endpoint demonstrated HVAD non-inferiority to the control group (**Table 2**). The difference in success rates between the HVAD group and controls was less than the 15% non-inferiority margin ($p < 0.0001$). The 95% one-sided UCL on the difference in success rates was 4.5% for the Safety (SAF) population analysis and 0.9% for the Per Protocol (PP) population analysis. The pre-specified primary endpoint was achieved.

1.7 Pivotal US Clinical Study: Bridge-to-Transplant (continued)

Table 2: Success Rates and Inference on Non-Inferiority

	Implanted (N)	Successes N (%)	UCL (%)	p-value
Safety Cohort				
HVAD®	140	127 (90.7)	4.5	<0.0001
Controls	497	448 (90.1)		
Per Protocol Cohort				
HVAD®	137	126 (92.0)	0.9	<0.0001
Controls	497	448 (90.1)		

P-value: From significance test of non-inferiority

UCL: 95% one-sided upper confidence limit on the difference in success rates

Note: The table accounts for 497 of the 499 INTERMACS patients; the remaining 2 patients, who withdrew consent before 180 days, have a missing success/failure outcome.

Competing Outcomes

A competing risks analysis was performed (**Figure 2**), estimating the time-related probability of experiencing each of the component events. These data are calculated from all events occurring during the study duration, including deaths, transplants and exchanges occurring after 180 days but ending with last-patient, last-visit.

Figure 2: Competing Risk Outcomes (HVAD Safety Population)

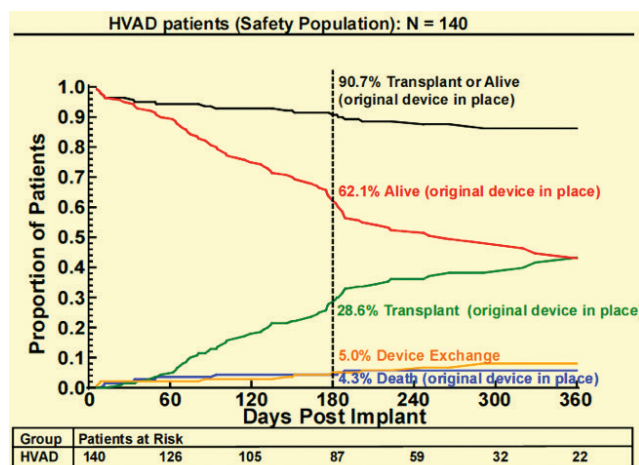

Deaths

There were eight subject deaths during the 180-day study period. Six deaths occurred in subjects with their originally implanted device and two deaths occurred after device exchange.

Safety Results

This study was not randomized and used a contemporaneous control for the sole purpose of comparing a pre-defined success outcome. The adverse events reported here are unique to the HeartWare™ HVAD™ System and have no randomized comparator arm.

1.7 Pivotal US Clinical Study: Bridge-to-Transplant (continued)

Exposure

The total support (exposure) on the original HeartWare™ HVAD™ System was 20,698 days or 56.7 patient-years. The mean duration on device for the 140 subjects was 147.8 days (standard deviation 52.8) with a median 180 (range 6 – 180 days). The mean duration on study was 222.5 days (standard deviation 119) with a median of 196 (range 11 – 588 days). Duration on study exceeds duration on device, because the follow-up post-transplant is included.

Adverse Events

A total of 776 events (**Table 3**) were reported by investigators during the 180 day period on the original device. Of these 437 (437/776, 56.3%) were INTERMACS defined specific events, and 338/776 (43.6%) events were recorded under the INTERMACS category of “Other.” One UADE was reported during the 180-day primary endpoint period.

Table 3: Summary of All Investigator-Reported Adverse Events

Event	Total	%
INTERMACS defined Events	437	56.3%
INTERMACS “Other” AE's	338	43.6%
UADE	1	0.1%
Total	776	100%

INTERMACS Events

The INTERMACS defined adverse events for the 180-day primary endpoint on original device are summarized below and are separated into the perioperative (0-30 days) and post-perioperative (31-180 days) periods. Events meeting INTERMACS criteria are shown in **Table 4**. Bleeding, infections and arrhythmia were the most common. Most bleeding events qualified due to transfusions (see definition below). On the other hand, all reoperations due to bleeding were in the first 30-days post-op (23 vs. 0 events post-30 days).

1.7 Pivotal US Clinical Study: Bridge-to-Transplant (continued)

Table 4: INTERMACS Events by Type and Time of Onset (HeartWare™ HVAD™ System N=140)

INTERMACS defined AEs	Day of Event Onset			
	0-30 Days		31-180 Days	
	Events N	Subjects N (%)	Events N	Subjects N (%)
Bleeding				
Re Op ¹	23	20 (14.3)	0	0
Transfusion Criteria ² >4 Units within 7 Days	10	10 (7.1)	0	0
Any Units at ≥ 7 Days	31	25 (17.9)	46	20 (14.3)
Infections				
Local (Non-device)	20	20 (14.3)	17	17 (12.1)
Driveline Exit	5	5 (3.6)	14	11 (7.9)
Sepsis	3	3 (2.1)	8	7 (5.0)
Neurological Events				
Ischemic CVA	7	7 (5.0)	3	3 (2.1)
Hemorrhagic CVA	2	2 (1.4)	2	2 (1.4)
TIA	2	2 (1.4)	5	4 (2.9)
Respiratory Dysfunction				
26	22 (15.7)	8	5 (3.6)	
Arrhythmia				
Ventricular	15	14 (10.0)	14	11 (7.9)
Supraventricular	25	21 (15.0)	7	6 (4.3)
Right Heart Failure				
Inotropes	17	17 (12.1)	8	7 (5.0)
RVAD	3	3 (2.1)	1	1 (0.7)
Arterial Thromboembolism				
0	0	2	2 (1.4)	
Venous Thromboembolism				
4	4 (2.9)	3	3 (2.1)	
Renal Dysfunction				
8	8 (5.7)	6	5 (3.6)	
Psychiatric Event				
5	5 (3.6)	4	4 (2.9)	
Myocardial Infarction Event				
0	0	1	1 (0.7)	
Hypertension				
1	1 (0.7)	0	0	
Hepatic Dysfunction				
3	3 (2.1)	1	1 (0.7)	
Hemolysis Event³				
1	1 (0.7)	1	1 (0.7)	

¹4 procedures were not included: elective hysterectomy, elective repair of hemorrhoids, HVAD® exchange and RVAD placement.

²Transfusion criteria include: ≥ 20cc/kg packed red blood cells (PRBC) within any 24 hour period during the first 7 day post implant and any transfusion of packed red blood cells (PRBC) after 7 days following implant with the Investigator recording the number of units given.

³Two cases were excluded: 1 case hemolysis < 72 hours post-implant; 1 case hemolysis occurring in the presence of tPA/Integrillin for VAD thrombosis.

1.7 Pivotal US Clinical Study: Bridge-to-Transplant (continued)

The majority of infections did not involve the driveline or cause sepsis. The local, non-device category encompasses a host of sites, including the urinary tract, lungs, sinuses, IV punctures, colon and skin. Infections involving the driveline exit site were more common after hospital discharge (> 30 days). Similarly, subjects were somewhat more likely to experience sepsis from 31-180 days (5.0% of subjects) than perioperatively (2.1%). Nearly a third (11/32) of the supraventricular arrhythmias were bouts of atrial fibrillation, requiring drug therapy. Nearly all the ventricular arrhythmias were ventricular tachycardia. AICD shocks were recorded in 24/29 episodes of ventricular arrhythmia and 2/29 received external cardioversion. Nearly all patients with a reported episode of ventricular tachycardia were subsequently placed on amiodarone.

Respiratory problems were more common in the perioperative period, declining from 26/34 events at 0-30 days to about one-third that number (8/34) from 31-180 days. Subjects were more likely to experience right heart failure events in the perioperative period (20/29). The most common treatment for right heart failure was the use of inotropic drugs and the pulmonary vascular dilator, nitric oxide (25/29). Three subjects required an RVAD and a fourth was exchanged for a pneumatic biVAD at 75 days post-implant. Ischemic strokes (ICVA) were more common overall (10/14 events) and occurred with greater frequency in the perioperative period (7/9 perioperative strokes). Four hemorrhagic strokes (HCVA) were recorded. Three of these resulted in deaths. TIAs were more common in the 31-180 day period (5/7 TIA events). While HCVAs were generally fatal (75%) they were most often associated with hypertension (MAP > 90 mm Hg). Three of the 4 HCVAs had a mean arterial pressure of ≥ 95 mm Hg at the time of the stroke and the one normotensive patient was septic and had an INR of 2.7 (high normal range).

Overall 70% of the patients who experienced ICVAs were transplanted or remained eligible. It is noteworthy that 6/10 ICVA events occurred within 48 hours of implant and may have been related to surgical procedural factors, such as ragged coring of the myocardium for inflow insertion or incomplete device de-airing. These issues were addressed by improvements to the coring tool and by site retraining. The overall stroke survival for the combined ICVAs and HCVAs on the original device was 77% (10/13 patients).

Venous thrombosis occurred in 5% of subjects. Most of these were cases of DVT in the lower extremities. In the arterial thromboembolism category, a case of VAD thrombosis was treated with tPA and resolved and in another case a clot was removed from the left main coronary artery following cardiac catheterization. A third case appeared to involve a shower of small emboli to the periphery.

No subject required permanent dialysis. Psychiatric events were recorded for nine subjects (6.4%). All recovered without sequelae. Two hemolysis events were detected by strict INTERMACS criteria in the absence of VAD thrombosis. These resolved spontaneously.

One subject experienced a myocardial infarction and one subject had a hypertensive event during the perioperative period. Hepatic dysfunction was noted in four subjects.

Adverse events were generally more common in the perioperative period.

Serious Adverse Events

A total of 452 serious adverse events on the original device occurred in 118 (84.3%) subjects (**Table 5**). A total of 287 INTERMACS defined events met the definition of an SAE, and 164 INTERMACS "other" events met the definition of an SAE.

1.7 Pivotal US Clinical Study: Bridge-to-Transplant (continued)

Table 5: Summary of Serious Adverse Events (HeartWare™ HVAD™ System N=140)

Serious Adverse Events (SAEs)	Number of SAEs	Subjects N (%)
Total Serious Adverse Events	452	118 (84.3)
INTERMACS	287	98 (70.0)
“Other”	164	75 (53.6)
UADE	1	1 (0.7)

Device Exchange

Device exchange occurred in 7 patients (7/140, 5.0%) in the SAF population during the period 180 days post-implant. Of these 7 exchanges, 3 were resultant from retained tissue being pulled into the pump from the ventricle in the very early post-operative period and were deemed to be procedure related, 2 were exchanged due to thrombus inside the pump, one was exchanged for a high power event of unknown cause and one due to latent right heart failure which caused the patient to require a biventricular support system.

Device Malfunctions

A device malfunction is defined as a failure of one or more of the components of the HeartWare™ HVAD™ System, which either directly causes or could potentially, cause or induce a state of inadequate circulatory support (low cardiac output state) or death. There was information on 26 malfunctions from 20 subjects entered into the clinical database during the study period (Table 6).

Table 6: Malfunctions by Suspected Component

HeartWare™ HVAD™ System N=140 Device Component ID	Events N (%)
Pump	7 (5.0) *
Controller	7 (5.0)
Battery	1 (0.7)
Battery Charger	0
Monitor	0
Driveline	2 (1.4)
Controller AC Adapter	6 (4.3)
Other Component	3 (2.1)

*Described in Pump Exchange section

1.7 Pivotal US Clinical Study: Bridge-to-Transplant (continued)

Quality of Life: KCCQ And EuroQol

Kansas City Cardiomyopathy Questionnaire (KCCQ): At baseline, 128/140 (91.4%) patients were able to complete the KCCQ and at month 6 there were 88 patients available to complete the test (39 had received a transplant, six had died, seven had met an endpoint receiving a device exchange) (**Table 7**). Of the 88 patients available for assessment, 74 patients had data at month 6. Reasons for missing the month 6 data included: 9 of 14 with poor compliance/missed visit (8 of 9 of these from a single site and 1 of 9 had a prior ICVA with mRS score of 2), 2 were too sick, 1 had no form available, 1 had been transplanted within the 14 day visit window, and 1 had refused. Seventy patients (70) had both baseline and month 6 data. For these 70 patients who were on HVAD® therapy continuously for 180 days had a 31 point improvement in KCCQ Overall Summary Score, over the 180 day period.

Table 7: KCCQ - Overall Summary Score

KCCQ	Baseline	Month 6	Change from Baseline
N	128	74	70
Mean (SD)	34.9 (18.9)	67.5 (20.4)	30.9 (26.5)
Median	31.5	71.4	34.5
Min, Max	0.0, 84.1	19.3, 100.0	-49.4, 80.5
95% CI	31.6, 38.2	62.8, 72.2	24.6, 37.3

European Quality of Life (EuroQol): At baseline, 130/140 (92.9%) of patients were able to complete the test, and at month 6 there were 88 patients available to complete the test, (39 had received a transplant, six had died, seven had met an endpoint receiving a device exchange) (**Table 8**). Of the 88 patients available 75 had data at month 6. Reasons for missing the month 6 data included: 9 of 13 with poor compliance/missed visit (8 of 9 of these from a single site and 1 of 9 had a prior ICVA with mRS score of 2), 2 were too sick, 1 had been transplanted within the 14 day visit window, and 1 had refused. Seventy-two patients (72) had both baseline and month 6 data showing an improvement of 30 points over the 180 day period.

Table 8: EuroQol (EQ-5D) - Summary of Quality of Life

EuroQol	Baseline	Month 6	Change from Baseline
Overall Summary Score			
N	130	75	72
Mean (SD)	39.7 (23.5)	69.8 (19.8)	29.5 (25.2)
Median	40.0	75.0	30.0
Min, Max	0.0, 92.0	4.0, 100.0	-36.0, 80.0
95% CI	35.6, 43.7	65.2, 74.4	23.6, 35.4

Functional Analyses: 6 Minute Walk

6 Minute Walk: Of the 132 patients assessed for the 6-minute walk test, the mean distance walked was 89.4 meters. Seventy-Five (75) of the 88 patients on pump at month 6 completed the test (**Table 9 and Figure 3**). Reasons for missing the 6 minute walk test at month 6 included: 9 of 14 with poor compliance/missed visit (8 of 9 of these from a single site and 1 of 9 had a prior ICVA with mRS score of 2), 2 were too sick, 1 had no form available, 1 had been transplanted within the 14 day visit window, and 1 had refused. These 75 patients showed a mean distance walked of 246 meters, a mean change of 150 meters from baseline.

1.7 Pivotal US Clinical Study: Bridge-to-Transplant (continued)

Table 9: Functional Status – 6 Minute Walk

6 Minute Walk	Baseline	Month 6	Change from Baseline
Distance Walked in Meters			
N	132	75	74
Mean (SD)	89.4 (141.3)	246.0 (203.9)	150.1 (214.1)
Median	0.0	274.0	108.3
Min, Max	0.0, 600.2	0.0, 991.8	-273.1, 700.9
95% CI	65.1, 113.7	199.1, 292.9	100.5, 199.8

Figure 3:
6 Minute Walk Test

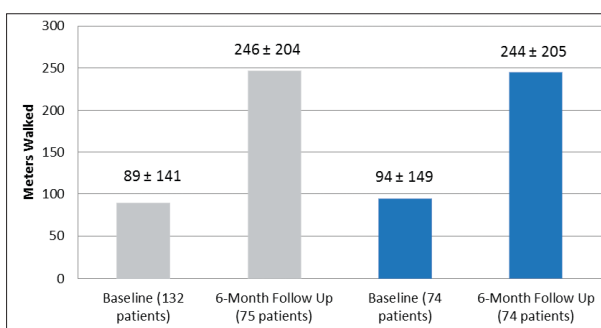

Table 10 shows a breakdown of results of patients who walked at both baseline and at 6 months as well as those patients that did not walk at baseline but did walk at 6 months.

Table 10: 6 Minute Walk – Breakdown of Patients Walking vs. Not Walking at Baseline

HeartWare™ HVAD™ System Patients	Baseline (m)	Month 6 (m)
Patients walking at baseline and at 6 months	260 ± 140 (n=25)	338 ± 202 (n=25)
Patients NOT walking at baseline (for any reason) but walking at 6 months	N/A	333 ± 125 (n=30)

Overall Conclusions from Clinical Data

The HeartWare™ HVAD™ System bridge-to-transplant study (ADVANCE) was a multi-center, prospective, contemporaneous control trial. The purpose of this study was to evaluate the safety and effectiveness in patients listed for cardiac transplantation with refractory, advanced heart failure at risk of death. The primary endpoint was success at 180 days which is defined as alive on the originally implanted HVAD® Pump or transplanted or explanted for recovery.

The analysis of the primary endpoint yielded non-inferiority of the HeartWare™ HVAD™ System to the INTERMACS control. The 95% one-sided UCL on the difference in success rates was 4.5% for the Safety Group and 0.9% for the Per Protocol Group. Each of these limits was less than the 15% non-inferiority margin (p-value <0.0001).

- The pre-specified primary endpoint was achieved.
- Both quality of life and functional capacity showed improvements following implant of the HVAD® Pump.
- The HeartWare™ HVAD™ System has an adverse event profile that supports its safe use for bridge to transplant patients.

1.8 US Clinical Study: Destination Therapy

A. Study Design

Patients in the ENDURANCE trial were enrolled between August 4, 2010 and May 8, 2012. The database for this Panel Track Supplement reflected data collected through June 06, 2016, as well as some additional updated data from March 27, 2017, and included 451 subjects enrolled at 48 investigational sites.

The trial was a prospective, randomized, controlled, multicenter clinical trial. Subjects were randomly assigned using a permuted block, central randomization scheme, in a 2:1 ratio, to receive either the study (HVAD) or control (HeartMate II) device.

The objective of the trial was to compare the safety and effectiveness of HVAD for destination therapy to the HeartMate II, which is legally marketed in the U.S. for destination therapy, in patients with end-stage heart failure who are ineligible for heart transplantation.

The sample size for formal hypothesis testing was to be determined adaptively. Subjects were to be randomized until 450 subjects were randomized and implanted.

It was pre-specified that after the first 300 randomized subjects reached the two-year primary endpoint, the success rate from the control subjects would be assessed. If the observed control success rate was at least 55%, then the data from the first 300 subjects would be analyzed. If the observed control success was less than 55%, then no interim analysis would be performed and the full 450 subjects would be subsequently analyzed. This adaptive sample size for statistical analysis provides at least 90% power to establish non-inferiority.

The ENDURANCE trial was conducted under the oversight of an independent Clinical Events Committee, which adjudicated all the adverse events according to the Interagency Registry of Mechanically Assisted Circulatory Support (INTERMACS) definitions; and an independent Data Safety Monitoring Board reviewed study compliance and monitored adverse events and outcomes.

1. Clinical Inclusion and Exclusion Criteria

Enrollment in the ENDURANCE trial was limited to patients who met the following inclusion criteria:

- Patients ≥ 18 years old with chronic, advanced left ventricular failure with New York Heart Association (NYHA) functional class IIIb or IV limitations despite optimal medical therapy and were transplant ineligible at the time of enrollment in whom informed consent was obtained.

Patients were not permitted to enroll in the ENDURANCE trial if they met any of the following exclusion criteria:

- Patients eligible for cardiac transplant or with prior cardiac transplant.
- Patients with recent (within 14 days) acute myocardial infarction or stroke within 180 days.
- Patients with a mechanical heart valve.
- Patients with severe right heart failure in whom right ventricular support is anticipated.
- Patients who might be unwilling or unable to comply with the study criteria.
- Additional exclusion criteria available in the Clinical Study Report.

1.8 US Clinical Study: Destination Therapy (continued)

2. Follow-up Schedule

All patients were scheduled to return for follow-up examinations at 3, 6, 12, 18, and 24 months with a window of ± 7 days, and at 30, 36, 42, 48, 54, and 60 months with a window of ± 14 days postoperatively.

Preoperative baseline assessments included demographics, medical history, physical examination, concurrent medications, laboratory tests, electrocardiogram (ECG), New York Heart Association (NYHA) classification, The National Institutes of Health (NIH) stroke scale, neurocognitive exam, quality of life, and functional status. Postoperative assessments included LVAD parameters, hemodynamics, concurrent medications, laboratory tests, neurocognitive exam, six-minute walk test, NYHA status, and health status.

3. Clinical Endpoints

The primary endpoint was a composite of two-year survival free of disabling stroke (i.e., modified Rankin score ≥ 4 assessed 24 weeks post-event), while alive on the originally implanted device, electively transplanted or explanted due to left ventricular recovery. Success in meeting the primary endpoint was tested for non-inferiority of the experimental group against the control device. The non-inferiority margin of 15% was based on the observed success rate of the control device at $>55\%$. Estimates of stroke-free survival were performed for each treatment using Kaplan-Meier non-inferiority log-rank methodology, comparing study device to control using a one-sided alpha of 0.05; that is, non-inferiority will be established if the one-sided upper confidence limit on the difference in proportions is less than the non-inferiority margin. Analysis of the primary endpoint was conducted on the Per Protocol (PP) population.

Patients were considered a success if at 730 days post implantation, the subject was alive, did not have a stroke of mRS ≥ 4 assessed 24 weeks post-stroke, and remained on the originally implanted device, unless the device was removed due to heart recovery, or the subject was electively transplanted. Patients were considered a failure if at 730 days post implantation, they expired, had a stroke with a modified Rankin score ≥ 4 assessed 24 weeks post-stroke, or were urgently transplanted or had surgery for LVAD removal or replacement due to failure of the original device.

There were seven (7) secondary endpoints, of which the following three (3) were to be assessed inferentially to test for superiority in a fixed-sequence procedure if non-inferiority was established for the primary endpoint: incidence of bleeding (per INTERMACS definition), incidence of major infections (per INTERMACS definition), and overall survival (time to death). In addition, a number of subgroup analyses were pre-specified, including gender and BSA ($<1.5 \text{ m}^2$ vs. $\geq 1.5 \text{ m}^2$).

1.8 US Clinical Study: Destination Therapy (continued)

B. Accountability of PMA Cohort

Pre-specified Interim Analysis

Per the pre-specified analysis plan, the interim analysis cohort (N=300) was to serve as the principal analysis cohort if the Control group success rate for the primary endpoint was at least 55%; as shown below, the observed success rate for the Control group was 59%. A total of 451 patients (inclusive of the initial 300 patients) were enrolled, of which 445 were implanted with a device. This summary presents the ENDURANCE trial results using both the pre-specified interim analysis and full enrollment cohorts. FDA considered the interim analysis to be the principal analysis of the ENDURANCE trial, but considered all analyses when evaluating the safety and effectiveness of the HVAD. The analyses from the full enrollment cohort are included in the Other Results section.

At the time of database lock for the interim analysis 100% of the pre-specified interim analysis cohort (300 patients) had been followed through the 2-year primary endpoint time point. The disposition of the patients is shown in **Figure 4**.

The Randomized population (HVAD N=200 and Control N=100) included all subjects who were consented (Intent-to-Treat (ITT)) and then enrolled in the study.

The Anesthetized Population (AP) included all randomized subjects who receive induction of anesthesia for implantation.

The Anesthetized and Implanted Population (AIP) population, equivalent to an As Treated population, consisted of all randomized subjects who received induction of anesthesia for implantation and received an implant of an LVAD. In the full cohort (N=445), four (4) patients crossed over from HVAD to Control and three (3) patients crossed over from Control to HVAD after randomization but before receiving a device, and one (1) patient in the Control arm did not receive any device. As such, the AT population for the interim analysis consists of 300 patients, 197 in the HVAD arm and 103 in the Control arm.

The Per Protocol (PP) population included all subjects in the AIP population analyzed according to the LVAD to which they were randomized. This definition is more consistent with the ICH definition of what a modified ITT population would be.

The Inclusion Compliant (IC) population included all randomized subjects who received the LVAD to which they were randomized and who did not violate certain inclusion and exclusion criteria that would likely have an effect on outcome.

The primary analysis was performed on the Per Protocol (PP) population. All safety analyses were performed on the AIP population.

1.8 US Clinical Study: Destination Therapy (continued)

Figure 4: Disposition of First 300 Subjects in the ENDURANCE Trial

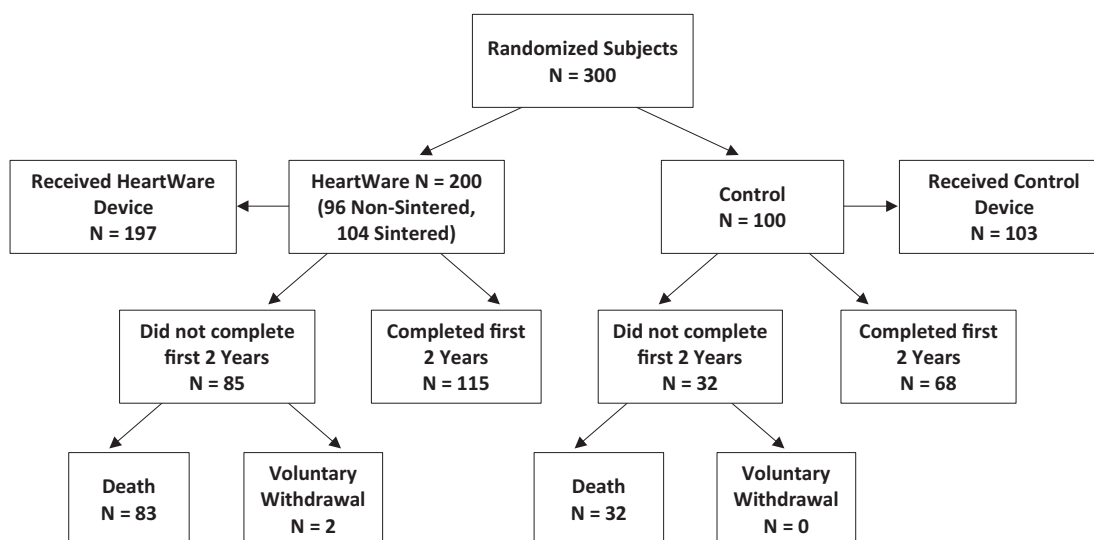

C. Study Population Demographics and Baseline Parameters

The demographics and baseline characteristics, as summarized in **Table 11**, are typical for an LVAD study performed in the U.S. The HVAD and Control groups did not differ significantly.

Table 11: Patient Demographics and Baseline Characteristics in the first 300 Subjects in the ENDURANCE Trial

Demographics and Baseline Characteristics	HVAD (N=200)	Control (N=100)	P-value
Age (years)	64.4 ± 12.0	66.1 ± 10.4	0.25
Male gender (%)	77.5%	80.8%	0.66
Race (%)			0.37
White	79.5%	75.0%	
Black or African American	19.5%	25.0%	
Other	1.0%	0.0%	
Height (cm)	173.5 ± 9.8	175.2 ± 9.3	0.15
Body Surface Area (m ²)	2.0 ± 0.3	2.0 ± 0.3	0.98
INTERMACS Profile (%)			0.17
1	3.5%	1.0%	
2	27.5%	38.0%	
3	39.5%	41.0%	
4	21.5%	13.0%	
5-7	8.0%	7.0%	
Ischemic Etiology of Heart Failure	59.5%	59.0%	> 0.99

1.8 US Clinical Study: Destination Therapy (continued)

D. Safety and Effectiveness Results

1. Primary Endpoint

The pre-specified interim analysis was conducted on the first 300 patients to reach two (2) years post implantation. The Kaplan-Meier estimate for stroke-free success at 2 years for the Control arm was 59.0%; as such, the interim analysis represented the primary analysis for the ENDURANCE trial. The Kaplan-Meier estimate for stroke-free success at 2 years for the HVAD arm was 51.1%. The results of the interim analysis are shown in **Figure 5**. The upper bound of the confidence interval around the difference exceeded the 15% non-inferiority margin (17.9%), resulting in a p-value of 0.1219. The interim analysis showed that the trial failed to demonstrate non-inferiority of the HVAD to the Control.

Figure 5: ENDURANCE Trial Primary Endpoint. Survival at 2 years free from disabling stroke (mRS ≥ 4) and alive on the originally implanted device, or transplanted or explanted for recovery.

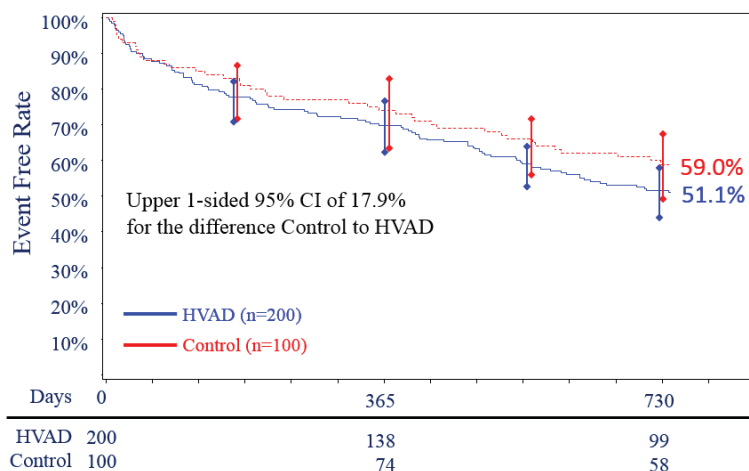

A binary analysis from the pre-specified interim analysis is presented in **Table 12**.

1.8 US Clinical Study: Destination Therapy (continued)

Table 12: Binary Analysis of the Primary ENDURANCE Endpoint and its Components for Subjects Receiving Study or Control Device

Event Free Survival at 2 years	HVAD (N=200)	Control (N=100)
Success	51.5% (103)	59 (59.0%)
Failure	48.5% (97)	41.0% (41)
If Failure, reason:		
Patient dies	35.5% (71)	25.0% (25)
Device malfunction or failure requiring exchange, explant or urgent transplant	11.0% (22)	16.0% (16)
Exchange	9.5% (19)	14.0% (14)
Explant	0.0% (0)	0.0% (0)
Urgent Transplant	1.5% (3)	2.0% (2)
Disabling stroke (mRS \geq 4 at 24 weeks)	1.5% (3)	0.0% (0)
Imputed failure*	0.5% (1)	0.0% (0)

A subject may have multiple reasons for not completing the first two (2) years, only the first failure type for each subject is specified.

*Patient experienced a stroke prior to their 2-year endpoint, and died beyond the 2 year endpoint, but before the 24 week mRS assessment.

2. Secondary Endpoints

Because the primary endpoint was not met per the pre-specified interim analysis, the hypotheses associated with the secondary endpoints of incidence of bleeding (per INTERMACS definition), incidence of major infections (per INTERMACS definition), and overall survival (time to death) could not be tested. As such, the secondary endpoints were not reported.

3. Other Results - Adjunctive analysis: Primary Endpoint Using Expanded Dataset

Following the interim analysis at 300 patients, the trial was expanded to enroll additional patients to further investigate various device, procedural, and clinical changes introduced during the trial. A total of 451 patients (inclusive of the initial 300 patients) were enrolled, of which 445 were implanted with a device. The patient disposition is summarized in **Figure 6**. The results of the expanded dataset are summarized below.

1.8 US Clinical Study: Destination Therapy (continued)

Figure 6: Disposition of Subjects in the ENDURANCE Expanded Dataset

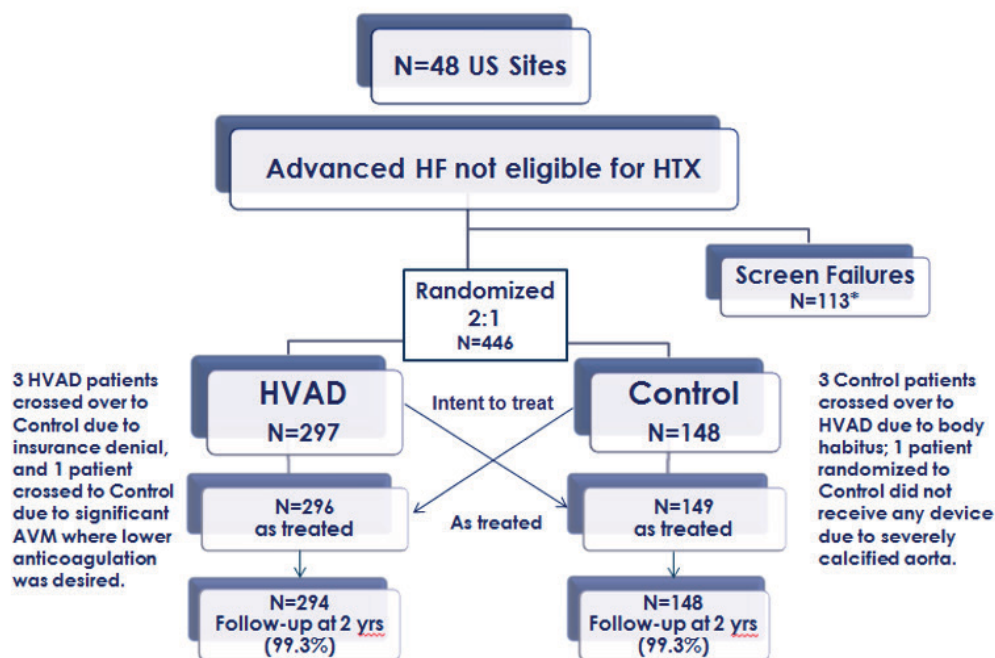

The demographics and baseline characteristics of the ENDURANCE expanded dataset is summarized in **Table 13**. The demographics and baseline characteristics are typical for an LVAD study performed in the U.S. The HVAD and Control groups did not differ significantly with respect to severity of illness, baseline hemodynamic characteristics, or treatment with evidence-based therapy for heart failure at the time of enrollment. However, subjects in the control group were slightly older (66.2 versus 63.9, control versus HVAD, $P=0.04$).

1.8 US Clinical Study: Destination Therapy (continued)

Table 13: Patient Demographics and Baseline Characteristics of the ENDURANCE Expanded Dataset

Demographics and Baseline Characteristics	HVAD (N=297)	Control (N=148)	P-value
Age (years)	63.9 ± 11.6	66.2 ± 10.2	0.044
Male gender (%)	76.4%	82.4%	0.178
Race (%)			0.962
White	76.8%	77.7%	
Black or African American	22.2%	21.6%	
Other	1.0%	0.7%	
Height (cm)	173.8 ± 9.4	175.5 ± 9.1	0.068
Body Surface Area (m ²)	2.0 ± 0.3	2.0 ± 0.3	0.615
INTERMACS Profile (%)			0.989
1	3.4%	3.4%	
2	29.0%	31.1%	
3	40.4%	40.5%	
4	19.9%	18.2%	
5-7	7.4%	6.8%	
Ischemic Etiology of Heart Failure	57.9%	60.1%	0.684
Smoker	68.0%	62.2%	0.243
Diabetic	44.4%	43.9%	> 0.999
Previous Stroke/TIA	19.2%	16.2%	0.515
Hypertension requiring medication	65.3%	70.9%	0.241
Serum creatinine (mg/dL)	1.5 ± 0.5	1.4 ± 0.5	0.760
Severe tricuspid valve insufficiency	12.0% (N=292)	5.5% (N=146)	0.040
Left ventricular ejection fraction (LVEF, %)	17.1 ± 4.6	16.2 ± 4.8	0.055

Survival free from disabling stroke (mRS ≥4) and alive on the originally implanted device, or transplanted or explanted for recovery for the complete ENDURANCE population is shown below in **Figure 7**. The expanded dataset includes a higher proportion of HVAD devices having titanium-sintered inflow cannulae, a device modification that was introduced during ENDURANCE and designed to decrease thromboembolic adverse event rates. Post hoc one-year comparisons of all sintered HVADs (pooled from both ENDURANCE and ENDURANCE-Supplemental) to pooled Control subjects were also performed, as shown in **Figure 7**.

1.8 US Clinical Study: Destination Therapy (continued)

Figure 7: ENDURANCE Trial Expanded Dataset: Survival free from disabling stroke (mRS ≥ 4) and alive on the originally implanted device, or transplanted or explanted for recovery in the overall study dataset.

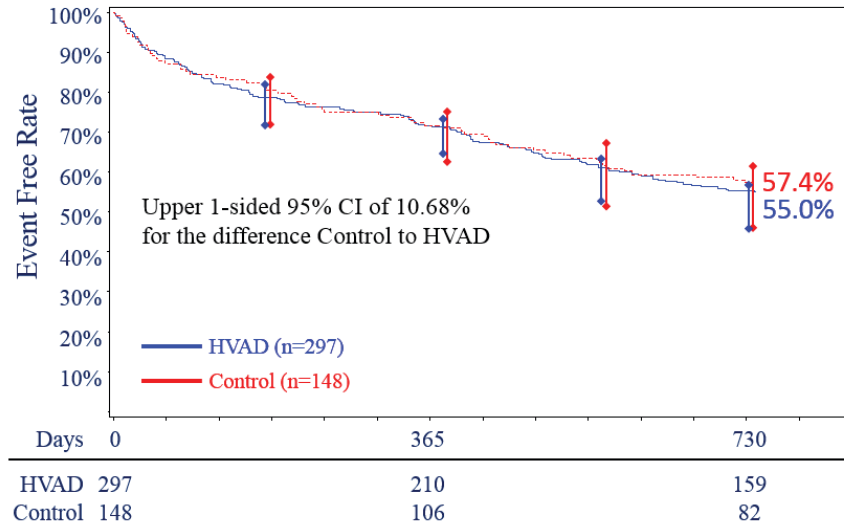

The post hoc comparison of sintered and non-sintered HVAD® Pumps in the interim analysis cohort did not demonstrate markedly different results (See **Figure 8A, 8B**).

Figure 8: Comparison of Outcomes from the Interim analysis of Subjects with Sintered Pumps Compared to Control: Survival free from disabling stroke (mRS ≥ 4) and alive on the originally implanted device, or transplanted or explanted for recovery in A) the subset of subjects receiving a sintered HVAD® Pump, compared to Control, and in B) the subset of subjects receiving the non-sintered HVAD® Pump. This analysis is based on the as-treated population.

A) Sintered:

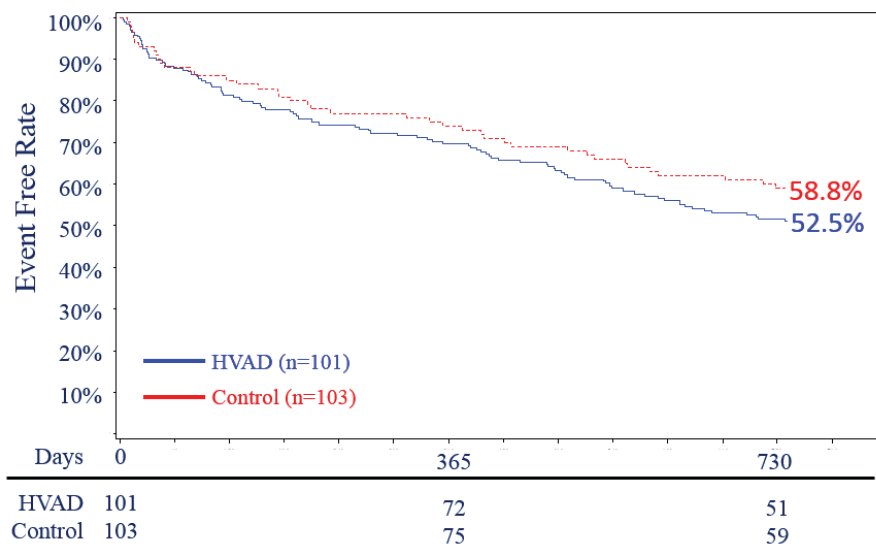

1.8 US Clinical Study: Destination Therapy (continued)

B) Non-Sintered:

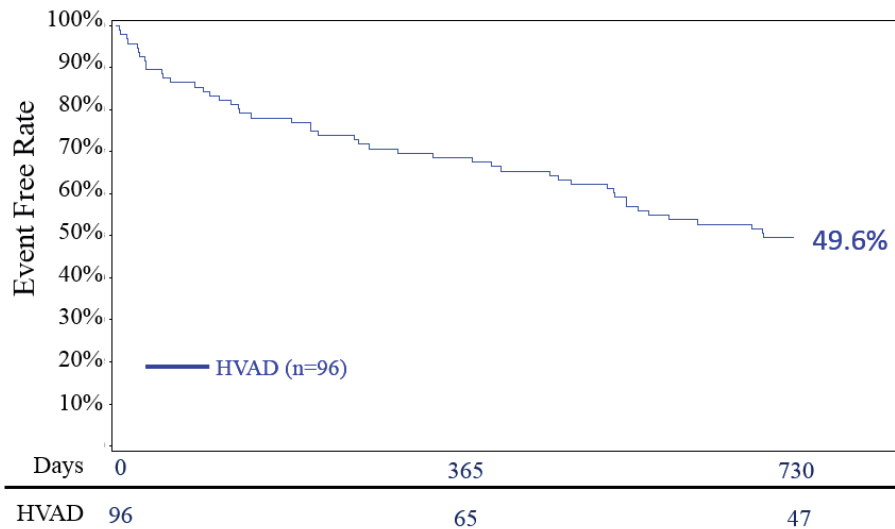

Additional post hoc one-year comparisons of all sintered HVADS (pooled from both ENDURANCE and ENDURANCE-Supplemental) to pooled Control subjects were also performed, and analyzed against the primary endpoint definition of the ENDURANCE Trial (at one year, **Figure 9A**) and against the primary endpoint of the ENDURANCE Supplemental Trial (**Figure 9B**).

Figure 9: An Analysis of Patients Receiving Sintered HVAD® Pumps (Pooled ENDURANCE and ENDURANCE Supplemental) Compared to Control. A) the Primary Endpoint of the ENDURANCE Trial at 1 year, and B) the Primary Endpoint of the ENDURANCE Supplemental Trial.

A) Survival on Original Device Free from Disabling Stroke (mRS ≥4)

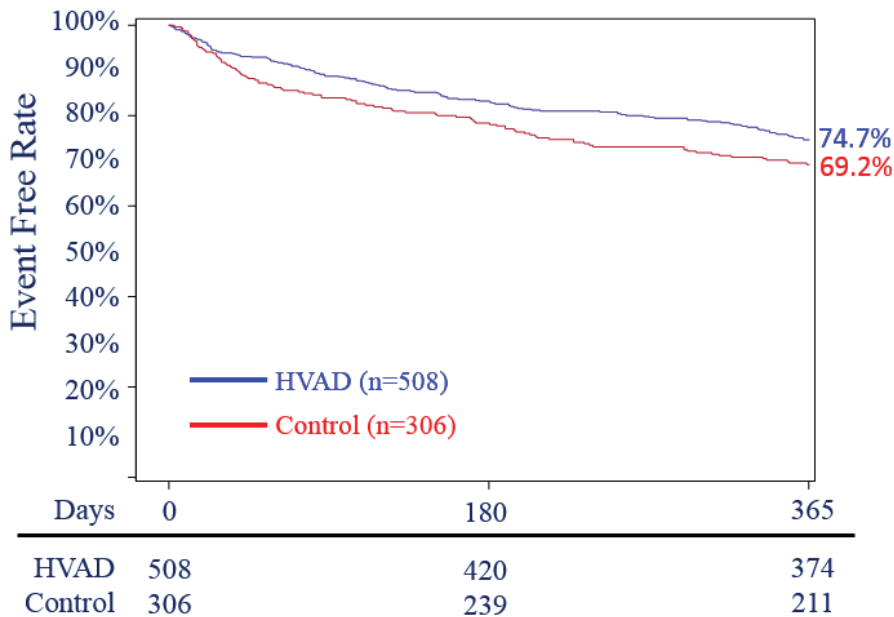

1.8 US Clinical Study: Destination Therapy (continued)

B) Survival on Original Device Free from Neurologic Events (Strokes with mRS>0, TIA or SCI)

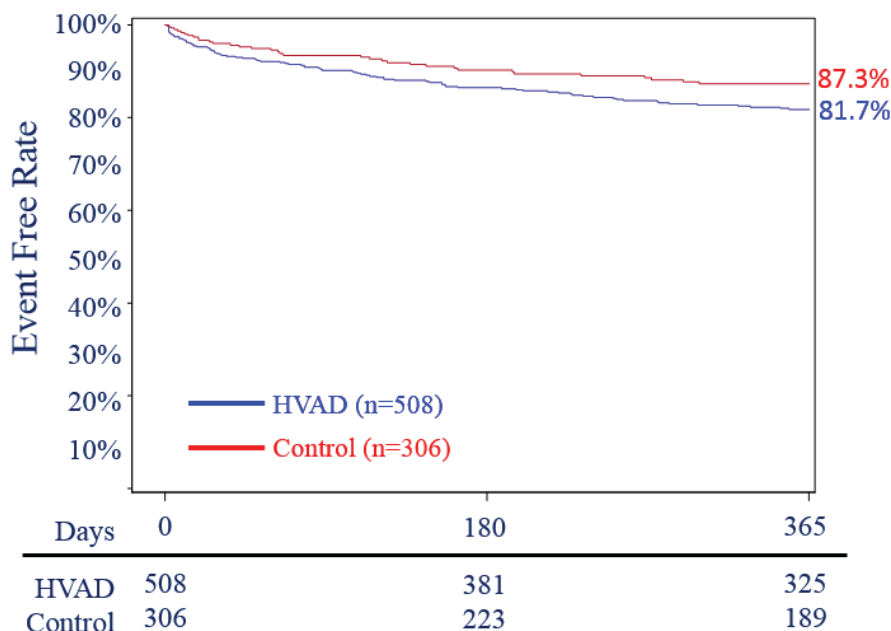

Table 14: Binary Analysis of ENDURANCE Expanded Dataset: Survival at 2 years free from disabling stroke (mRS ≥ 4) and alive on the originally implanted device, or transplanted or explanted for recovery.

Event Free Survival at 2 years	HVAD (N=297)	Control (N=148)
Success	55.2% (164)	57.4% (85)
Failure	44.8% (133)	42.6% (63)
If Failure, reason:		
Patient dies	34.7% (103)	26.4% (39)
Device malfunction or failure requiring exchange, explant or urgent transplant	8.8% (26)	16.2% (24)
Exchange	7.7% (23)	13.5% (20)
Explant	0.0% (0)	0.7% (1)
Urgent Transplant	1.0% (3)	2.0% (3)
Disabling stroke (mRS ≥ 4 at 24 weeks)	1.0% (3)	0
Imputed failure*	0.3% (1)	0

A subject may have multiple reasons for not completing the first two (2) years, only the first failure type for each subject is specified.

*Patient experienced a stroke prior to their 2-year endpoint, and died beyond the 2 year endpoint, but before the 24 week mRS assessment.

1.8 US Clinical Study: Destination Therapy (continued)

In the analyses presented on the entire ENDURANCE trial cohort, the secondary endpoints were analyzed and descriptive data include the following:

- The incidence of bleeding was 60.1% for the HVAD compared to 60.4% for the Control.
- The incidence of major infections was 69.3% for the HVAD and 62.4% for the Control.
- Overall survival was 60.2% for the HVAD and 67.6% for the Control.

The CEC adjudicated causes of death for the entire ENDURANCE trial cohort are shown in **Table 15**.

Table 15: ENDURANCE Expanded Dataset Cause of CEC Adjudicated on Device Death within 730 days (AIP as Received)

Cause of Death	HVAD (N=296)	Control (N=149)
Total	38.5% (114)	30.9% (46)
Bleeding	0.3% (1)	0.7% (1)
Cardiovascular procedure	1.4% (4)	1.3% (2)
Heart failure	16.2% (48)	14.8% (22)
Infection	3.0% (9)	2.7% (4)
Malignancy	1.4% (4)	0.7% (1)
Multisystem organ failure	0.0% (0)	0.7% (1)
Respiratory failure	0.0% (0)	0.7% (1)
Stroke	8.4% (25)	6.0% (9)
Sudden death	3.7% (11)	2.0% (3)
Trauma	0.7% (2)	0.0% (0)
Other cardiovascular	2.7% (8)	1.3% (2)
Other non-cardiovascular	0.7% (2)	0.0% (0)

Overall survival for the ENDURANCE trial expanded dataset beyond the two (2) year timepoint is included below in **Figure 10**. Aggregate 5-year mortality results for all ENDURANCE subjects were similar.

1.8 US Clinical Study: Destination Therapy (continued)

Figure 10: Kaplan Meier Survival (Time to Death) in ENDURANCE through 5 years (PP, Per Protocol).

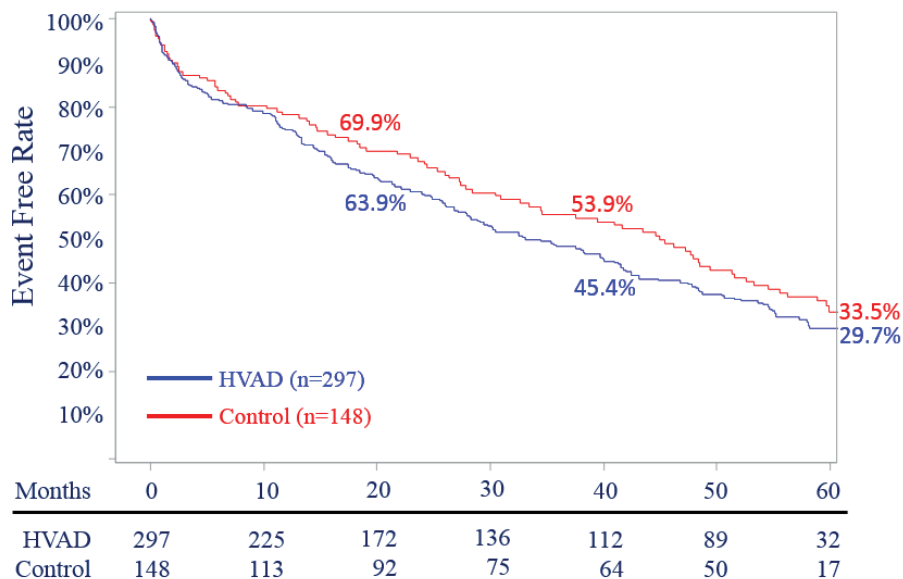

Adverse events

The key safety/adverse event outcomes for the ENDURANCE trial expanded dataset are presented in **Table 16** below. Patients in the HVAD arm had a higher rate of ischemic and hemorrhagic stroke, sepsis, and right heart failure compared to control. An analysis of the patient-level data indicated that elevated blood pressure appeared to be a risk factor for stroke, particularly hemorrhagic stroke.

1.8 US Clinical Study: Destination Therapy (continued)

Table 16: Summary of INTERMACS Adverse Events Occurring Through 2 Years in Subjects in the ENDURANCE Trial Expanded Dataset

Adverse Event	HVAD (N=296)	Control (N=149)
Overall Bleeding events	60.1% (178)	60.4% (90)
GI Bleed	35.1% (104)	34.2% (51)
Cardiac Arrhythmia	37.8% (112)	40.9% (61)
Hepatic Dysfunction	4.7% (14)	8.1% (12)
Hypertension	15.9% (47)	16.8% (25)
Sepsis	23.6% (70)	15.4% (23)
Driveline Exit Site Infection	19.6% (58)	15.4% (23)
Stroke	29.7% (88)	12.1% (18)
Ischemic Cerebrovascular Event	17.6% (52)	8.1% (12)
Hemorrhagic Cerebrovascular Event	14.9% (44)	4.0% (6)
TIA	8.4% (25)	4.7% (7)
Renal Dysfunction	14.9% (44)	12.1% (18)
Respiratory Dysfunction	29.1% (86)	25.5% (38)
Right Heart Failure	38.5% (114)	26.8% (40)
Need for RVAD*	2.7% (8)	3.4% (5)
Pump Replacement	7.8% (23)	13.4% (20)
Exchange for Pump Thrombosis	6.4% (19)	10.7% (16)
Device Malfunction or Failure	31.4% (93)	25.5% (38)

*Site-reported event.

Abbreviations: GI - gastrointestinal; RVAD=right ventricular assist device; TIA= transient ischemic attack (<24 hours).

Note: The event of device thrombosis reported is not an INTERMACS-defined event.

Stroke-related Deaths

Per CEC adjudication, among the full AIP population 12.5% (37/296) of HVAD patients and 6.7% (10/149) of Control patients had stroke-related deaths (data lock date of May 30, 2017, all patients with follow-up > 4 years or censored). HVAD subjects in the ENDURANCE trial had a risk of death from stroke that was 87% greater than the risk of Control patients. The rate of stroke-related death within 2 years of implantation was 8.4% (25/296) for HVAD patients and 6.0% (9/149) for Control patients. The rate of later-onset stroke-related death (i.e., stroke occurring after 2 years of LVAD support) was 3.7% (11/296) for HVAD patients and 0.7% (1/149) for Control patients. The majority of HVADs which were involved with stroke-related deaths had sintered inlet cannulae.

1.8 US Clinical Study: Destination Therapy (continued)

Device Failures and Malfunctions

The incidence of device failures and device malfunctions within 730 days was 31.4% in the HVAD arm vs. 25.5% in the Control arm. The rates of pump thrombosis were similar in both arms, though sintering of the HVAD did appear to decrease this event. Device malfunctions related to controller faults were substantially more frequent in the HVAD arm.

Table 17: Device Failure or Malfunctions in the ENDURANCE Trial Expanded Dataset

Parameter	HVAD Sintered (N=200)	HVAD Non-Sintered (N=96)	Control (N=149)
Based on CEC Adjudication Data			
Device Failure	30.5% (6)	33.3% (32)	25.5% (38)
Type of Device Malfunction			
Controller fault	10.0% (20)	7.3% (7)	2.7% (4)
Critical low battery	0.0% (0)	1.0% (1)	0.7% (1)
Damaged battery	1.0% (2)	0.0% (0)	0.0% (0)
Damaged cable	2.5% (5)	3.1% (3)	4.0% (6)
Damaged controller	2.0% (4)	3.1% (3)	0.0% (0)
Electrical fault	2.0% (4)	0.0% (0)	0.0% (0)
Iatrogenic/Recipient-Induced Failure	0.5% (1)	0.0% (0)	0.7% (1)
Insufficient battery charging	1.5% (3)	1.0% (1)	0.0% (0)
Power disconnect	2.5% (5)	0.0% (0)	1.3% (2)
Pump	0.0% (0)	0.0% (0)	2.7% (4)
Pump Thrombosis	10.0% (20)	22.9% (22)	11.4% (17)
Other	4.5% (9)	1.0% (1)	3.4% (5)

Rehospitalizations

The average number of re-hospitalizations within 730 days after the initial hospitalization was similar between the HVAD arm and the Control arm, as shown in **Figure 11**. For the AIP population, the HVAD subjects were re-hospitalized on average, 4.1 times, compared to 3.6 times in the Control group.

1.8 US Clinical Study: Destination Therapy (continued)

Figure 11: Average Number of Rehospitalizations over Two Years in the ENDURANCE Trial Expanded Dataset

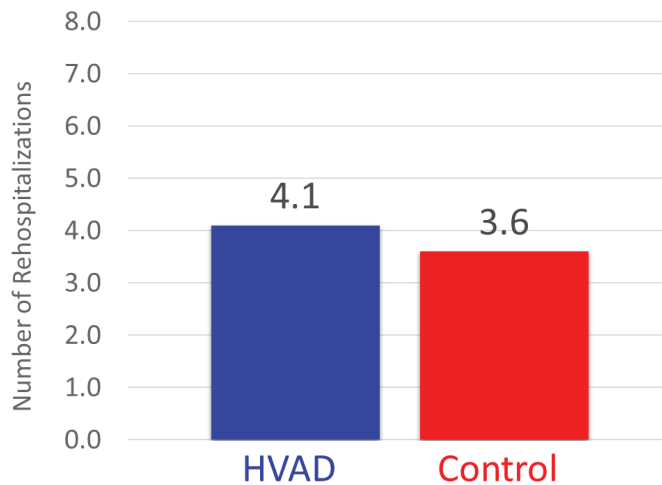

Functional Status

Functional status was assessed by the NYHA class and the 6-minute walk test (6MWT), as shown in **Figures 12 and 13**. Following LVAD implant, approximately 70-80% of subjects in both arms improved to NYHA class I or II by Month 12. The median baseline 6-minute walk distance (6MWD) was 0 meters for both study and control subjects. At 3 months following LVAD implant, 6MWD increased to a median of 210 meters and 201 meters for study and control subjects, respectively. These improvements were sustained through two (2) years.

Figure 12: ENDURANCE Trial Expanded Dataset Six-Minute Walk Test

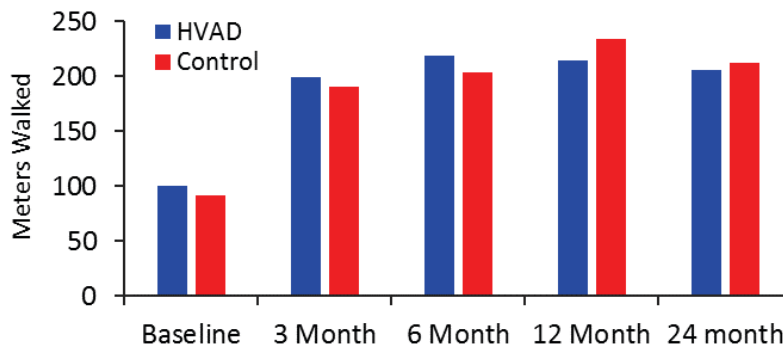

1.8 US Clinical Study: Destination Therapy (continued)

Figure 13: ENDURANCE Trial Expanded Dataset NYHA Classification Improvement

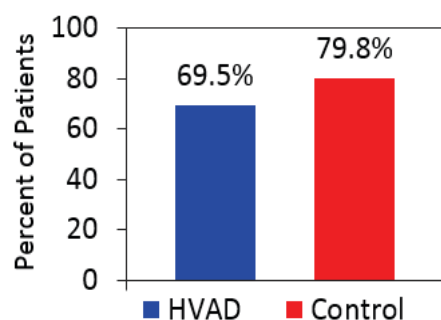

Quality of Life

The quality of life was assessed by the EQ-5D-5L and the KCCQ questionnaires, as summarized in **Figure 14**. At baseline, subjects in both cohorts had poor quality of life and health status assessed by KCCQ and EuroQOL EQ-5D. At 3 months, median KCCQ score had improved by 27.3 points and 24.2 points for study and control subjects, respectively. EuroQOL EQ-5D VAS improved an average of 1.6 points at 3 months for subjects in the study arm and 1.7 points at 3 months for subjects in the control arm. Improvements in KCCQ and EuroQOL EQ-5D were sustained during the follow-up period.

Figure 14: Improvements in Quality of Life and Functional Capacity in the ENDURANCE Trial Expanded Dataset. A) Change over time of the KCCQ Overall Summary Score. B) Change over baseline in the EQ-5D Visual Analog Scale.

A. KCCQ

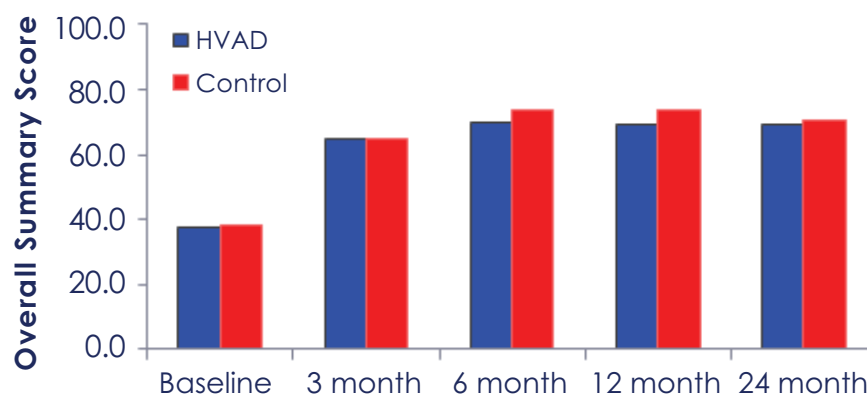

1.8 US Clinical Study: Destination Therapy (continued)

B. EQ-5D

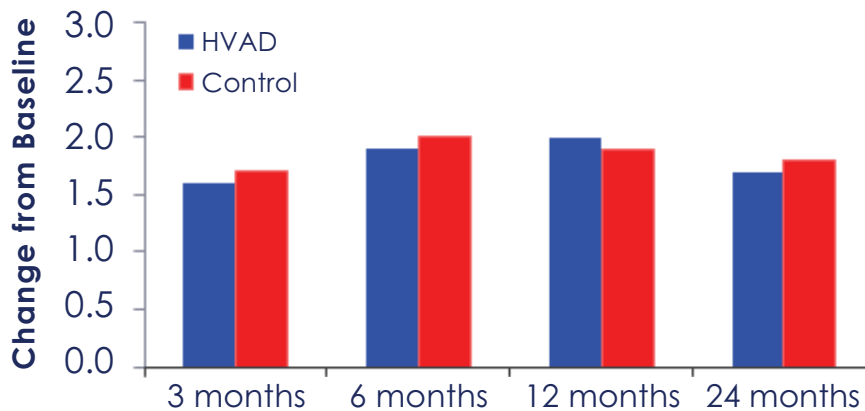

Subgroup Analyses

The following preoperative characteristics were evaluated for potential association with outcomes: gender, and BSA ($< 1.5 \text{ m}^2$, $\geq 1.5 \text{ m}^2$). The pre-specified sub-group analyses showed no major clinical differences in outcomes based on gender or BSA.

Conclusions from the ENDURANCE Destination Therapy Trial

The ENDURANCE trial did not meet its pre-specified primary endpoint, a demonstration of non-inferiority of the HVAD to the control device for patients alive on original device at two (2) years free from disabling stroke ($\text{mRS} \geq 4$). However, an adjunctive analysis using the full-enrollment dataset demonstrated similar endpoint results, with 57.4% success for control and 55% success for HVAD. Following LVAD implant, approximately 80% of subjects in both arms improved to NYHA class I or II symptomatology. At 3 months following LVAD implant, median 6 minute walk distance increased in both arms (210 meters and 201 meters for study and control subjects, respectively). Patients in both arms also showed comparable improvement in quality of life from baseline to 3 months as measured by EQ-5D-5L and KCCQ, and the results were sustained through 2 years.

1.9 Destination Therapy Supplemental Study

A. Study Design

The objective of the ENDURANCE Supplemental trial was to evaluate the safety and effectiveness of a prospective blood pressure management strategy in HVAD DT patients. The purpose of implementing the prospective blood pressure management strategy was to investigate its effect on the stroke rates in HVAD subjects. The trial was a prospective, randomized, controlled, un-blinded, multicenter clinical study. Subjects were randomly assigned using a permuted block, central randomization scheme, in a 2:1 ratio, to receive either the study (HVAD) or control (HeartMate II) device. All HVAD subjects, in addition to receiving standard of care management, were required to adhere to a blood pressure management protocol that aimed to maintain mean arterial pressure (MAP) \leq 85 mmHg (automated pneumatic cuff method) or $<$ 90 mmHg (Doppler cuff method). Control patients were not managed with a blood pressure management protocol.

Patients in the ENDURANCE Supplemental trial were enrolled between October 25, 2013 and August 7, 2015. 475 subjects were randomized, with 465 patients implanted at 47 investigational sites.

Similar to the ENDURANCE trial, the ENDURANCE Supplemental trial was conducted under the oversight of an independent Clinical Events Committee and monitored by an independent Data Safety Monitoring Board.

1. Clinical Inclusion and Exclusion Criteria

Enrollment in the ENDURANCE Supplemental trial was limited to patients who met the same inclusion and exclusion criteria as in the ENDURANCE trial.

2. Follow-up Schedule

All patients were scheduled to return for follow-up examinations at 3 and 6 months with a window of \pm 7 days, at 12 months with a window of + 7 days, and at 18, 24, 30, 36, 42, 48, 54, and 60 months with a window of \pm 14 days postoperatively.

The pre- and post-operative assessments were the same as in the ENDURANCE trial.

3. Clinical Endpoints

The primary endpoint was the incidence of neurologic injury at 12 months. Neurologic injury was defined as an ICVA or HCVA with mRS $>$ 0 at 24 weeks post-stroke, or a TIA, or as a spinal cord infarct (SCI).

The HVAD was to be considered non-inferior to the HeartMate II if the upper bound of the two-sided 90% exact binomial confidence interval of the difference in the primary endpoint between the HVAD arm and the control arm was less than 6%.

There were two secondary endpoints. The first secondary endpoint was incidence of HVAD stroke and TIA by 12 months on the originally implanted HVAD. Unlike the primary endpoint, this secondary endpoint included those strokes that were classified as mRS=0 at 24 weeks post-stroke. This endpoint was to be tested by comparison to a performance goal of 17.7%; the performance goal was equivalent to the lower 95% confidence interval of the one-year stroke/TIA rate among sintered HVAD patients in the ENDURANCE trial.

1.9 Destination Therapy Supplemental Study (continued)

The second secondary effectiveness endpoint was analogous to the ENDURANCE trial's primary endpoint, in that it compared the composite of stroke-free (mRS < 4 at 24 weeks post-stroke) survival while on the original device between HVAD and Control arms; however, the time point for this endpoint was one year, unlike the ENDURANCE trial's 2-year endpoint. This endpoint was to test for non-inferiority of the HVAD to the control device, with a non-inferiority margin of 15%.

Additional endpoints included adverse events, device malfunctions and failures, as well as health status and functional improvements.

B. Accountability of PMA Cohort

At the time of database lock, of the 494 patients enrolled in the ENDURANCE Supplemental trial, 93.7% (463) patients were available for analysis of the primary objective at the completion of the study, the 12-month post-operative visit. The disposition of the patients is shown in **Figure 15**.

Figure 15: Disposition of Subjects in the ENDURANCE Supplemental Trial

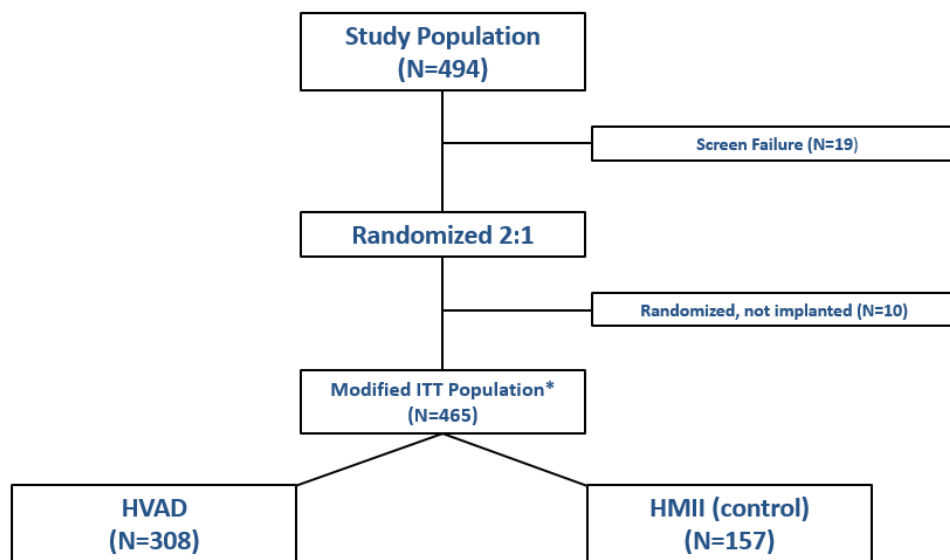

* Modified Intent-to-Treat subjects in which the pump was surgically inserted and turned on. Modified ITT and As-Treated (AT) populations were identical.

1.9 Destination Therapy Supplemental Study (continued)

The Modified Intent-to-Treat Population (mITT; Total N=465; HVAD, N=308 and Control, N=157) included all subjects who received a device. It was analyzed according to the device to which the subjects were randomized.

All safety analyses were performed on the safety population (SAF), which assigned subjects to the device they actually received. The SAF was equivalent to the mITT population.

The Complete Case Population includes all subjects in the mITT population except those who withdraw, are lost to follow-up, or have missing outcomes (any subject with missing post-event mRS) on original device. It differs for each objective. For the primary endpoint, the Complete Case Population was defined as the mITT population excluding any subjects who withdrew or were lost to follow-up, and any subjects who were missing CEC adjudicated mRS scores (both day of event and 24 weeks post-event) for the latest stroke event on original device. For the secondary endpoint of stroke/TIA incidence at 12 months on the originally implanted HVAD, the Complete Case Population was defined as the mITT population excluding the subjects who withdrew or were lost to follow-up. For the secondary endpoint of stroke-free success (mRS <4 at 24 weeks post-stroke) at 12 months, the Complete Case Population was defined as the mITT population excluding subjects who withdrew or were lost to follow-up, and those subjects who were missing a 24 week mRS score for their last stroke on original device (within 1 year post original implant).

C. Study Population Demographics and Baseline Parameters

The demographics and baseline characteristics of the study population, as summarized in **Table 18**, are typical for an LVAD study performed in the U.S. The baseline characteristics of the two (2) arms were similar; there was no clinically significant difference in the severity of illness or treatments at the time of enrollment.

1.9 Destination Therapy Supplemental Study (continued)

Table 18: Patient Demographics and Baseline Characteristics in the ENDURANCE Supplemental Trial.

Demographics and Baseline Characteristics	HVAD (N=308)	Control (N=157)	P-value
Age (years)	63.3 ± 11.4	64.2 ± 11.1	0.39
Female gender (%)	18.2%	20.4%	0.62
Race (% White)	71.8%	75.2%	0.51
Height (cm)	175.0 ± 9.4	175.1 ± 9.8	0.91
Body Mass Index (kg/m ²)	28.2 ± 5.5	27.4 ± 5.2	0.13
INTERMACS Profile (%)			0.90
1	3.9%	2.5%	
2	32.8%	32.5%	
3	43.3%	43.3%	
4-7	20.0%	21.7%	
Ischemic Etiology of Heart Failure	55.2%	58.0%	0.62
History of smoking	68.2%	65.6%	0.60
Diabetic	49.4%	48.4%	0.92
Previous Stroke	10.4%	8.3%	0.51
Hypertension requiring medication	75.0%	72.0%	0.50
Atrial Fibrillation	50.6%	51.0%	> 0.99
Mean arterial blood pressure (mmHg)	78.9 ± 11.5 (N=296)	77.6 ± 11.1 (N=153)	0.23
Tricuspid regurgitation (≥ moderate)	40.4% (N=302)	44.2% (N=154)	0.48
Left ventricular ejection fraction (LVEF, %)	17.3 ± 5.1	18.2 ± 4.5	0.07
Previous intervention (%)			
ICD	80.8%	82.2%	0.80
CRT	28.9%	28.7%	> 0.99
IABP	19.2%	15.9%	0.45

Abbreviations: CRT=cardiac resynchronization therapy; ICD=implantable cardioverter defibrillator; LVEF=left ventricular ejection fraction.

Note: P-values are post-hoc and are included for information purposes only.

P-values comparing categorical values are from the Fisher's Exact Test. P-values comparing continuous values are from a two-sample t-test.

D. Safety and Effectiveness Results

1. Primary Endpoint

The outcome and analysis of the primary endpoint are shown in **Table 19** and **Figure 16**. The results show that 14.7% of the HVAD subjects experienced endpoint-defined neurologic injury as compared to 12.1% of the control subjects, with a difference of 2.6% between the two arms. The upper bound of the two-sided 90% exact binomial confidence interval of the difference in the neurologic injury incidence was 10.7%, which was above the pre-specified non-inferiority margin of 6%. Thus, the primary endpoint of the ENDURANCE Supplemental trial was not met.

1.9 Destination Therapy Supplemental Study (continued)

Table 19: Analyses of the Primary Endpoint

	HVAD (N=306)	Control (N=157)
Number of subjects who had a stroke/TIA at 12 months	58	24
Number of subjects who had a stroke at 12 months	51	23
Number of subjects who had a TIA at 12 months	13	1
Number of subjects who had mRS > 0 at 24 weeks post-stroke	38	18
Number of subjects who had spinal cord infarction at 12 months	0	0
Number of subjects with endpoint-defined neurologic injury events at 12 months	45 (14.7%)	19 (12.1%)
Difference of neurologic injury incidence	2.6%	
Two-sided 90% confidence interval	[-5.5%, 10.7%]	
Non-inferiority criteria	Fail	
p-value	0.1444	

Figure 16: ENDURANCE Supplemental Trial Primary Endpoint Survival

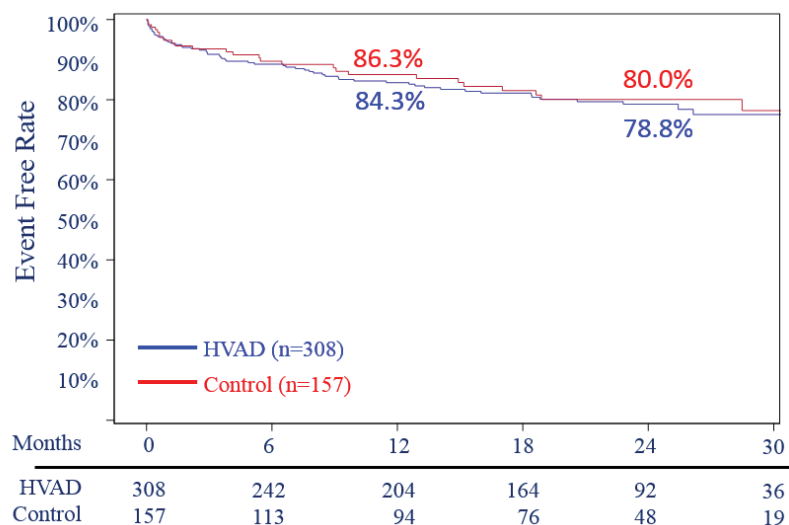

1.9 Destination Therapy Supplemental Study (continued)

2. Secondary Endpoints

Because the primary endpoint was not met, the hypotheses associated with the secondary endpoints of stroke/TIA incidence and stroke-free success rate could not be tested. Thus, only descriptive data are presented for the two secondary endpoints.

The incidence of stroke/TIA (inclusive of strokes with mRS = 0 at the 24 week time point) in HVAD patients was 19.2% at 12 months. The Time to event curve is shown in **Figure 17**.

Figure 17: ENDURANCE Supplemental Trial Survival Free from Stroke or TIA

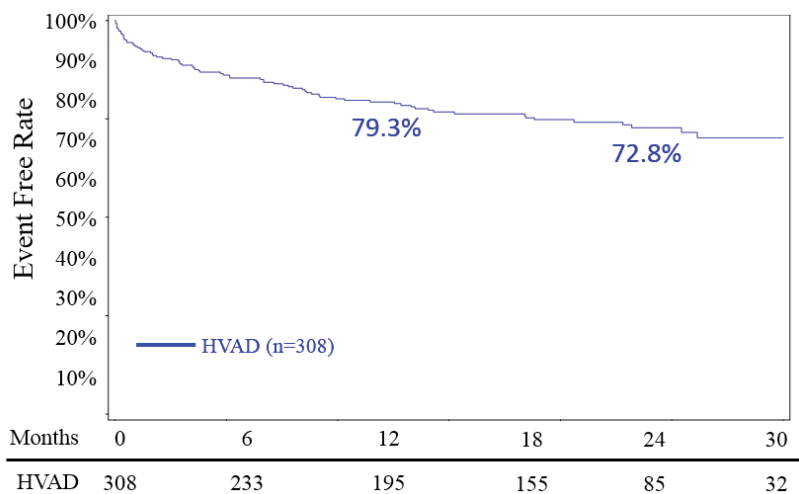

The proportion of subjects who survived to one year on the original device in the absence of “disabling” stroke (mRS ≥ 4), death, device exchange or urgent transplantation was 75.3% in the HVAD arm and 66.7% in the Control arm. A freedom from event analysis is shown in **Figure 17**, using data from March 27, 2017. The magnitude of the rate differential for this composite decreased with follow-up more analogous to the ENDURANCE trial’s 2-year endpoint time frame.

1.9 Destination Therapy Supplemental Study (continued)

Figure 18: ENDURANCE Supplemental Trial Survival Free from Death, Disabling Stroke or Device Malfunction/ Failure Requiring Exchange

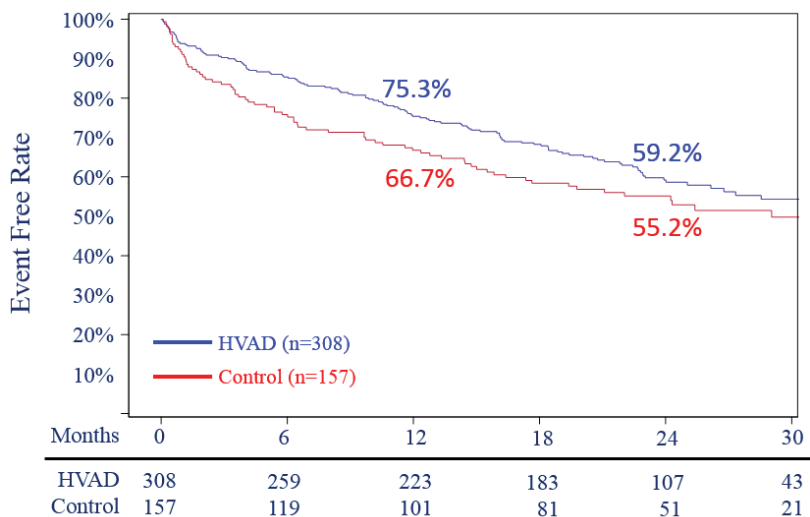

In the ENDURANCE Supplemental trial, freedom from ischemic stroke was numerically greater in the Control arm, as shown in **Figure 18**; freedom from hemorrhagic stroke was similar in HVAD and Control, as shown in **Figure 19**.

Figure 19: ENDURANCE Supplemental Trial Survival Free from Ischemic Stroke

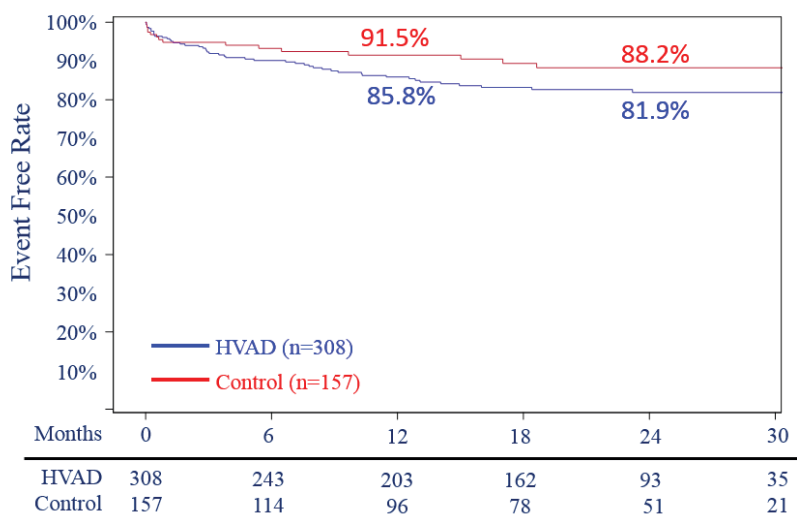

1.9 Destination Therapy Supplemental Study (continued)

Figure 20: ENDURANCE Supplemental Trial Survival Free from Hemorrhagic Stroke

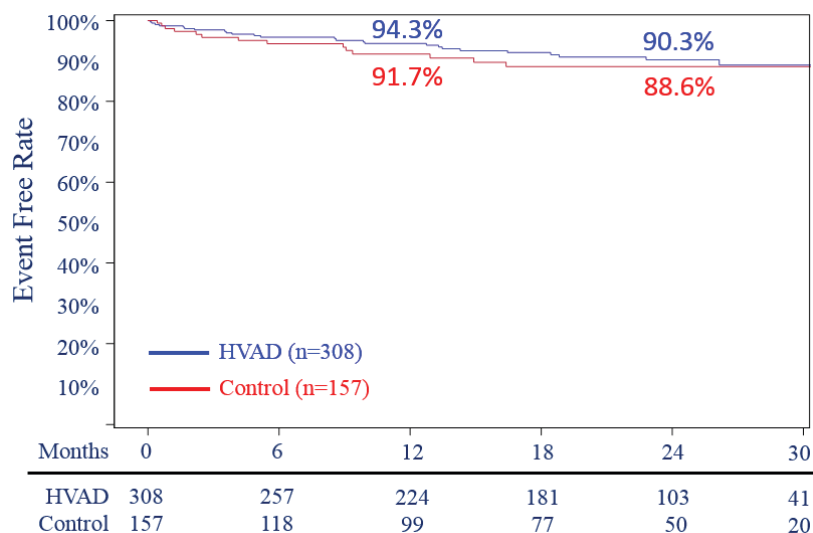

3. Adverse Events

Table 20 lists all the adverse events that occurred in the safety cohort.

Table 20: Summary of Adverse Events at 1 Year in the ENDURANCE Supplemental Trial.

Adverse Event	HVAD (N=308)	Control (N=157)
Major Bleeding	51.6% (159)	56.7% (89)
Cardiac Arrhythmia	34.1% (105)	31.2% (49)
Hepatic Dysfunction	3.9% (12)	3.8% (6)
Hypertension	13.0% (40)	12.7% (20)
Major Infection	53.9% (166)	59.2% (93)
Driveline Exit Site Infection	16.2% (50)	12.1% (19)
Device Malfunction/Failure	24.0% (74)	24.2% (38)
Hemolysis	1.3% (4)	5.7% (9)
Stroke	16.9% (52)	14.6% (23)
Ischemic Cerebrovascular Event	13.0% (40)	7.6% (12)
Hemorrhagic Cerebrovascular Event	5.2% (16)	7.0% (11)
TIA	4.2% (13)	0.6% (1)
Renal Dysfunction	10.4% (32)	14.6% (23)
Respiratory Failure	19.8% (61)	19.7% (31)
Right Heart Failure	35.4% (109)	38.2% (60)
Pump Replacement	5.2% (16)	11.5% (18)
Exchange for Pump Thrombosis	4.5% (14)	10.2% (16)

1.9 Destination Therapy Supplemental Study (continued)

Stroke-related Deaths

Within the mITT population, the CEC-adjudicated rate of stroke-related death within 1 year of implantation was 3.2% (10/308) for HVAD patients and 2.5% (4/157) for Control patients.

Comparing the results of ENDURANCE and ENDURANCE Supplemental, the rates of stroke-related death decreased by the same proportions (approximately 58%) for both HVAD and Control arms; only the HVAD arm was exposed to the trial's investigational intervention of a blood pressure management protocol. The stroke-related deaths are compared in **Table 21**. The MAP over time from the ENDURANCE Supplemental trial for the HVAD compared to the Control is shown in **Figure 21**.

Table 21: Stroke-related Deaths in ENDURANCE and ENDURANCE Supplemental Trials

	ENDURANCE Within 2 years of implant (AIP)	ENDURANCE Supplemental Within 1 year of implant (mITT)
HVAD	25/296 (8.4%)	10/308 (3.2%)
HMII (control)	9/149 (6.0%)	4/157 (2.5%)

Figure 21: ENDURANCE Supplemental Trial MAP over Time

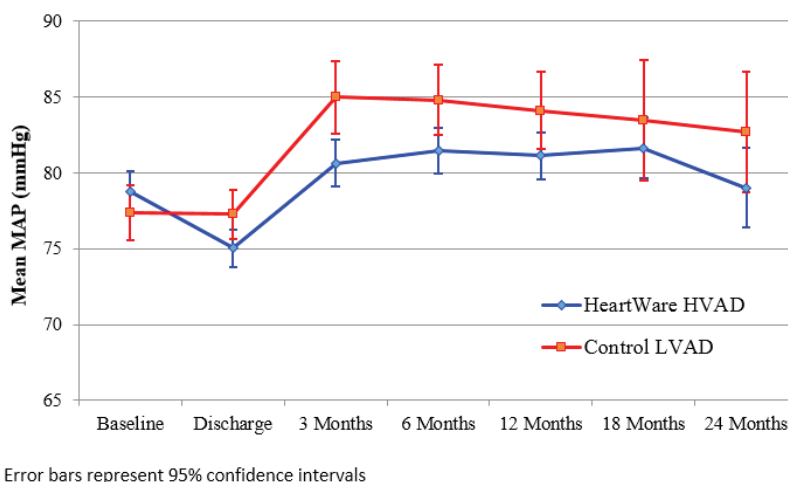

Health Status and Functional Improvements

The improvements in quality of life, as measured by the KCCQ and EQ-5D-5L, and functional capacity, as measured by the 6 minute walk test and NYHA Class improvement, in the ENDURANCE Supplement trial patients are presented in **Figure 22**.

1.9 Destination Therapy Supplemental Study (continued)

Figure 22: Improvements in Quality of Life and Functional Capacity in ENDURANCE Supplemental Subjects. A) Change over time of the KCCQ Overall Summary Score. B) Change over time in the EQ-5D Visual Analog Scale. C) Change over time of total distance walked in the Six Minute Walk Test. D) Percent of patients with 2 or more class increase in NYHA Classification at 12 months compared to baseline.

A. KCCQ

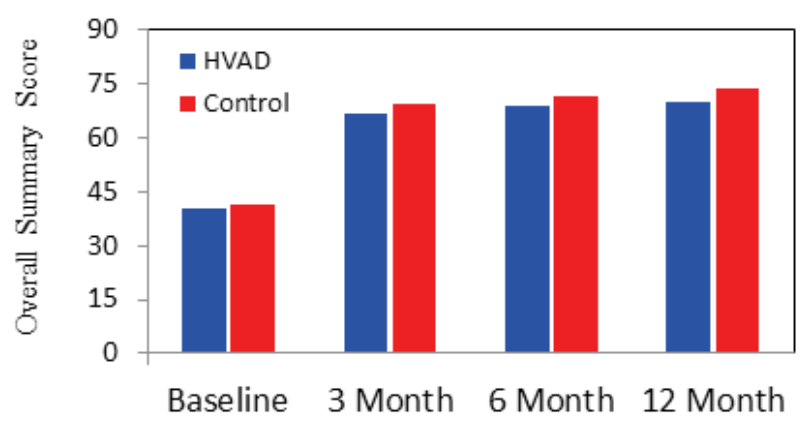

B. EQ-5D

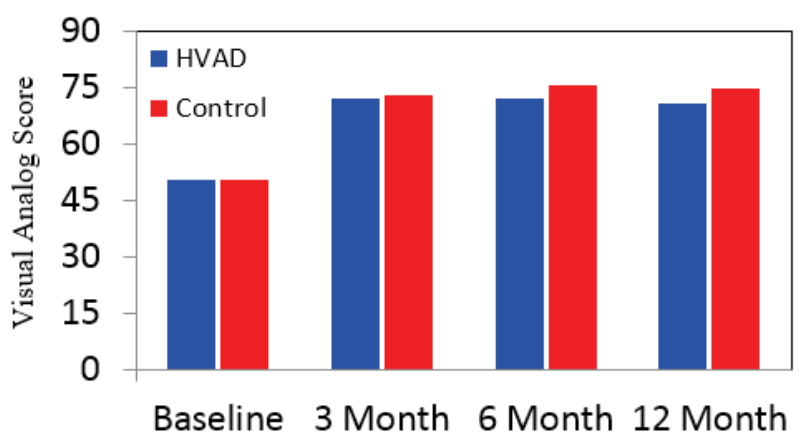

1.9 Destination Therapy Supplemental Study (continued)

C. Six-Minute Walk

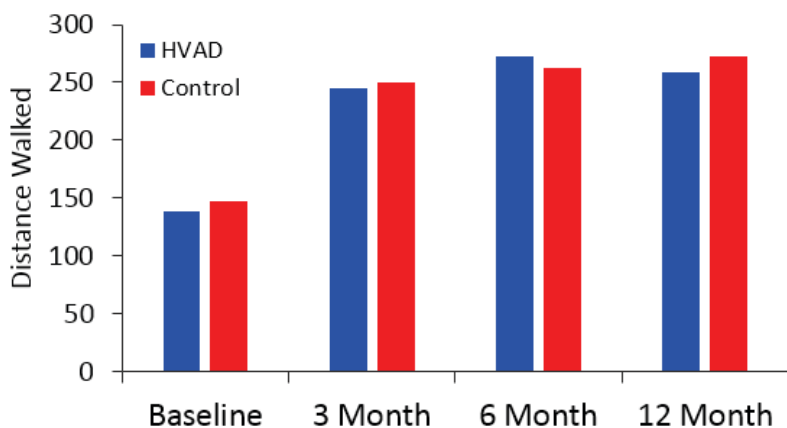

D. NYHA Classification Improvement

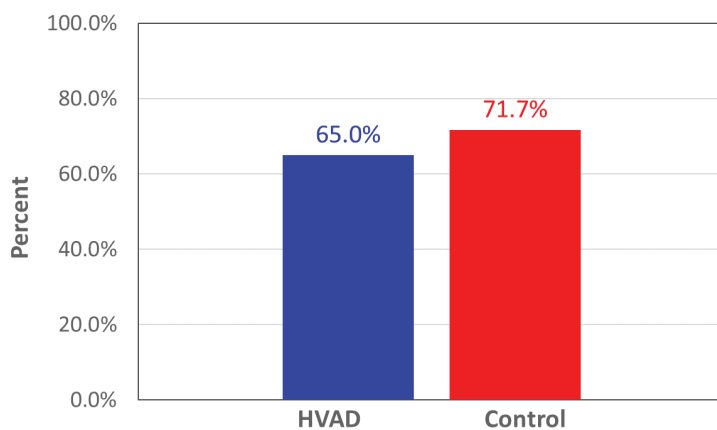
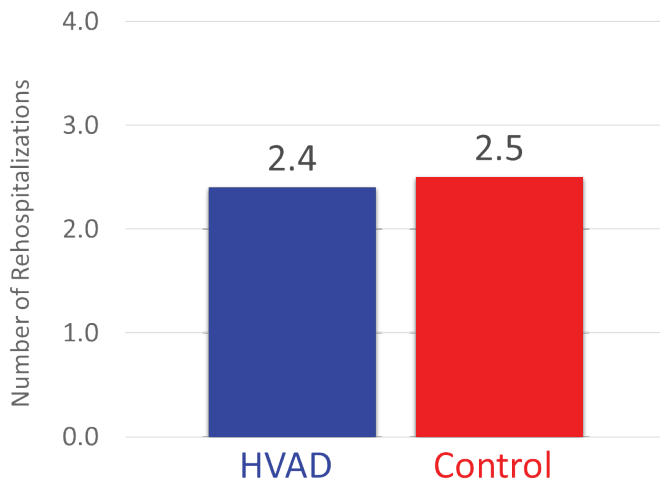

Figure 23: Average Number of Rehospitalizations in the First Year Post Implant in the ENDURANCE Supplemental Trial



1.9 Destination Therapy Supplemental Study (continued)

Subgroup Analyses

The following preoperative characteristics were evaluated for potential association with outcomes: gender, BSA (<1.5 m², ≥1.5 m²). No associations to outcomes of the primary and secondary endpoints were found for these two preoperative characteristics.

Conclusions from the ENDURANCE Destination Therapy Supplemental Trial

The ENDURANCE Supplemental trial did not meet its pre-specified primary endpoint, a demonstration of non-inferiority of the HVAD to the control device for freedom from neurologic injury (stroke with mRS >0 at 24 weeks post stroke or a transient ischemic attack) at 12 months (HVAD: 14.7% vs control: 12.1%). The combined rate of stroke and TIA in HVAD patients at one year did not meet a performance goal derived from the rate observed in ENDURANCE. Survival at 1 year free from the composite of disabling stroke or device exchange favored the HeartWare™ HVAD™ System (HVAD: 75.3% vs control: 66.7%), though the trend diminished in magnitude over time (at 2 years, HVAD: 59.2% vs Control: 55.2%). The HeartWare™ HVAD™ System and Control both demonstrated sustained improvements in quality of life, functional capacity, and NYHA classification. Finally, although the HVAD failed to demonstrate non-inferiority compared to Control for incidence of neurological injury at one year, the implementation of a blood pressure management strategy for HVAD recipients did demonstrate a reduction in the overall stroke rates in patients receiving an HeartWare™ HVAD™ System.

Overall Conclusions

The overall safety comparisons in both the ENDURANCE and ENDURANCE Supplemental trials resulted in similar mortality rates and adverse event profiles. Pump thrombosis rates for the sintered HVAD and the Control LVAD were similar, but a higher proportion of Control pump thrombosis events resulted in device exchange. The incidence of stroke was 2.5 times higher in the patients receiving an HVAD compared to control in the ENDURANCE trial. The ENDURANCE Supplemental trial, which included implementation of a blood pressure management strategy for HVAD recipients, demonstrated a reduction in the overall stroke rates in patients receiving an HeartWare™ HVAD™ System, though HVAD failed to demonstrate non-inferiority compared to Control for incidence of neurological injury at one year.

The data supports the reasonable assurance of safety and effectiveness of the HeartWare™ HVAD™ System for hemodynamic support in patients with advanced, refractory left ventricular heart failure; either as a bridge to cardiac transplantation (BTT), myocardial recovery, or as destination therapy (DT) in patients for whom subsequent transplantation is not planned.

1.10 North American Clinical Study: LATERAL

HeartWare™ HVAD™ System Clinical Trial Overview: LATERAL Trial

This was a multi-center, prospective, open-label non-randomized single arm trial conducted in collaboration with the InterAgency Registry for Mechanically Assisted Circulatory Support (INTERMACS®) to Evaluate the Thoracotomy Implant Technique of the HeartWare™ HVAD™ System in Patients with Advanced Heart Failure. Enrollment in the study is complete, subjects have all reached the primary endpoint as described and specified in the protocol, but follow-up of subjects is ongoing.

A. Study Design

Patients were enrolled between January 15, 2015 and April 26, 2016. The study data was collected through June 15, 2017 and included 144 subjects treated per protocol who were enrolled at 26 investigational sites.

The study was a prospective, single arm, multi-center clinical study in collaboration with the InterAgency Registry for Mechanically Assisted Circulatory Support (INTERMACS®) to evaluate the thoracotomy implant technique of the HeartWare™ HVAD™ System in patients with advanced heart failure. The study device was the HVAD (HeartWare Ventricular Assist Device) System. The treatment was open-label.

Following implantation, device performance, follow-up visits and visit windows for the LATERAL Study are dictated by the INTERMACS protocol.

Adverse events (AE) were reported through INTERMACS, according to the INTERMACS AE definitions. An independent Data Safety Monitoring Board monitored and reviewed study compliance, adverse events and outcomes.

An NHLBI-appointed (independent) Observational Study Monitoring Board (OSMB) was established in 2006 and meets, at minimum, on an annual basis. The principal role of the OSMB is to monitor data from the Registry, review and assess the performance of its operations, assure patient safety, and make recommendations to the NHLBI and INTERMACS co-investigators.

1. Clinical Inclusion and Exclusion Criteria

Enrollment in the LATERAL Study was limited to subjects who met the following inclusion criteria:

- Subjects >19 years old with chronic, advanced left ventricular failure who were transplant eligible at the time of enrollment in whom informed consent was obtained.

Subjects were not permitted to enroll in the LATERAL Study if they met any of the following exclusion criteria:

- Subjects with a body surface area < 1.2 m²
- Subjects with prior cardiac transplant
- Subjects with a mechanical heart valve
- Subjects with severe right heart failure or receiving biventricular or the device as a right ventricular assist device
- Subjects with a planned concurrent procedure
- Subjects with known LV thrombus
- Additional exclusion criteria are available in the Clinical Study Report.

1.10 North American Clinical Study: LATERAL (continued)

2. Follow-up Schedule

Preoperative baseline assessments included demographics, medical history, concurrent medications, laboratory tests, echocardiogram, NYHA, neurocognitive status, quality of life, and functional status.

All patients were scheduled to return for follow-up examinations at Week 1 +/- 3 days, Month 1 +/- 7 days, Month 3 +/- 30 days, Month 6 +/- 60 days (primary endpoint), and every 6 months +/- 60 days through 5 years of follow-up.

Week 1 and Month 1 visits included clinical laboratory tests for hematology, chemistry and INR, LVAD parameters, concurrent medications, echocardiogram, and assessments of NYHA. Months 3, 6 and onward also included health status, six-minute walk and an assessment of neurocognitive status.

Adverse events and complications were recorded at all visits.

The key timepoints are shown below in the tables summarizing safety and effectiveness.

3. Clinical Endpoints

The primary endpoint was a composite of six-month survival free of disabling stroke (i.e., modified Rankin score ≥ 4 assessed 12 weeks post-event), while alive on the originally implanted device, transplanted or explanted due to left ventricular recovery.

Success in meeting the primary endpoint was tested comparing to a performance goal (77.5%) using a one-sided exact binomial test. Success will be met if the lower bound of the one-sided exact 95% confidence limit is greater than 77.5%. Success at six months is estimated to be 86% compared to a performance goal of 77.5%. The target success estimate was based on the primary endpoint observed in the ADVANCE BTT+CAP Trial, post-approval data on HVAD outcomes from the INTERMACS Registry (through Q2 2014), and the INTERMACS report from Q1 2014 indicating an 85% survival estimate with LVAD support. Using an exact binomial test, with a one-sided alpha of 0.05, and 80% Power, a sample size of 145 implanted subjects was planned.

The prespecified secondary endpoint is an improvement in the mean length of initial hospital stay as compared to a performance goal of median sternotomy subjects. The mean length of initial hospital stay is estimated to be 26.1 days with a standard deviation of 22.8 days and a median of 20 days based on data from the Bridge to Transplantation Continued Access Protocol (BTT CAP) population (N=242). Using a one sample t-test, with a one-sided alpha of 0.05, a sample of 145 implanted subjects with an average value of 21.3 days or less will result in Power greater than 80%.

Other secondary endpoints included the incidence of major adverse events (classified according to the INTERMACS definitions), overall survival, changes in quality of life and health status as assessed by the KCCQ and the EQ-5D VAS, and functional status, as measured by NYHA functional class and 6-minute walk distance. The safety analysis focused on adverse events. Survival analysis was performed using the Kaplan-Meier method.

With regards to safety, predetermined secondary endpoints included the incidence bleeding, major infections, and overall survival. Additionally, incidence of device malfunctions/failures, quality of life and health status changes, as well as major adverse events (classified according to the INTERMACS definitions) were analyzed.

1.10 North American Clinical Study: LATERAL (continued)

B. Accountability of Cohort

At the time of the data cut-off for this analysis (June 15, 2017), of the 178 patients enrolled in the LATERAL study, with 158 subjects qualifying for the analysis population, 98.7% (156) subjects were available for analysis of the primary objective at the completion of the study, the 6-month post-operative visit. The disposition of patients is shown in **Figure 24**.

The primary analysis population is the Per Protocol (PP) population, including a total of 144 subjects implanted with an HVAD via a thoracotomy approach and meeting all inclusion criteria without violating any exclusion criteria. The mean duration of subjects on original device in the PP population is 12.1 months. Eleven (11) additional subjects were included in the intent-to-treat population. Of the 23 screen failures, 3 subjects were implanted via a thoracotomy and were thus included in additional secondary endpoint analyses.

Figure 24: Subject Enrollment and Study populations in the LATERAL study.

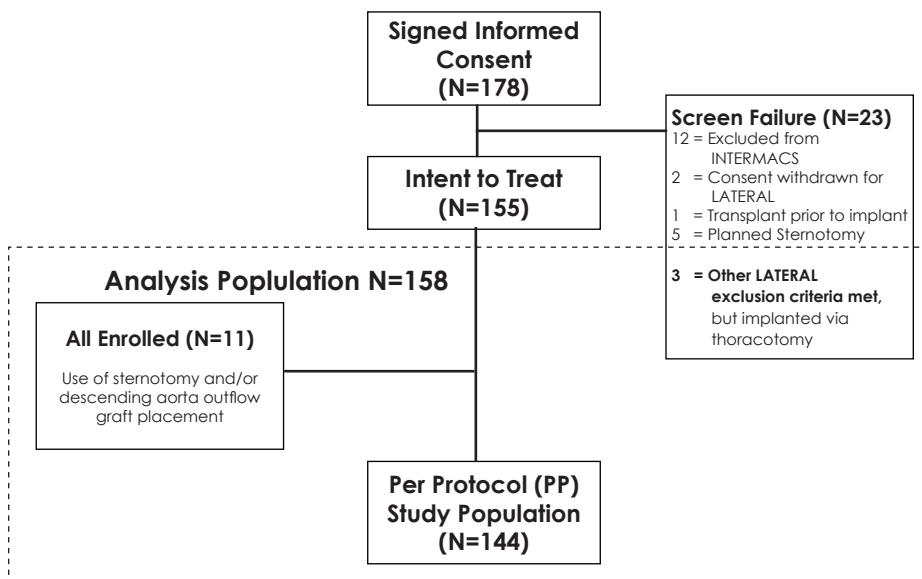

The purpose of the LATERAL Study was to evaluate the safety and effectiveness of the implanting the HeartWare™ HVAD™ System by a thoracotomy approach, therefore patients in whom an implant via sternotomy was planned were screen failed from the study. Additionally, subjects in whom thoracotomy was planned, but then were implanted via a sternotomy, or those in whom the outflow was implanted in the descending aorta rather than the ascending aorta were included in the intent to treat population. Finally, those patients who violated one or more of the exclusion criteria, but in whom a thoracotomy implant was still completed, were included in the analysis population. All thoracotomy implant procedures were also recommended to be completed on cardiopulmonary bypass.

Study Population Demographics and Baseline Parameters

The demographics of the primary study population are typical for an advanced heart failure with LVAD therapy study performed in the US. The subjects in the trial had advanced heart failure associated with a substantial risk of death, as evidenced by over 80% of subjects classified as INTERMACS Profile 1-3, almost 20% with chronic renal disease, and more than 60% with ejection fractions lower than 20%. See **Table 22**.

1.10 North American Clinical Study: LATERAL (continued)

Table 22: Baseline Demographics and Parameters in LATERAL

Demographics and Baseline Characteristics	Study Device N=144
Age (years)	54.2 ± 11.5
Male gender (%)	77.1%
Race (%)	
White	62.5%
Black or African American	20.8%
Asian	4.9%
American Indian or Alaskan Native	2.1%
Other, none of the above	4.9%
Unspecified, Undisclosed	7.6%
Height (cm)	175.2 ± 8.8
Body Surface Area (m ²)	2.0 ± 0.3
Intended use	
Bridge to Transplant	73.6%
Possible Bridge to Transplant	26.4%
INTERMACS Profile (%)	
1	3.5%
2	31.3%
3	47.2%
4	15.3%
5-7	2.8%
Ischemic Etiology of Heart Failure	32.6%
Prior Cardiac Surgery	22.9%
Previous Major Stroke	4.9%
Chronic Renal Disease	18.8%
History of Atrial Arrhythmias	30.6%
Serum creatinine (mg/dL)	1.3 ± 0.74
Mean Arterial Blood Pressure (mmHg)	79.5 ± 10.5
Left ventricular ejection fraction <20% (LVEF, %)	61.1%
Cardiac Index (L/min/m ²)	2.1 ± 0.54

C. Safety and Effectiveness Results

1. Primary Endpoint

The outcome and analysis of the primary endpoint are shown in **Table 23**. The primary endpoint success in the LATERAL Study was defined as alive on original device, transplanted or explanted for recovery without a stroke with an mRS score of ≥ 4 (assessed \geq three months post-stroke event). One subject had missing data for this endpoint, which resulted in 143 evaluable subjects. The results show that 88.1% of the HVAD subjects treated per protocol achieved primary endpoint success, which was significantly greater than the 77.5% performance goal ($P=0.0012$). The most common reason for primary endpoint failure was death on original device, seen in 7.7% (11/143) of subjects (**Table 23**). Protocol-mandated stroke assessments were not carried out in all subjects who experienced a stroke. In addition, 6 patients were reported as having a stroke within the first 6 months of implant. 3 of these 6 patients do not have sufficient data on mRS scores and the severity of their strokes could not be determined. The Primary Endpoint for these 3 patients are based upon post hoc imputation of mRS scores.

1.10 North American Clinical Study: LATERAL (continued)

Table 23: Primary Endpoint at Six Months*

Thoracotomy (N=143)	N (%)	95% CI *
Primary Endpoint Success	126 (88.1%)	0.0012 (82.7%, NA)
Alive on original device	97 (67.8%)	
Transplanted	29 (20.3%)	
Explanted for Recovery	0 (0.0%)	
Primary Endpoint Failure	17 (11.9%)	
Death on original device	11 (7.7%)	
Stroke with mRS \geq 4 (as assessed \geq 3 Months post event)	4 (2.8%)	
Exchange	1 (0.7%)	
Explanted (not for recovery)	1 (0.7%)	

*Table is summarized by subjects' first failure event and includes all subjects with an endpoint event prior to 6 months or known to be alive on original device at 6 months.

**P-value of one-sided Binomial Exact test comparing to a performance goal of 77.5%

*** Subject considered a success if all strokes have day of and follow-up mRS scores $<$ 4.

2. Secondary Endpoints

For the PP population, the mean length of initial hospital stay (initial recovery and step down unit) after the implant procedure (date of implant to first discharge) was 18 ± 12.36 days, which is significantly less than the 26.1 day performance goal estimate for median sternotomy subjects. ($P < 0.0001$). Additionally, the mean length of stay in the intensive care unit (ICU) was 8 ± 9.82 days. Results in the ITT population were similar.

Rehospitalization in the PP population was documented in 70.1% of subjects within 6 months of initial hospitalization. The most common reasons for re-hospitalization were transplant (27.7%), anticoagulation adjustment (19.8%), and major bleeding (17.8%). A freedom from rehospitalization is presented in **Figure 25**.

Figure 25: Time to Rehospitalization in LATERAL (PP Population, N=144)

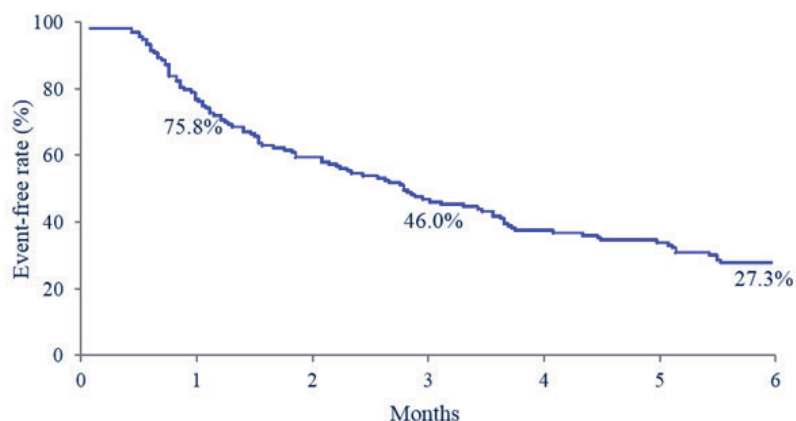

1.10 North American Clinical Study: LATERAL (continued)

Overall survival on the HeartWare™ HVAD™ System was also assessed. A Kaplan-Meier estimate for freedom from death on original device for the PP population was 91.8% at 6 months, 88.8% at one year, and 87.4% at two years (**Figure 26**). The Kaplan-Meier estimates in the ITT population were similar.

Figure 26: Kaplan Meier Survival Analysis in the LATERAL Study (N=144)

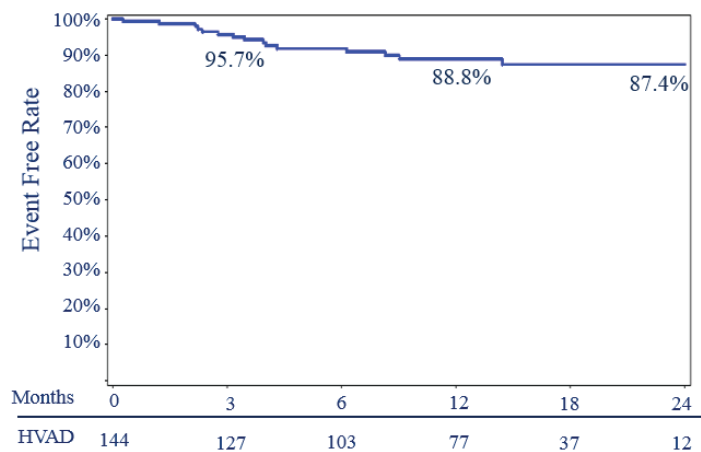

Six of 11 deaths occurring within the first 6 months post-implant were related to circulatory causes, with two due to right heart failure (1.4%) and two due to sudden unexplained death (1.4%). The most common non-cardiovascular cause of death was neurological dysfunction, which occurred in three subjects (2.1%). Additionally, one subject died of multi-system organ failure and another after withdrawal of life support.

1.10 North American Clinical Study: LATERAL (continued)

Health Status and Functional Improvements

The improvements in quality of life, as measured by the KCCQ and EQ-5D-5L, and functional capacity, as measured by the 6-Minute Walk Test and NYHA Class improvement, in the LATERAL Study subjects are presented in **Figure 27A-D**.

Figure 27: Improvements in Quality of Life and Functional Capacity in ENDURANCE Supplemental Subjects. A) Change over time of the KCCQ Overall Summary Score. **B)** Change over time in the EQ-5D Visual Analog Scale. **C)** Change over time in subjects' NYHA Classification. **D)** Change over time of total distance walked in the Six Minute Walk Test.

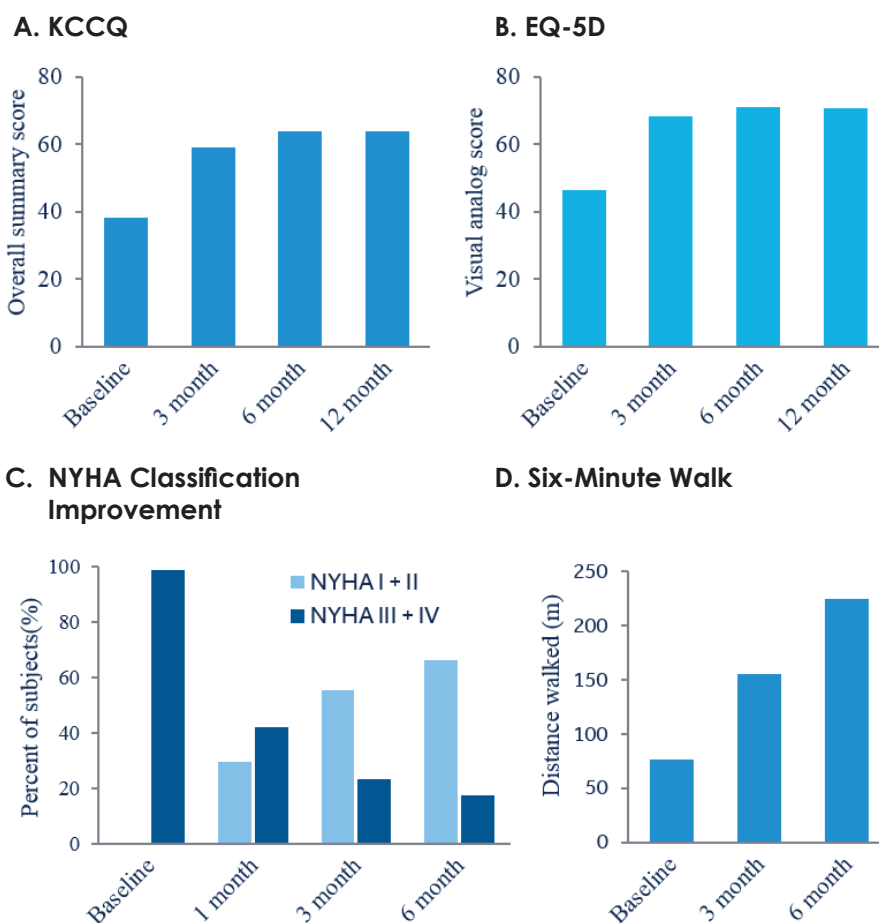

3. Adverse Events

The analysis of safety was based on the per protocol cohort of 144 patients analyzed through the primary endpoint. A Clinical Events Committee (CEC) was not utilized in this study for adverse event adjudication. A total of 537 INTERMACS adverse events were reported within 6 months on original device. Adverse events were most often reported within the first 30 days post-implant, with 87.5% (126/144) subjects having at least one INTERMACS-defined adverse event.

The most common adverse events were cardiac arrhythmia, bleeding, and infections. Adverse events are summarized in **Table 24**.

1.10 North American Clinical Study: LATERAL (continued)

Table 24: Summary of INTERMACS Adverse Events Occurring Through 6 Months

INTERMACS Category Adverse Events	≤30 Days (N=143)	> 30 Days – 6 Months (N=140)
Total Adverse Events	126 (87.5)	89 (63.6)
Bleeding	15 (10.4)	20 (14.3)
Re-Hospitalization	5 (3.5)	14 (10.0)
Re-Operation	5 (3.5)	3 (2.1)
Transfusion: ≥4 within 7 days	13 (9.0)	16 (11.4)
GI	6 (4.2)	11 (7.9)
Cardiac Arrhythmia	32 (22.2)	13 (9.3)
Ventricular	20 (13.9)	9 (6.4)
Supraventricular	13 (9.0)	2 (1.4)
Device Malfunction/Failure	9 (6.3)	10 (7.1)
Hepatic Dysfunction	1 (0.7)	0 (0.0)
Infection	20 (13.9)	32 (22.9)
Line Sepsis	0 (0.0)	1 (0.7)
Driveline Exit Site	2 (1.4)	7 (5.0)
Myocardial Infarction	0 (0.0)	0 (0.0)
Neurological	12 (8.3)	12 (8.6)
Ischemic CVA	3 (2.1)	3 (2.1)
Hemorrhagic CVA	3 (2.1)	3 (2.1)
TIA	1 (0.7)	4 (2.9)
Psychiatric	3 (2.1)	2 (1.4)
Renal Dysfunction	8 (5.6)	6 (4.3)
Respiratory Dysfunction	11 (7.6)	2 (1.4)
Arterial non-CNS Thromboembolism	0 (0.0)	0 (0.0)
Venous Thromboembolism	4 (2.8)	1 (0.7)
Wound Dehiscence	1 (0.7)	2 (1.4)
Other	20 (13.9)	22 (15.7)

abbreviations: GI - gastrointestinal; TIA= transient ischemic attack (<24 hours)

Nineteen of 143 subjects were reported to have experienced a stroke within six months post-implant, of which two were severely disabling with a mRS ≥ 4 at three months post-stroke. Functional assessment of stroke was specified in the protocol; degree of follow-ups is shown in **Table 25**.

1.10 North American Clinical Study: LATERAL (continued)

Table 25: Summary of Stroke Events

Patient ID	Primary End-point Population (Y/N)	Primary End-point Success (Y/N)	Endpoint Type	mRS at Stroke Event	Time to Stroke Event (Months)	1 Week Post Implant Follow up mRS	1 Month Post Implant Follow up mRS	3 Months Post Implant Follow up mRS	6 Months Post Implant Follow up mRS	12 Months Post Implant Follow up mRS	18 Months Post Implant Follow up mRS	24 Months Post Implant Follow up mRS
102 899	N				2.726 955							
103 374	Y	N	Stroke with mRS >= 4	5	0	5	4	4	4	4	4	4
103 481	Y	Y	Alive Original Device		21.74 993		0		0			
103 573	Y	N	Death	5	3.876 876							
103 799	Y	Y	Alive Original Device	4	0.032 855	4	0	0	0	0	0	0
103 825	Y	Y	Alive Original Device		6.340 993					0	0	
103 984	Y	N	Stroke with mRS >= 4	5	0.032 855	5						
105 103	Y	Y	Transplanted	1	0.032 855	1	2	0				
105 184	Y	N	Stroke with Missing mRS	0	3.646 892			0	0			
105 534	Y	Y	Alive Original Device	1	13.99 618							
105 799	Y	N	Stroke with Missing mRS		4.928 233				1			
106 048	N				4.041 151							
106 239	Y	Y	Explanted for Recovery	2	16.72 314							
106 358	Y	N	Stroke with mRS >= 4		2.529 826				2	3		
106 667	Y	Y	Alive Original Device	2	0.427 113		1	1	1	1		
107 394	Y	N	Death		0.919 937							
107 558	Y	Y	Alive Original Device		15.11 325							
108 106	Y	Y	Alive Original Device		10.97 353							
108 131	Y	N	Death		2.891 23							
108 257	Y	Y	Alive Original Device		7.688 043							

* Grey indicates prior to stroke event

1.10 North American Clinical Study: LATERAL (continued)

INTERMACS data collection methods for hemolysis, hypertension and right heart failure (RHF) adverse events differ from other adverse events. Specifically, events were triggered based on data entered at each patient visit rather than site-reporting of specific events as they occur. This method results in a potential difference in reporting of event frequency. These events are no longer site-reported events per se.

A major hemolysis event was triggered in 11.2% (16/143) of subjects at one-week post-implant based on INTERMACS-defined criteria, and to date this value has not changed substantially over the follow-up period. Severe hemolysis incidence appears greater than previously reported in HVAD studies, however, these are not site-reported events so comparisons cannot be made.

Moderate and severe right heart failure (RHF) events were triggered in 69.9% (100/143) and 0.7% (1/143) of subjects, respectively, at one-week post-implant based on INTERMACS-defined criteria. Though the incidence of severe RHF was low, the incidence of moderate or severe RHF appears to be greater than RHF adverse events previously reported in HVAD studies. However, once again it should be noted that these are triggered events and not site-reported, so comparisons to previous reports cannot be appropriately made.

No unanticipated adverse device effects were reported in the LATERAL Study.

The prevalence of device failure/malfunction in the per protocol population was 12.5%. In a majority of these cases, no cause was identified. There were 5 cases of suspected or confirmed pump thrombosis identified by hemolysis (2/5) and/or abnormal pump parameters (4/5). One case was confirmed as pump thrombosis.

Table 26: Device Malfunction/Failure or Pump Thrombosis within 6 months

Adverse Event	N=144 % (N)
Device Malfunction/Failure and/or Pump Thrombus	12.5% (18)
Outcome	
Death	0% (0)
Serious Injury	0% (0)
Urgent Transplantation	0% (0)
Explant without Replacement	0% (0)
Exchange	2.8% (4)
Breach of Integrity of Driveline that Required Repair	0% (0)
None of the Above	9.7% (14)
Causative or Contributing Factors	
Patient Accident	0.7% (1)
Patient Non-Compliance	0% (0)
Sub Therapeutic Anticoagulation	0.7% (1)
Prothrombotic States	0% (0)
End of Component Expected Life	0% (0)
Technical/Procedural Issues	2.8% (4)
No Cause Identified	9.0% (13)
Thrombus (Suspected or Confirmed)	3.5% (5)

1.10 North American Clinical Study: LATERAL (continued)

4. Subgroup Analyses

Subgroup analyses were planned for analysis of the primary endpoint analysis using stratification factors site, on- vs. off-cardiopulmonary bypass pump, and outflow graft location. An analysis of site homogeneity found that the primary endpoint results were significantly different by site ($P = 0.035$). Further analyses found no predictive factors.

Across all populations, only one ITT subject had alternative outflow location. The subject is currently alive on original device. Similarly, only one subject had no indication in his records regarding use of cardiopulmonary bypass, and that subject was transplanted. Due to the sparse nature of these data, no additional analyses were performed.

Overall Conclusions from the LATERAL Trial

The LATERAL Trial was a multi-center, prospective, contemporaneous controlled study. The purpose of this study was to evaluate the safety and effectiveness of HVAD implantation via the thoracotomy approach. The analysis of the primary endpoint suggested success of the HeartWare™ HVAD™ System implanted via thoracotomy compared to the performance goal. The most common reason for primary endpoint failure was death on original device, seen in 7.7% (11/143) of subjects.

An improvement in mean length of initial hospital stay was also observed, with a mean length of stay of 18 ± 12.36 days as compared to the 26.1 day performance goal.

HVAD implantation via thoracotomy appears to be safe, with adverse event rates that are comparable to previous HVAD studies, with the exception of hemolysis and right heart failure which may be partially related to data collection methods.

Overall, HVAD implantation via the thoracotomy approach appears to be effective, with the achievement of statistical significance in the LATERAL primary and secondary endpoints. Additionally, overall quality of life and functional capacity were meaningfully improved in LATERAL subjects.

+ 2.0 HeartWare™ HVAD™ System Overview

2.1 HVAD® Pump and Surgical Tools.....61

2.2 HVAD® Controller.....62

2.3 HeartWare® Monitor63

2.4 HVAD® Controller Power Sources.....63

2.5 HeartWare® Battery Charger64

2.6 Carrying Cases and Shower Bag.....64

System Component Overview

See Appendix A for a complete list of system components.

The primary components of the HeartWare™ HVAD™ System (excluding the Monitor) are intended for single patient use.

STERILE: All HeartWare implantable components, surgical tools and accessories used at implant are provided sterile.

2.1 HVAD® Pump and Surgical Tools

The HeartWare™ HVAD™ System consists of a blood pump with an integrated, partially sintered inflow cannula; a 10 mm diameter gel impregnated polyester outflow graft, and a percutaneous driveline. A strain relief is used on the outflow graft to prevent kinking and secures the outflow graft to the pump. The driveline cable is wrapped with woven polyester fabric to encourage tissue in-growth at the skin exit site. The small, wearless pump has a displaced volume of 50cc and weighs 160 grams. The pump has one moving part, an impeller, which spins blood to generate up to 10.0 L/min of flow. There are two motors in the pump housing with one motor providing redundancy.

A short integrated inflow cannula is inserted into the left ventricle and the outflow graft connects the HVAD® Pump to the aorta. A sewing ring attaches to the myocardium and allows for pump orientation adjustments intraoperatively. The device size and short inflow cannula allow for pericardial placement, which eliminates the need for abdominal surgery and device pockets (Figure 28).

Figure 28: HVAD® Pump and Left Ventricular (LV) Cannulation

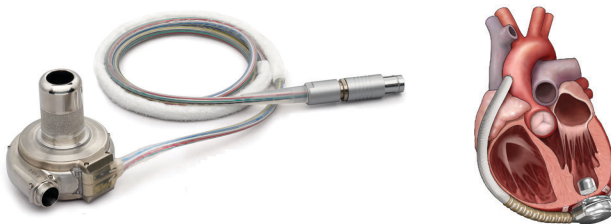

For additional information about the HVAD® Pump, see Section 3.0.

2.1 HVAD® Pump and Surgical Tools (continued)

Surgical Tools and Accessories are Provided Sterile Surgical Implantation.

Figure 29: Surgical Tools

1. **Tunneler** – to tunnel the pump's percutaneous driveline through the skin to the exit site
2. **Sewing ring wrench** – to tighten the screw on the sewing ring
3. **Driveline cover** – to cover the driveline connection to the controller
4. **Apical coring tool** – to core the LV apex
5. **Hex driver** – to secure the strain relief and outflow graft to the HVAD® Pump

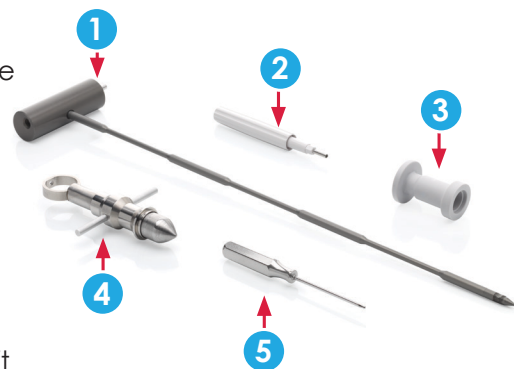

Figure 29

All tools and accessories used during implantation are for single-use only.

Figure 30: Components used at Implant

1. **HVAD® Pump**
2. **Outflow graft**
3. **Sewing ring**
4. **Driveline cap**
5. **Strain relief**
6. **Inflow cap**
7. **Driveline extension cable**



Figure 30



For additional information on implantation, see Section 6.0.

2.2 HVAD® Controller

The controller (**Figure 31**) is a microprocessor unit that controls and manages HeartWare™ HVAD™ System operation. It sends power and operating signals to the blood pump and collects information from the pump. The percutaneous driveline is connected to the controller, which must always be connected to two power sources - an AC adapter or DC adapter and/or rechargeable batteries. The controller's internal, non-replaceable, rechargeable battery is used to power an audible [No Power] alarm when both power sources are disconnected. The controller interfaces with the monitor through a data port.

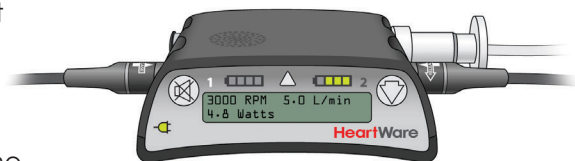

Figure 31

2.2 HVAD® Controller (continued)



CAUTION: ONLY use HVAD® Controllers on one patient to avoid risks associated with an inadvertent mismatch of controller pump speed settings.



For additional information about the HVAD® Controller, see Section 4.2.

2.3 HeartWare® Monitor

The monitor (**Figure 32**) is a touch screen tablet that uses proprietary software to display system performance and to permit adjustment of selected controller parameters. When connected to a controller, the monitor receives continuous data from the controller and displays real-time and historical pump information. The monitor also displays alarm conditions and can provide notification of available controller software updates.



Figure 32



For additional information about the HeartWare® Monitor, see Section 5.0.

2.4 HVAD® Controller Power Sources

The controller requires two power sources for safe operation: either two batteries, or one battery (**Figure 33**) and an AC adapter (**Figure 34**) or DC adapter (**Figure 35**). While active, patients will typically use two batteries. While relaxing or sleeping, patients should use power from an electrical outlet (AC adapter) because it provides power for an unlimited period of time.

Figure 33



Figure 34

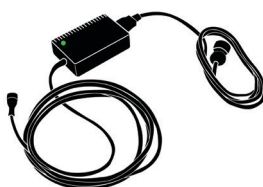

Figure 35



WARNING! ALWAYS connect an AC Adapter to the controller before relaxing or sleeping. Power from an electrical outlet (AC Adapter) provides power for an unlimited period of time.

2.4 HVAD® Controller Power Sources (continued)



WARNING! NEVER disconnect both power sources (batteries and AC or DC adapter) at the same time since this will stop the pump. At least one power source must be connected at all times.



For additional information on HeartWare® Batteries and AC/DC adapter, see Section 4.5

2.5 HeartWare® Battery Charger

The battery charger (**Figure 36**) is used to simultaneously recharge up to four batteries. It takes approximately 5 to 6 hours to fully charge a depleted battery. Each battery slides into a bay and is connected to the battery charger. It is safe to leave the batteries in the charger.



Figure 36



For additional information on the battery charger, see Section 4.4.

2.6 Carrying Cases and Shower Bag

The HeartWare® Waist Pack, HeartWare® Shoulder Pack, and HeartWare® Convertible Patient Pack are used to safely secure, store and carry the controller and batteries. They can be used in or out of the hospital, when resting, sleeping or ambulating. One controller and two batteries fit into each of the carrying cases.



CAUTION: The HeartWare® Waist Pack and the HeartWare® Shoulder Pack contain magnetic closures. Patients with an internal cardiac defibrillator (ICD) or pacemaker should keep the pack away from their chest, including when sleeping. Per pacemaker and ICD manufacturer guidelines, magnets should be kept at least 6 inches (15 centimeters) away from the pacemaker or ICD (please refer to manufacturer guidelines for additional information).

2.6 Carrying Cases and Shower Bag (continued)

HeartWare® Shower Bag

A shower bag is available for use in conjunction with the HeartWare™ HVAD™ System. To ensure safe and appropriate use of the shower bag, all patients and caregivers should be trained on shower bag operation prior to use.



WARNING! DO NOT allow patients to shower until they have received permission from their clinician to do so. Patients who shower must use the HeartWare® Shower Bag.

WARNING! DO NOT allow hearing impaired patients to shower unless their caregiver is close by to hear alarms.

WARNING! DO NOT plug the controller into an AC wall outlet during showers; to eliminate the possibility of a severe electrical shock, it should be connected to two batteries.

WARNING! DO NOT allow patients to take a bath or swim, as this may damage HeartWare™ HVAD™ System components and/or result in driveline exit site infection.

WARNING! DO NOT submerge HeartWare™ HVAD™ System components in water or other fluid as this may damage them. If this happens, contact HeartWare.

WARNING! DO NOT allow water or other fluids to enter the controller, power adapters, batteries, battery charger or connectors, as this may damage HeartWare™ HVAD™ System components. If this happens, contact HeartWare.

WARNING! DO NOT use any components other than those supplied by HeartWare with the HeartWare™ HVAD™ System, as this may affect HeartWare™ HVAD™ System operation.

WARNING! Damaged equipment should be reported to HeartWare and inspected.



CAUTION: DO NOT pull, kink or twist the driveline or the power cables, as these may damage the driveline. Special care should be taken not to twist the driveline while sitting, getting out of bed, adjusting controller or power sources, or when using the shower bag.

CAUTION: DO NOT attempt to repair or service any components of the HeartWare™ HVAD™ System. If HeartWare™ HVAD™ System equipment malfunctions, contact HeartWare.

+ 3.0 HeartWare™ HVAD™ System Pump

3.1 Principles of Operation.....67

3.2 Physiologic Control Algorithms69

3.2.1 Flow Estimation..... 69

3.2.2 [Ventricular Suction Detection] Alarm70

3.2.3 Lavare™ Cycle.....72

3.3 HVAD® Pump Operating Guidelines.....73

3.4 Expected Useful Life of the HVAD® Pump....73

3.5 Device Tracking and Reporting Requirements.....73

3.1 Principles of Operation

Background

The HVAD® Pump is a continuous flow pump. It contains a rotating impeller that adds energy to the blood by converting the rotational kinetic energy into mechanical energy (**Figure 37**). Impeller blades push the fluid through the pump using hydrodynamic and centrifugal forces. The net effect is to build up the fluid pressure, sometimes referred to as pump head (i.e., related to the differential pressure across the device) or just head, such that the fluid is moved from the inlet to the outlet of the pump. Pump head is the difference between the afterload and the preload. Energy to rotate the impeller is provided through electromagnetic coupling between permanent magnets (rotor magnet) attached or enclosed within the impeller and the motor stators. The motor stators consist of coils of wire that are sequentially charged by electrical current, turning the coils into electromagnets. These electromagnets have the effect of spinning the rotor magnets around an axis of rotation. The HVAD® Pump is efficient at pumping moderate quantities of blood against moderate amounts of resistance.

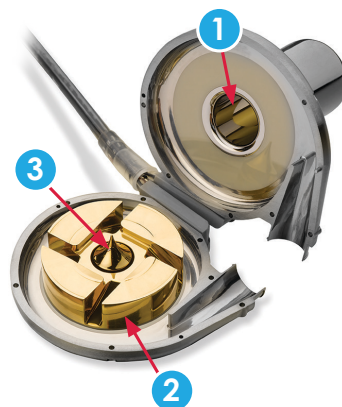

Figure 37: Open View of HVAD® Pump

- 1. Inflow Cannula
- 2. Impeller
- 3. Center Post

3.1 Principles of Operation (continued)

Blood Flow Characteristics

The amount of flow a rotary pump can generate is dependent upon the diameter of the impeller, the geometry of the impeller blades, housing design, motor capacity, rotational speed, and pressure differential that exists across the pump. This allows for in-vitro pump characterization for a specific pump and is the basis for blood flow estimation.

The HeartWare™ HVAD™ System estimates blood flow rate using HVAD® Pump characteristics (electrical current, impeller speed) and blood viscosity. Viscosity is calculated from the patient's hematocrit. To obtain the most accurate estimate of blood flow, the patient's hematocrit must be entered into the HeartWare® Monitor. Flow estimation should be used as a trending tool only, as it cannot adapt to changing fluid conditions.



For additional information on Flow Estimation, see Section 3.2.1.

The volume of flow generated by the HVAD® Pump is determined by the rotational speed of the impeller and by the pressure differential across the pump. The pressure that the HVAD® Pump must work against is similar to the mean arterial pressure. If the pump speed (RPM) is set too low then the device may not generate enough forward pressure. This can lead to retrograde flow (flow from the aorta back through the device and into the left ventricle). The maximum rotational speed is determined by how much flow is available from the right heart. If the speed is set too high and the pump attempts to pump more blood than is available, ventricular suction may occur.

The controller operates in “Fixed” mode, which maintains a constant motor speed. The motor speed range is between 1800 and 4000 RPM. The appropriate speed should be determined based on the patient condition.

NOTE: Recommended HVAD® Pump speeds are between 2400 RPM and 3200 RPM. HVAD® Pump speeds outside this range may result in less than optimal HVAD® Pump operation.

3.2 Physiologic Control Algorithms

The HVAD® Pump control algorithms provide clinicians information about device performance and HVAD® Pump blood flow estimation.

3.2.1 Flow Estimation

Estimated HVAD® Pump blood flow is calculated using VAD power, speed parameters, and hematocrit, based on a blood sample from the patient. The default hematocrit setting is 30%, but for accurate flow estimation, the patient's hematocrit should be entered into the monitor. Adjustments to the hematocrit setting on the monitor should be made for hematocrit changes of $\pm 5\%$ or greater.

NOTE: Update hematocrit settings on the monitor whenever hematocrit changes by plus or minus 5% or more.

The valid range of estimated blood flow is -2.0 to 10.0 L/min. The table below shows monitor and Controller Display messages and what they mean.

Table 27: Monitor and Controller Display Messages

Monitor and Controller Display	Estimated Flow Range
"_"	Invalid, not available
"< -2.0 L/min"	less than -2.0 L/min
"-2.0 L/min" up to "10.0 L/min"	-2.0 to 10.0 L/min
"> 10.0 L/min"	greater than 10.0 L/min

The error of the estimated flow is the maximum of either 1.0 L/min or 20%, whichever is greater. Flow estimation accuracy can be maintained only if accurate hematocrit values are entered.

Out of range values on the low side (less than -2.0 L/min), are invalid in terms of estimated flow but could indicate an incorrect hematocrit value used in the flow or occlusion of the inflow or outflow conduits. Out of range values on the high side (greater than 10.0 L/min), may occur due to thrombus or other materials (e.g. tissue fragments) in the device, due to an incorrect hematocrit value used in the flow or during an electrical fault.

NOTE: Flow estimation should only be used as a trending tool. Actual flow may differ from readout due to variability of patient's hematocrit.



WARNING! DO NOT rely only on flow estimation to assess cardiac output. An average estimated flow on the monitor or Controller Display of less than 2.0 L/min, or greater than 10.0 L/min may indicate an electrical fault, incorrect hematocrit entry or an occlusion and/or thrombus or other materials (e.g. tissue fragments) in the device. Inaccurate assessment of HVAD® Pump flow may lead to less than optimal treatment.

3.2 Physiologic Control Algorithms (continued)

3.2.2 [Ventricular Suction Detection] Alarm

A suction condition may occur due to ventricular collapse or inflow occlusion. Ventricular collapse occurs when a continuous flow VAD attempts to pump more blood from the left ventricle than is available, resulting in considerable reduction in ventricular volume. Left ventricular collapse can be the result of clinical events affecting left ventricular preload, including hypovolemia (bleeding), right heart failure, arrhythmia or pulmonary embolus. An inflow occlusion occurs when the inflow cannula is obstructed, causing a suction condition. Temporary inflow obstruction can occur as a result of surgical positioning, patient position or during straining (Valsalva).

The [Ventricular Suction Detection] alarm functions by monitoring the estimated flow for sudden decreases in flow rate. A flow baseline is established by continuously tracking the minimum flow values. A trigger value is established at 40% below the estimated flow baseline. An indication of suction is obtained when the minimum flow falls below this trigger level. The alarm will be triggered if this condition is maintained for 10 seconds.

The flow minimum that triggers the suction alarm is also used to define the suction clear limit. The estimated flow baseline is continuously compared to this limit. The suction alarm will be cleared if the flow baseline is maintained above the trigger level for 20 seconds. **(Figure 38)** This is an indication that the suction condition has cleared.

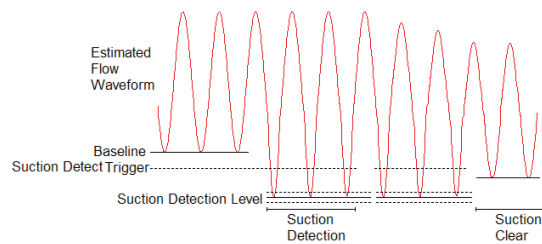

Figure 38

The [Ventricular Suction Detection] alarm can only be activated from the System Screen of the monitor. Therefore, only the clinician has access to control the state of this alarm. The default setting for Suction Response is “Off”. In this mode, there will be no alarm during a ventricular suction condition. An “Sx Off” message will be displayed on the lower left-hand corner of the monitor screen below the “Fixed” mode display. When Suction Response is enabled (via the “Alarm” button), the “Sx On” message will be displayed on the lower left-hand corner of the monitor screen below the “Fixed” mode display.



For additional information on the monitor, see Section 5.0.

NOTE: Whether or not the [Ventricular Suction Detection] alarm is enabled (“Sx On”) or is off (“Sx Off”) can only be determined with the monitor; it cannot be determined from the controller.

3.2 Physiologic Control Algorithms (continued)

3.2.2 [Ventricular Suction Detection] Alarm (continued)

The Suction Response “Alarm” mode must not be turned on if the patient is in a suction condition. If the mode is turned on during a suction condition, the “Sx On” message will be displayed on the monitor and the [Ventricular Suction Detection] alarm will be enabled but will be inaccurate due to the fact that normal baseline parameters could not be established during a suction condition. The algorithm attempts to establish a baseline detection level to distinguish abnormal conditions. This is not possible if the patient is experiencing ventricular suction when the algorithm is initiated. Once the suction condition clears, an accurate baseline will be obtained automatically and the suction detection will proceed.

NOTE: Ventricular suction detection may be activated once the patient's intravascular volume and pump flow have been stabilized.

If a [Ventricular Suction Detection] alarm is triggered, the clinician should evaluate whether the alarm was triggered by a transient, reversible condition which corrects itself, or whether the alarm is more serious and requires intervention. Transient alarms often occur at certain times during the day and/or under particular circumstances such as bending over or lying on one side. They usually resolve quickly without problems. If the [Ventricular Suction Detection] alarm is persistent and there are clinical symptoms of decreased blood flow, such as dizziness or hypotension, or if a [Low Flow] alarm is active, then the patient should be evaluated. This can be accomplished by checking the pump flow waveform on the monitor for evidence of suction, or if necessary, by visualizing the left ventricle with echocardiography. The clinician should attempt to identify and treat the underlying cause of the suction event. If the cause for the suction event cannot be determined, or if the cause is refractory to treatment, then the clinician should manually adjust the speed to resolve the suction condition. Manual changes to the speed will immediately disable the [Ventricular Suction Detection] alarm. An “Sx Off” will be displayed on the monitor screen below the “Fixed” Mode display. The clinician will have to reactivate the alarm after adjusting the speed.



CAUTION: Manual changes to the speed will immediately disable the [Ventricular Suction Detection] alarm. An “Sx Off” will be displayed on the monitor screen below the “Fixed” mode display. The [Ventricular Suction Detection] alarm will have to be re-activated.

CAUTION: DO NOT enable the [Ventricular Suction Detection] alarm while the patient is in a suction condition. To optimize operation of the suction detection the patient should be hemodynamically stable prior to enabling the [Ventricular Suction Detection] alarm.

3.2 Physiologic Control Algorithms (continued)

3.2.2 [Ventricular Suction Detection] Alarm (continued)

The ventricular suction detection function will temporarily deactivate if:

- The estimated flow value becomes invalid. Once the flow estimation is within valid range, the ventricular suction detection will resume.
- The baseline flow value is less than 1.8 L/min – the algorithm loses sensitivity if the baseline and, therefore, the suction detection level gets too low. Once the baseline value is above 1.8 L/min, then the ventricular suction detection will resume.
- The clinician changes the hematocrit input – the algorithm recognizes that a change in the fluid viscosity will cause a change in the estimated flow. The ventricular suction detection reactivates once a new baseline is established.
- Lavare™ Cycle is active – the Lavare™ Cycle has a direct impact on the Suction Alarm tracking parameters, so the algorithm is temporarily disabled. The ventricular suction detection re-activates with the previous baseline once the Lavare™ Cycle is completed.

3.2.3 Lavare™ Cycle

The Lavare™ Cycle is a speed modulation algorithm designed to reduce areas of potential blood stasis within the left ventricle. As depicted in **Figure 39**, the Lavare™ Cycle decreases the pump speed by 200 RPM below the set speed for 2 seconds then increases the pump speed to 200 RPM above the set speed for 1 second followed by the return to the original set speed for 60 seconds. Once activated the Lavare™ Cycle continues until deactivated.

Figure 39: Lavare™ Cycle Example: full cycle (left), close up of speed modulation (right)

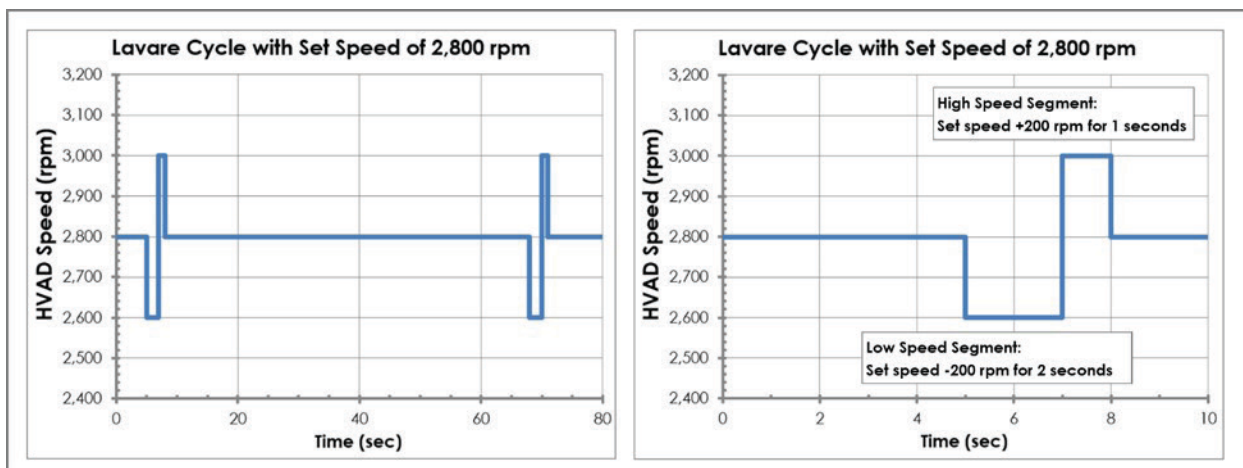

Lavare™ Cycle is limited by pump speed range of 1800 – 4000 RPM during the low and high speed portions of the cycles. Accounting for the ± 200 RPM change with respect to the set speed during the Lavare™ Cycle, set speeds below 2000 or above 3800 will not allow for the full ± 200 RPM change. For example, if the set speed is 1900 RPM, the Lavare™ Cycle will operate between 1800 RPM and 2100 RPM, instead of 1700 RPM and 2100 RPM.

3.2 Physiologic Control Algorithms (continued)

3.2.3 Lavare™ Cycle (continued)

The Lavare™ Cycle has two settings, OFF and ON which can be set by the clinician via the HeartWare® Monitor. It is recommended that the Lavare™ Cycle be initiated once the patient is hemodynamically stable and it is confirmed that the patient can tolerate the 2 seconds of reduced support.

Hemodynamically Stable Suggests:

- HVAD® Pump flow is maintained within the targeted range for each patient.
- The patient's intravascular volume is stable requiring no serial blood product transfusions (no active bleeding).
- Inotropic, vasoactive and anti-arrhythmic drugs are at constant dosages or being decreased.

It is recommended that the "Lavare Cycle" be deactivated if use of the Lavare™ Cycle has a detrimental effect on the patient such as increased suction events or [Low Flow] alarms.

NOTE: If thrombus is suspected within the device, the Lavare™ Cycle should be turned "Off" until the thrombus is resolved.

3.3 HVAD® Pump Operating Guidelines

The HVAD® Pump speed can be set between 1800 and 4000 RPM, however the recommended clinical operating speed range is 2400 to 3200 RPM. Speeds below 2400 RPM should only be used during the implant procedure when weaning from cardiopulmonary bypass. Speeds above 3200 RPM are seldom needed and may increase the risk of suction events. HVAD® Pump power ranges from 2.5 to 8.5 Watts when operating within the recommended speed range. Power values > 8.5 Watts suggests a problem which should be evaluated by log file analysis. The table below shows the expected average values for speed, power and flow at 2400 and 3200 RPMs.

Table 28: Expected Average HVAD® Pump Parameters

Speed (RPMs)	Power (Watts)	Flow (L/min)
2400	2.5	3.0
3200	8.5	8.0

3.4 Expected Useful Life of the HVAD® Pump

The HVAD® Pump was designed and tested to function for two years.

3.5 Device Tracking and Reporting Requirements

The HVAD® Pump is considered a life-sustaining medical device and must be tracked per US Food and Drug Administration (FDA) and other foreign regulatory agency regulations. Compliance is mandatory. Accordingly, all device tracking paperwork must be completed and promptly returned to HeartWare. In addition, any device malfunctions must be reported to HeartWare by the implanting center.

+ 4.0 HeartWare™ HVAD™ System Peripherals and Accessories

- 4.1 HVAD® Controller Connections75
- 4.2 HVAD® Controller.....79
- 4.3 Using the HeartWare® Batteries83
- 4.4 Using the HeartWare® Battery Charger89
- 4.5 Using the HVAD® Controller AC Adapter or DC Adapter92
- 4.6 Carrying Cases.....93
- 4.7 Recommended Equipment for Use at Home.....94

4.1 HVAD® Controller Connections

Controller Connector Layout

There are four ports on the controller (Figure 40)

Data Cable Connection

- Usually covered with a dust cap
- Accepts the data cable from the monitor or the red alarm adapter with the blue ring

Driveline Connection

- Connects the pump driveline to the controller
- Should never be removed unless performing a controller exchange

Figure 40

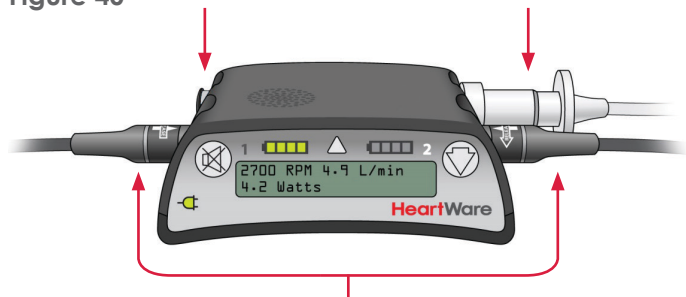

Power Connection

- Connects the controller to the power source
- Accepts battery, AC, or DC adapter power
- Never disconnect both power sources at the same time or the pump will stop



CAUTION: ALWAYS keep all connectors free of liquid, dust and dirt, or the HeartWare™ HVAD™ System may not function as intended.

4.1 HVAD® Controller Connections (continued)

Driveline Connection to the Controller:

To Disconnect the Driveline from the Controller:

1. Slide the driveline cover away from the controller so you can see the whole silver connector.



Figure 41

2. Place your fingers on the silver connector, over the ringed area.



Figure 42

3. Pull back on the ringed area to release the locking mechanism.

Note: if you pull back on any other area of the driveline or connector it will not release the driveline from the controller.



Figure 43

To Connect the Driveline:

1. Line up the red dots on the driveline connector and on the controller driveline port.



Figure 44

2. Push the driveline connector straight into the port.

Note: Verify the pump is running to ensure proper connection.



Figure 45

3. Slide the driveline cover over the driveline connector.



Figure 46



WARNING! DO NOT grasp the driveline cable as this may damage the driveline. To remove the driveline from the controller, first pull back the driveline cover then grasp and pull the driveline connector.

WARNING! DO NOT disconnect the driveline from the controller or the pump will stop. If this happens, reconnect the driveline to the controller as soon as possible to restart the pump.

4.1 HVAD® Controller Connections (continued)

Connecting Power Sources and Monitor Cable to the Controller:

To Connect a Power Source:

1. To connect all power supplies (battery, AC adapter or DC adapter) grasp the power cable near its connector. Leave the connector free to rotate.



Figure 47

2. Line up the solid white arrow on the cable connector with the dot on the controller (Figure 48).



Figure 48

3. Gently push the cable into the controller. DO NOT twist the connector, but allow it to naturally lock in place. A good connection will result in an audible click.

NOTE: When pushing the connector into the controller the white arrow will shift slightly into the correct locking position.



Figure 49

4. Confirm that the power cable is properly locked to the controller by gently pulling on the cable near the connector. Repeat steps above for second power source.



CAUTION: DO NOT force connectors together without proper alignment. Forcing together misaligned connectors may damage the connectors.

CAUTION: ALWAYS confirm that the power cables are properly locked on the controller by gently pulling the cable near the controller power connector or the power cables may come loose and result in an alarm or the pump stopping.

4.1 HVAD® Controller Connections (continued)

Disconnecting Power Sources:

Disconnecting from the AC Adapter or DC Adapter

Before switching from AC or DC power to battery power, make sure that a fully charged battery is available. Connect the fully charged battery after disconnecting the AC or DC adapter. To disconnect power cables from the controller:

1. Turn the connector counterclockwise until it stops.

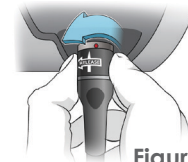

Figure 50

2. Pull the connector straight out from the controller.

NOTE: If another power source is not connected within 20 seconds, the [Power Disconnect] message will be displayed on the Controller Display and an alarm will sound.

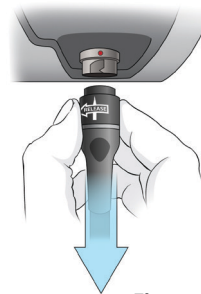

Figure 51

NOTE: The alarm will automatically clear when another power source is connected to the controller.

3. Connect a fully charged battery to the controller power connector.
4. If a charged battery is not connected to the controller within 20 seconds, the [Power Disconnect] message will be displayed on the Controller Display and an alarm will sound.

4.2 HVAD® Controller



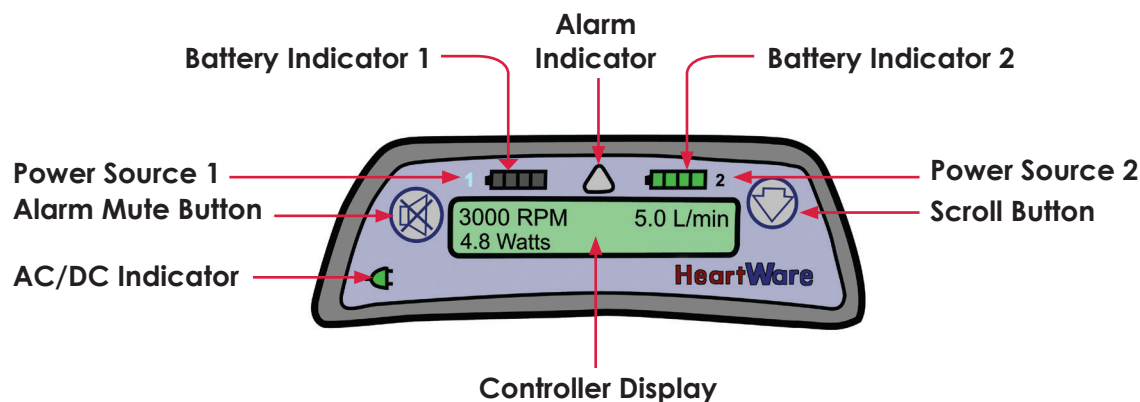

WARNING! DO NOT operate the controller in temperatures less than -20°C (-4°F) or greater than +50°C (+122°F) or the controller may fail.

Figure 52: The controller face incorporates a number of visual indicators and function buttons.





Controller Settings Menu

The Controller Settings Menu may be used to view controller information when a monitor is not available.

- To access the menu press and hold  for two (2) seconds and then release.
- Press  again to navigate through the controller settings. After the last setting in the menu, navigation will return to the top of the Settings Menu.

The controller will exit the settings menu automatically after 60 seconds.







- To exit the settings menu manually, press and hold  for two (2) seconds.
- Once a user reaches the end of the menu, the next  press will return to the Home screen on the Controller Display.

The Controller Settings Menu includes the following information:

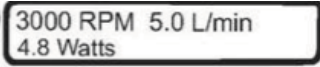
- | | |
|---------------------------------|---------------------------------|
| 1. Battery Cycles | 8. Peak Flow (L/min) |
| 2. [Low Flow] alarm (Setting) | 9. Trough Flow |
| 3. [High Power] alarm (Setting) | 10. Implant Date |
| 4. Hematocrit (Setting) | 11. Controller Date |
| 5. RPM Setting | 12. VAD ID |
| 6. Suction Response (On/Off) | 13. Patient ID |
| 7. "Lavare Cycle", if enabled | 14. Controller Software Version |

4.2 HVAD® Controller (continued)

Table 29: Guide to Controller Display, Buttons, and Indicators

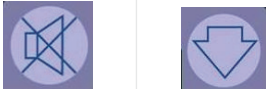
	<p>The CONTROLLER DISPLAY gives pump information including impeller speed (RPM), power (Watts), and blood flow (L/min). When an alarm occurs, the pump information is replaced by two lines of text that tell you what the alarm is and what to do. The Controller Display also provides additional pump information in the controller settings menu.</p> <p>i For additional information on alarms, see Section 8.1.</p>
	<p>The AC/DC INDICATOR will be green if you are using the AC adapter or DC adapter to power the controller.</p>
	<p>The two BATTERY INDICATORS located on the top of the controller are labeled "1" and "2". Either the "1" or "2" will be lit, depending upon which port is providing primary power. If an AC or DC adapter is connected, this will be the primary power source. The Battery Indicators tell you approximately how much power remains in each battery.</p> <p>Note: If the AC adapter or DC adapter is connected to the controller, the corresponding Battery Indicator will not display lights but the corresponding "1" or "2" will be lit.</p>
	<p>The ALARM INDICATOR lights when one or more alarms occur. The Alarm Indicator changes colors depending on the severity of the alarm and always displays the most severe alarm in the case of multiple alarms.</p> <p>i For additional information on alarms, see Section 8.1.</p>
	<p>The "ALARM MUTE" button will silence (mute) a low or medium alarm for 5 minutes or until a new alarm occurs. A high alarm cannot be silenced. Follow the instructions on the display screen, including to call your clinician for all medium and high alarms.</p>
	<p>The "SCROLL" button on the right side of the controller has 4 functions:</p> <ol style="list-style-type: none"> 1. used to see all active alarms as well as pump information (RPM, L/min, Watts) on the Controller Display. 2. will clear resolved medium alarms from the Controller Display. 3. will brighten the Controller Display. 4. will show additional information if pressed and held for 2 seconds.
	<p>Pressing and holding the "ALARM MUTE" button and the "SCROLL" button for 5 seconds at the same time will prevent the [No Power] alarm from sounding when power is removed during a controller exchange (use only on a controller not connected to a pump).</p> <p>i For additional information on changing controllers, see Section 8.7.</p>

4.2 HVAD® Controller (continued)

Electrostatic Discharge (ESD)

Static electricity is widely present and more so in certain conditions such as in drier environments and in the vicinity of certain materials and fabrics such as silk clothing and carpeting. Discharge of static electricity, commonly referred to as electrostatic discharge (ESD), may interfere with electronic equipment. The HVAD® Controller, as a piece of electronic equipment, is susceptible to ESD. Be aware of ESD and its potential to cause disruptive and possibly fatal faults in susceptible patients.

The controller may alarm in certain situations as a result of ESD. These alarms include:

1. A [Controller Failed] alarm.
2. A high audible alarm without accompanying alarm text on the Controller Display.
 - If either of those alarms occur: The controller should be switched to the back-up controller.
3. A [Controller Fault] alarm.
 - If that alarm occurs: It should be treated as directed in Section 8.3 (“Medium Priority Alarms”), since there are a number of potential causes for this alarm.



WARNING! AVOID devices and conditions that may induce strong static discharges (e.g., television or computer monitor screens) as electrostatic discharges can damage the electrical parts of the system and cause the LVAD to perform improperly or stop.

WARNING! The HeartWare™ HVAD™ System components should not be used adjacent to or stacked with equipment other than specified in the IFU. If adjacent to or stacked use is necessary, the HeartWare™ HVAD™ System and other equipment should be observed to verify normal operation.

WARNING! ALWAYS have a back-up controller handy and, whenever possible, a caregiver nearby when changing power sources or controllers. Be watchful for unusual changes in power or flow alarms for a period of time following equipment changes.



In order to avoid or minimize the potential for ESD occurrence, follow good power/battery connection techniques as described in the IFU and patient manual.

To reduce the chance of ESD damage to the controller instruct patients to:

1. Make good connections when changing power sources
 - Do not touch the controller connector ports, or let foreign objects or materials come near a disconnected controller power port.
 - Have new battery within reach before disconnecting power source and when possible, have a caregiver nearby in case an alarm occurs.
 - Use 2 power sources. Only leave power source ports on controller open for the time it takes to change the power sources.
2. Be careful near materials and electronic devices prone to static electricity, such as: carpeted floors, silk clothing, TV screens, microwaves when in operation, and laptop or computer screens.
 - Avoid changing power sources in these areas.
 - Avoid vacuuming and removing clothes from the dryer.
 - Use anti-static dryer sheets and fabric softener.
 - Consider humidifier in your house.

4.2 HVAD® Controller (continued)

In patients who may be at risk of catastrophic cardiovascular collapse associated with a pump shutdown (fused aortic valve, aortic valve that has been sewn shut due to aortic valve regurgitation, or patients with very poor endogenous ventricular function) ESD education is extremely important and controller exchanges should be performed in a controlled clinical setting whenever possible.

Controller Care

Once a week: Instruct the patient to inspect the controller power connections and connector pins for dirt. This inspection can be done while the patient is changing batteries or when changing from batteries to the AC adapter. Check the power connections on the controller one at a time. DO NOT disconnect both power sources to examine the connections. DO NOT disconnect the pump to examine the percutaneous lead/controller connection. This connector should be inspected only during a controller exchange. The patient should not attempt to clean the controller connectors, but should be instructed to contact their VAD coordinator if they notice the connectors are dirty. Exterior surfaces of the controller should be cleaned using a clean cloth. A damp cloth may be used but a wet cloth should not.

Periodically or as needed:

The **controller** may be cleaned with the following agents:

- Alcohol (Isopropyl 90% or Ethyl 70%)
- Hydrogen peroxide solution (1.4%)
- n-Alkyl Dimethyl Dibenzyl Ammonium Chloride combined with n-Alkyl Dimethyl Ethylbenzyl Ammonium Chloride (active agent in some disinfecting wipes).
- Silver, ethanol, acetic acid, peroxyacetic acid, hydrogen peroxide solution (active ingredients of some sporicidal disinfecting wipes)
- UV-C disinfecting wand, one that radiates "short wave" UV-C band rays (100 to 280 nanometers) from a 4 watt bulb (or stronger)

Expected Useful Life of the HVAD® Controller

The HVAD® Controller was designed and tested to function for two years.



WARNING! DO NOT drop the controller or other equipment. Dropping the controller could cause sudden stoppage of the pump. Dropped equipment should be reported to HeartWare and inspected.

WARNING! DO NOT disconnect the driveline or power sources from the controller while cleaning it or the pump will stop. If this happens, reconnect the driveline to the controller as soon as possible to restart the pump.

4.3 Using the HeartWare® Batteries

The batteries contain lithium ion cells to power the HVAD® Pump for approximately 4 to 7 hours when fully charged. When connected to the controller, the battery will communicate battery capacity and other parameters to the controller. The capacity (hours of support) of each battery is based on:

- Controller and HVAD® Pump operating power consumption
- Number of battery charge and discharge cycles

Only fully charged batteries should be connected to the controller. There are two ways to know if the battery is fully charged and ready for use:

1. The battery test button
2. The battery charger



For additional information on battery charging, see Section 4.4.

On the battery, press the test button to light up the battery capacity display.

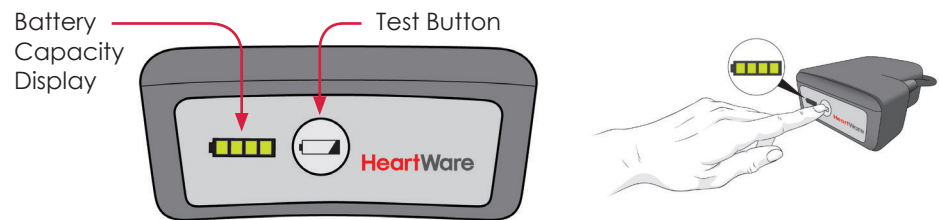

Figure 53: Battery

The battery capacity display (**Figure 53**) will light up showing how much power is in each battery. See **Table 30**.



For additional information on using the HVAD® Controller, see Section 4.2.

Table 30: Battery Capacity

Battery Capacity	Battery Capacity Display
75-100%	4 GREEN lights
50-74%	3 GREEN lights
25-49%	2 GREEN lights
less than 25%	1 GREEN light

4.3 Using the HeartWare® Batteries (continued)

The controller will provide 3 indications for when to change a battery:

1. Battery indicator will show 1 yellow light.
2. Alarm indicator will be solid yellow.
3. Display will read [Low Battery] [Replace Battery].

Figure 54: Replace Depleted Battery Message on Controller

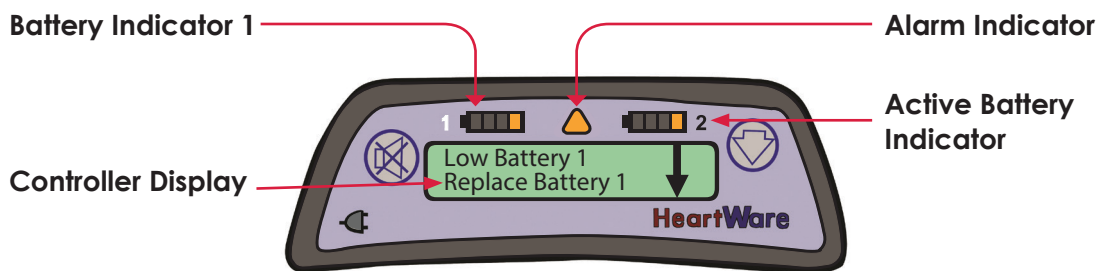

If a depleted battery is not exchanged, eventually a high priority alarm will sound, the Alarm Indicator will be flashing RED and the message on the Controller Display will read [Critical Battery]. A charged battery or adapter (AC or DC) should be attached immediately to the power port with the critical battery indication. Never disconnect both power sources at one time.



WARNING! NEVER disconnect both power sources (batteries and AC or DC adapter) at the same time since this will stop the pump. At least one power source must be connected at all times.

WARNING! ALWAYS keep a spare controller and fully-charged spare batteries available at all times in case of an emergency.



CAUTION: ALWAYS recharge fully depleted batteries within 24 hours to avoid permanent battery damage.

4.3 Using the HeartWare® Batteries (continued)

Table 31: Controller Battery Indicators

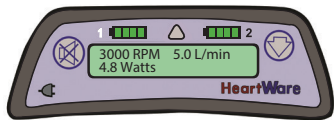
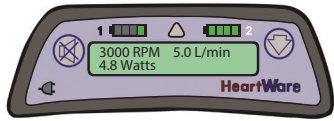
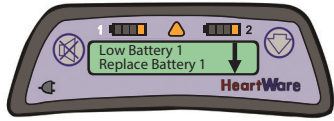
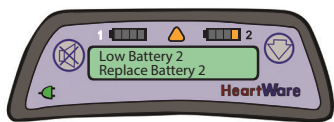
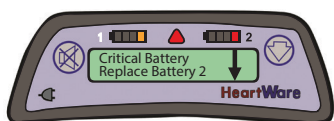
If your controller shows:	It means:	You:
	You have 2 fully charged batteries connected to your controller. In this example, the battery connected to Power Source 1 is providing primary power.	Do not need to change either battery.
	The battery connected to Power Source 1 has less than 25% capacity. In this example, the battery connected to Power Source 2 is fully charged and providing primary power.	Do not need to change either battery.
	Both batteries connected to your controller have less than 25% capacity. In this example, the battery connected to Power Source 1 is providing primary power. The down arrow indicates there is another alarm.	Should attach a full battery or AC adapter to Power Source 1.
	The battery connected to Power Source 2 has less than 25% capacity. In this example, an AC or DC adapter is connected to Power Source 1 and is providing primary power.	Should connect a fully charged battery to Power Source 2.
	The battery connected to Power Source 2 has limited time remaining. The battery connected to Power Source 1 has less than 25% capacity and is providing primary power.	Should attach a full battery or AC or DC adapter to Power Source 2. Then, attach a full battery or AC or DC adapter to Power Source 1. Never disconnect both batteries at the same time. This will stop your pump.
The controllers shown above are meant to be examples of the changes you might see during the day.		

4.3 Using the HeartWare® Batteries (continued)



WARNING! ALWAYS keep a spare controller and fully-charged spare batteries available at all times in case of an emergency.



HeartWare™ HVAD™ System Power Management Guide is available from your clinician.

Care of Batteries

1. To preserve battery life, batteries should be stored at room temperature.
2. Protect batteries from extreme high and low temperatures. Avoid storage in direct sunlight.
3. Protect the battery connectors from moisture, dirt and metal at all times.
4. Handle connectors so as to avoid touching the inside.
5. Do not drop the batteries or let them hit hard objects.
6. Do not let batteries get wet.
7. Do not twist or kink battery cables.
8. Do not force battery connection to the controller or battery charger.
9. Batteries should be stored in the battery charger. Store batteries fully charged.
10. Rotating use of batteries will allow all batteries to age at a similar rate so no battery has significantly fewer charge cycles than the others.

4.3 Using the HeartWare® Batteries (continued)



CAUTION: DO NOT expose batteries to temperatures outside the storage and operational ranges or they may provide less support than usual. To preserve battery life, batteries should be stored at room temperature.

Battery operating and storage temperatures:

- a. Operating: discharge (normal use with the HeartWare™ HVAD™ System): 0°C to +50°C (+32°F to +122°F). Operation at temperatures below 0°C will temporarily reduce battery capacity but the battery will operate.
- b. Storage: -20°C to +25°C (-4°F to +77°F). Long term storage outside of this range may permanently reduce the battery capacity. Best condition for storage is at room temperature.

CAUTION: ALWAYS keep batteries away from children. Children may be harmed by damaged batteries or components.

CAUTION: DO NOT disassemble, crush, or puncture a battery.

CAUTION: DO NOT use a damaged battery. Battery function is unknown if the battery is damaged.

CAUTION: DO NOT short circuit the external contacts on a battery since this may result in battery damage.

CAUTION: DO NOT touch the fluid if a battery pack is leaking fluid. Dispose of a leaking battery pack. In case of eye contact with fluid, DO NOT rub eyes. Immediately flush eyes thoroughly with water for at least 15 minutes, lifting upper and lower lids, until no evidence of the fluid remains. Seek medical attention.

CAUTION: DO NOT expose batteries to excessive shock or vibration since this may affect battery operation.

CAUTION: DO NOT dispose of a battery in fire or water. Dispose of batteries according to federal, state, and local regulations.

Once a week: Inspect batteries for physical damage, including the battery cable and connectors for damage. DO NOT use batteries that appear damaged. Damaged batteries must be replaced.

Periodically or as needed:

- Exterior surfaces of the batteries should be cleaned using a clean cloth. A damp cloth may be used but a wet cloth should not.
- Remind patients to bring all batteries to clinic visits.



CAUTION: DO NOT place batteries in water or liquid.

NOTE: The HeartWare® Batteries components were designed and tested to function for the following periods: As consumable items they are expected to have a useful operating life of 500 charge and discharge cycles; this should provide patient support for one year. Batteries that reach the end of their useful life should be taken out of service. If a battery provides less than 2 hours of support duration, it should be taken out of service.

4.3 Using the HeartWare® Batteries (continued)

The Batteries may be cleaned with the following agents:

- Alcohol (Isopropyl 90% or Ethyl 70%).
- Hydrogen peroxide solution (1.4%).
- n-Alkyl Dimethyl Dibenzyl Ammonium Chloride combined with n-Alkyl Dimethyl Ethylbenzyl Ammonium Chloride (active agent in some disinfecting wipes).
- Silver, ethanol, acetic acid, peroxyacetic acid, hydrogen peroxide solution (active ingredients of some sporicidal disinfecting wipes).
- UV-C disinfecting wand, one that radiates “short wave” UV-C band rays (100 to 280 nanometers) from a 4 watt bulb (or stronger).

Expected Useful Life of HeartWare® Batteries

The HeartWare® Batteries components were designed and tested to function for the following periods:

As consumable items they are expected to have a useful operating life of 500 charge and discharge cycles; this should provide patient support for one year. Batteries that reach the end of their useful life should be taken out of service. If a battery provides less than 2 hours of support duration, it should be taken out of service.

Product Disposal

Specific product disposal considerations for certain HeartWare-supplied equipment appears below. Otherwise, dispose of all expired or damaged equipment according to applicable local, state, and federal laws and regulations. For additional product disposal support and information, contact HeartWare.

HeartWare Li-Ion battery cells DO NOT contain lead. Dispose of/recycle HeartWare® Batteries in compliance with all applicable local, state, and federal laws and regulations. DO NOT incinerate.

4.4 Using the HeartWare® Battery Charger

To Set up Your Battery Charger:

1. Insert the power cable into the back of the charger.

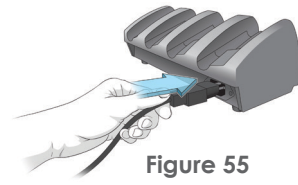

Figure 55

2. Plug the other end of the cable into a wall outlet.

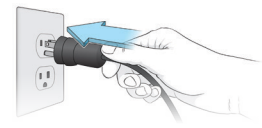

Figure 56

3. Once the charger is connected to power, the green power light, located on the front bottom right side of the charger will be on.



Figure 57

When a battery is connected, the battery charger checks the battery and begins charging. To connect a battery to the charger, follow the steps below:

1. Connect the battery to the power port located under each slot, the same way you connect a battery to the controller.

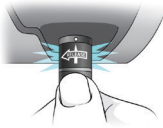

Figure 58

2. Place the battery into the slot. For the best fit, loop the cable gently to the side and place the battery with the cable-side down.

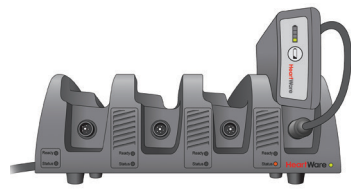
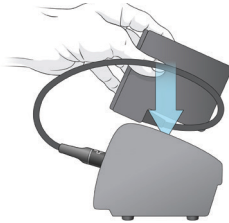

Figure 59

3. Repeat steps 1 and 2 for all batteries. The charger can hold up to 4 batteries at one time.



Figure 60

4.4 Using the HeartWare® Battery Charger (continued)

Each battery charging slot has two lights that tell you the status of the battery. A green light next to “Ready” means the battery is fully charged. The light next to “Status” may mean different things, depending upon the color. The table below describes the lights that appear next to “Status”.

The charger has two indicators for each charging bay. The indicators are “Ready” and “Status.” The green light adjacent to the “Ready” indicates that the battery is fully charged (**Figure 61**).

Figure 61: Battery Charger Indicators

1. “Ready”
2. “Status”
3. AC Power

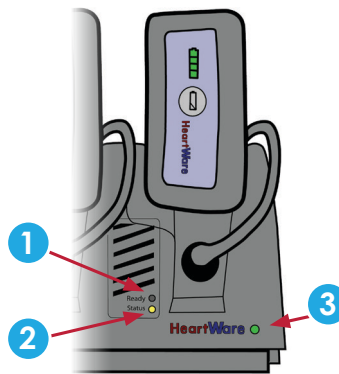

Table 32: Battery Charger “Status” Lights

Battery Charger “Status” Light	What it Means
Yellow	Battery being charged; NOT ready for use.
Flashing Yellow	Battery not charging. Check battery connections. If connections are intact, switch to another battery slot. If problem persists, return battery to Clinician.
Red	Battery too cold or too hot; waiting to charge.
Flashing Red	Defective battery. Do NOT use. Mark battery and return to Clinician.



CAUTION: ONLY use the HeartWare® Battery Charger to charge HeartWare® Batteries. Other battery chargers will not charge the batteries and may damage them.

CAUTION: ALWAYS wait until the “Ready” light turns on to disconnect the battery from the battery charger. If this is not followed over consecutive charging cycles, the Battery Capacity Display will not function properly and may convey misleading battery capacity.

4.4 Using the HeartWare® Battery Charger (continued)

Care of the Battery Charger

Once a week:

- Inspect the battery charger for signs of physical damage, such as dents, chips, or cracks. DO NOT use the charger if it shows signs of damage. Contact HeartWare for a replacement.
- Inspect the power cord used to connect the charger to an electrical outlet. Make sure the cord is not kinked, split, cut, cracked, or frayed. Do not use the cord if it shows signs of damage. Contact HeartWare for a replacement.

Periodically or as needed: To clean the battery charger, remove the batteries and unplug the charger from the electrical outlet. Clean the exterior surface of the charger using a clean, dry cloth. DO NOT place the charger in water or liquid.



WARNING! NEVER clean the battery charger with the power on, as this may lead to an electrical shock.

The Battery Charger may be cleaned with the following agents:

- Alcohol (Isopropyl 90% or Ethyl 70%).
- Hydrogen peroxide solution (1.4%).
- n-Alkyl Dimethyl Dibenzyl Ammonium Chloride combined with n-Alkyl Dimethyl Ethylbenzyl Ammonium Chloride (active agent in some disinfecting wipes).
- Silver, ethanol, acetic acid, peroxyacetic acid, hydrogen peroxide solution (active ingredients of some sporicidal disinfecting wipes).
- UV-C disinfecting wand, one that radiates “short wave” UV-C band rays (100 to 280 nanometers) from a 4 watt bulb (or stronger).

Expected Useful Life of HeartWare® Battery Charger

The battery charger was designed and tested to function for one year.

4.5 Using the HVAD® Controller AC Adapter or DC Adapter

The AC adapter (**Figure 62**) has cables that connect to the controller and into an electrical outlet. Prior to connection to the controller, verify proper connection of the power cord to the adapter (**Figure 63**) and electrical outlet. If not properly connected, perform the following steps:

1. Using a Philips screw driver, loosen the screw at the retainer clip to allow the retainer clip to open.
2. Insert the AC power cord completely and securely into the receptacle of the AC adapter.
3. Tighten the screw at the retainer clip closing the retainer clip.
4. Ensure that AC power cord is secure in the adapter receptacle and cannot be pulled out.

A green indicator light on the adapter will indicate proper connection. Ensure that the power indicator on the power adapter cable turns green before plugging into the controller.

Figure 62

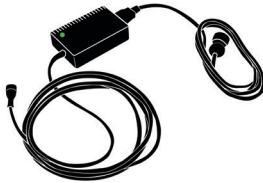

Figure 63



Figure 64



The DC adapter (**Figure 64**) plugs into the power port located in most cars. When the DC adapter is properly connected to power, a green indicator light will be displayed on the adapter.

NOTE: The DC adapter is for use in vehicles only and may not fit in some vehicles.

Care of Adapters

The AC power adapter may be cleaned with the following agents:

- Alcohol (Isopropyl 90% or Ethyl 70%).
- Hydrogen peroxide solution (1.4%).
- n-Alkyl Dimethyl Dibenzyl Ammonium Chloride combined with n-Alkyl Dimethyl Ethylbenzyl Ammonium Chloride (active agent in some disinfecting wipes).
- Silver, ethanol, acetic acid, peroxyacetic acid, hydrogen peroxide solution (active ingredients of some sporicidal disinfecting wipes).
- UV-C disinfecting wand, one that radiates "short wave" UV-C band rays (100 to 280 nanometers) from a 4 watt bulb (or stronger).

The controller DC power adapter may be cleaned with the following agents:

- Alcohol (Isopropyl 90% or Ethyl 70%).
- n-Alkyl Dimethyl Dibenzyl Ammonium Chloride combined with n-Alkyl Dimethyl Ethylbenzyl Ammonium Chloride (active agent in some disinfecting wipes).
- Silver, ethanol, acetic acid, peroxyacetic acid, hydrogen peroxide solution (active ingredients of some sporicidal disinfecting wipes).
- UV-C disinfecting wand, one that radiates "short wave" UV-C band rays (100 to 280 nanometers) from a 4 watt bulb (or stronger).

4.6 Carrying Cases

The HeartWare® Waist Pack, HeartWare® Shoulder Pack, and HeartWare® Convertible Patient Pack are used to safely secure, store and carry the controller and batteries. They can be used in or out of the hospital, when resting, sleeping or ambulating. One controller and two batteries fit into each of the carrying cases.



CAUTION: The HeartWare® Waist Pack and the HeartWare® Shoulder Pack contain magnetic closures. Patients with an internal cardiac defibrillator (ICD) or pacemaker should keep the pack away from their chest, including when sleeping. Per pacemaker and ICD manufacturer guidelines, magnets should be kept at least 6 inches (15 centimeters) away from the pacemaker or ICD (please refer to manufacturer guidelines for additional information).

HeartWare® Shower Bag

A shower bag is available for use in conjunction with the HeartWare™ HVAD™ System. To ensure safe and appropriate use of the shower bag, all patients and caregivers should be trained on shower bag operation prior to use.



WARNING! DO NOT allow patients to shower until they have received permission from their clinician to do so. Patients who shower must use the HeartWare® Shower Bag.

WARNING! DO NOT allow hearing impaired patients to shower unless their caregiver is close by to hear alarms.

WARNING! DO NOT plug the controller into an AC wall outlet during showers; to eliminate the possibility of a severe electrical shock, it should be connected to two batteries.

WARNING! DO NOT allow patients to take a bath or swim, as this may damage HeartWare™ HVAD™ System components and/or result in driveline exit site infection.

WARNING! DO NOT submerge HeartWare™ HVAD™ System components in water or other fluid as this may damage them. If this happens, contact HeartWare.

WARNING! DO NOT allow water or other fluids to enter the controller, power adapters, batteries, battery charger or connectors, as this may damage HeartWare™ HVAD™ System components. If this happens, contact HeartWare.



CAUTION: DO NOT pull, kink or twist the driveline or the power cables, as these may damage the driveline. Special care should be taken not to twist the driveline while sitting, getting out of bed, adjusting controller or power sources, or when using the shower bag.

4.7 Recommended Equipment for Use at Home

Patients with the HeartWare™ HVAD™ System should have this equipment close to them and readily available at all times (when in the hospital, at home, or when traveling overnight).

2 Controllers with AC adapters

1 Battery charger

4 Batteries

1 DC adapter

1 Driveline cover

2 Alarm adapters

1 Shower bag

1 or more carrying cases (Shoulder Pack, Waist Pack or Convertible Patient Pack)

Whenever patients with the HeartWare™ HVAD™ System leave their house on a short trip such as running errands, in addition to what they are currently using, they should bring the following equipment as backup:

1 Controller

2-3 Charged batteries

Emergency contact information

1 AC adapter

1 Alarm adapter



WARNING! AVOID areas with high magnetic forces such as theft detection devices or airport security systems, as this may affect HeartWare™ HVAD™ System operation.

WARNING! Keep mobile phones at least 20 inches (50 centimeters) away from the controller, as mobile phones may interfere with controller operation.

WARNING! DO NOT let the patient have a magnetic resonance imaging (MRI) procedure while implanted with the HVAD® Pump. Doing so could cause harm to the patient or could cause the pump to stop.

WARNING! DO NOT apply high power electrical treatment (e.g., deep tissue heating which can be used for treatment of arthritis and/or some injuries) directly to the patient, as this may affect HeartWare™ HVAD™ System operation.

WARNING! AVOID therapeutic levels of ultrasound energy, as the device may inadvertently concentrate the ultrasound field and cause harm.

WARNING! AVOID therapeutic ionizing radiation since it may damage the device. This damage may not be immediately detectable.

WARNING! The HeartWare™ HVAD™ System components should not be used adjacent to or stacked with equipment other than specified in the IFU. If adjacent to or stacked use is necessary, the HeartWare™ HVAD™ System and other equipment should be observed to verify normal operation.

+ 5.0 Using the HeartWare® Monitor

All HeartWare® Monitors are compatible with all HVAD® Controller software versions. The operating system software in monitor REF1510 cannot be updated and as a result, use of the REF1510 may limit access to certain features.

5.1 General Overview95

5.2 Informational Screens97

5.3 System Screens.....99

5.4 Downloading Controller Log Files.....110

5.5 Updating Software on the HVAD® Controller.....111

5.6 Monitor Shutdown ...115

5.7 HeartWare® Monitor Care.....116

5.1 General Overview

To turn the monitor ON, press and hold the power button until the monitor software starts up.

The power button is located on either:

1. The top right side (monitor REF1510) or
2. The left side, top (monitor REF1520 or REF1521)



Figure 65



CAUTION: ALWAYS fully charge the monitor's internal battery prior to patient use.

CAUTION: DO NOT allow patients to touch the monitor, as this may lead to the entering of unwanted HeartWare™ HVAD™ System parameters.

The monitor (**Figure 65**) is designed to use AC power from a wall outlet. The monitor can also use its internal battery during patient transportation. Keep the monitor's battery charged by connecting the monitor AC adapter to an electrical outlet at all times – even while in storage. It takes approximately 4 hours to charge a depleted battery. If the monitor is going to be stored for a long period, removing the battery and leaving the monitor unplugged is also an option.

NOTE: The monitor should always use AC power except during patient transport.



WARNING! DO NOT plug the HeartWare® Battery Charger or monitor AC Adapter into an electrical outlet which is not properly grounded or you may receive a serious electrical shock.

5.1 General Overview (continued)

The monitor is designed to provide a user-friendly way to monitor and control the HeartWare™ HVAD™ System. The monitor:

- Displays pump information
- Allows users to adjust pump parameters
- Monitors and reports system errors and alarm conditions
- Updates controller software, when applicable

Figure 66: Monitor Screen Layout

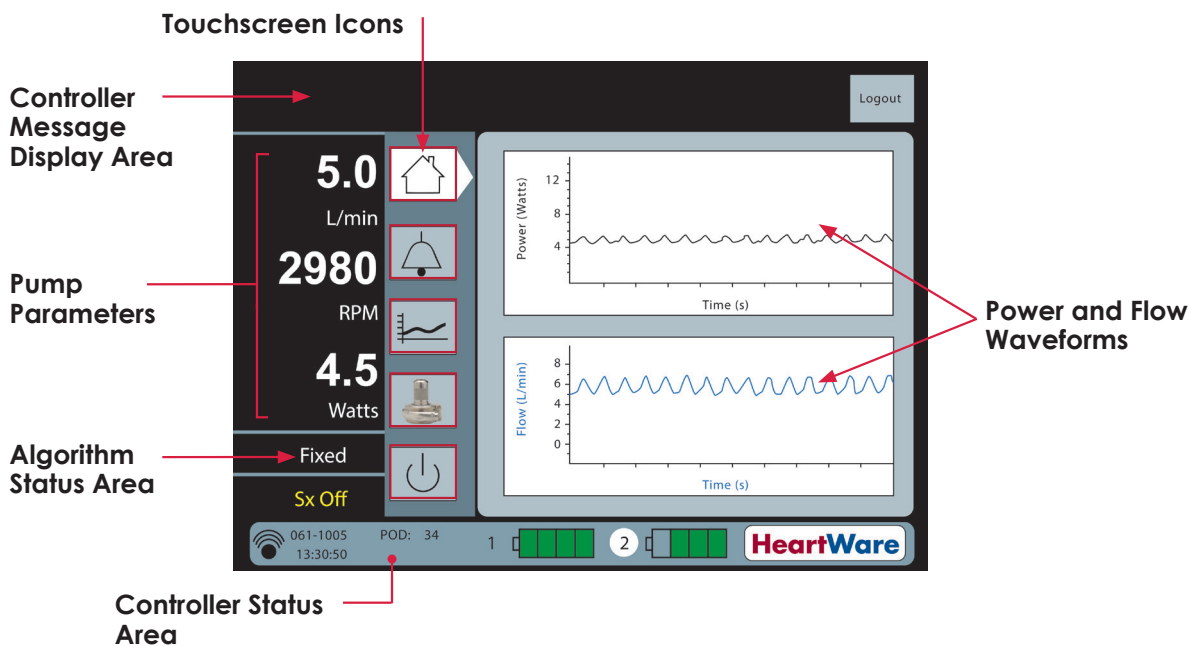

There are five icons (Figure 67) on the monitor to access system information and to manage pump operation. The icons are displayed on all screens. When an icon is selected, it points to the screen.

Figure 67: HeartWare® Monitor Screen Icons



Home:

- Default screen
- Used for routine monitoring
- Displays average flow, speed, power, algorithm status
- Displays real-time power and flow waveforms



System:

- Requires password – 68773
- Enables clinician to:
- Change pump settings
 - Review pump settings
 - Program controllers
 - Turn pump off



Alarm:

- Displays alarm history
- Provides actionable instructions during active alarm
- Provides troubleshooting tips during active alarm



Monitor:

- Turns on/off monitor (will not affect pump operation)



Trend:

- Displays historical trends
- Offers multiple time interval displays (60 min, 4 hours, 14 days, 30 days)

5.2 Informational Screens

Examples of the Clinical (home), Alarm and Trend screens are below:

Figure 68: Clinical Screen

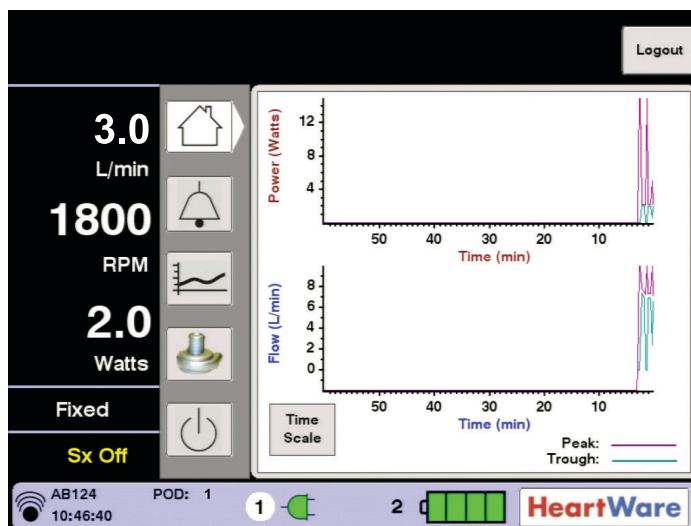

 For additional information on setting speed and flow waveform (pulsatility), see Section 7.1.1.

Figure 69: Alarm Log

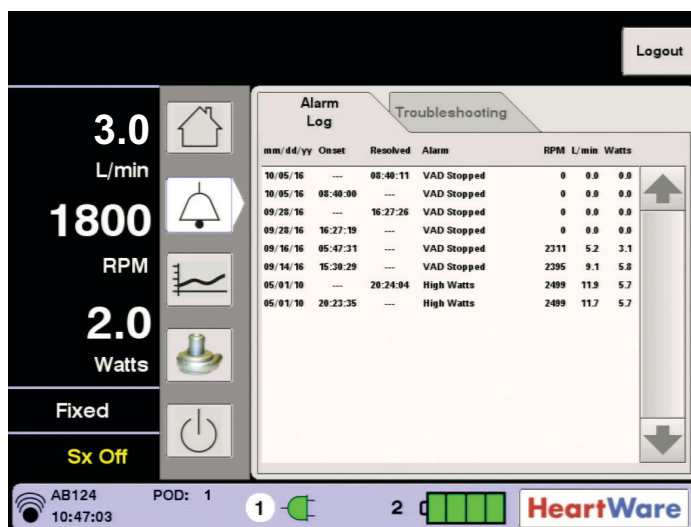

5.2 Informational Screens (continued)

Figure 70: Troubleshooting Tab

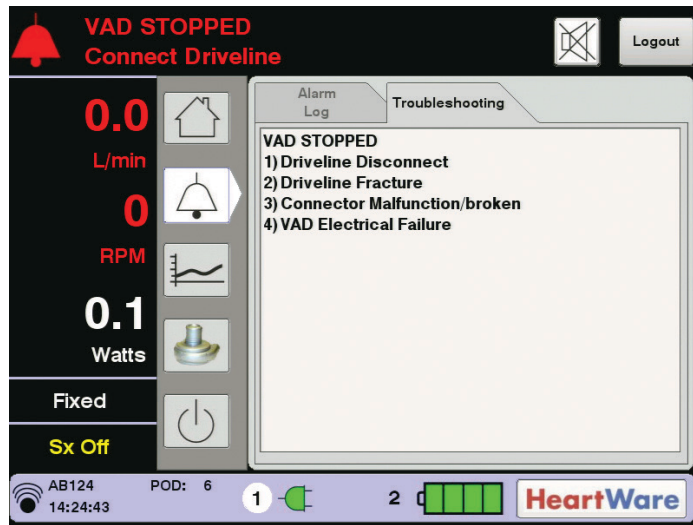

For additional information on alarms, see Section 8.1.

Figure 71: Trend Screen

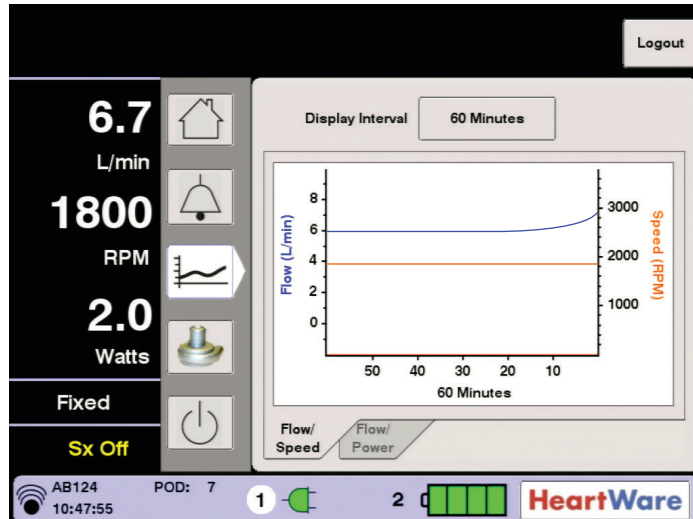

Trend data is uploaded from the controller to the monitor by connecting the monitor data cable to the controller.



For additional information on downloading controller log files, see Section 5.4.

5.3 System Screens

The System Screen is accessed by pressing the HVAD® Pump  icon.

The System Screen is password-protected. HeartWare will provide the clinician with a password. The dialog box (**Figure 72**) is used to enter the numeric password. User access is timed out after 11 minutes of non-use. **(password is 68773)**

Once in the System Screen there are multiple pages, each identified by a tab. The main 3 tabs are found at the bottom of the System Screen page – Speed/Control, SetUp and Alarm Settings. Each page is outlined in detail below:

Figure 72:
Password Dialog Box

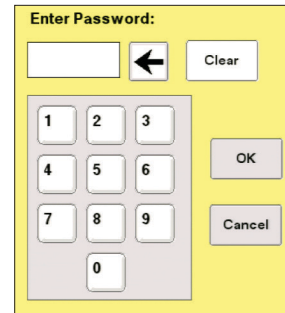

Speed/Control Tab

The System Screen displays waveforms with real-time estimated flow (L/min) or real-time power (Watts). The preferred waveform is selected by pressing the Flow or Power tab (**Figure 73**).

Figure 73: System Screen

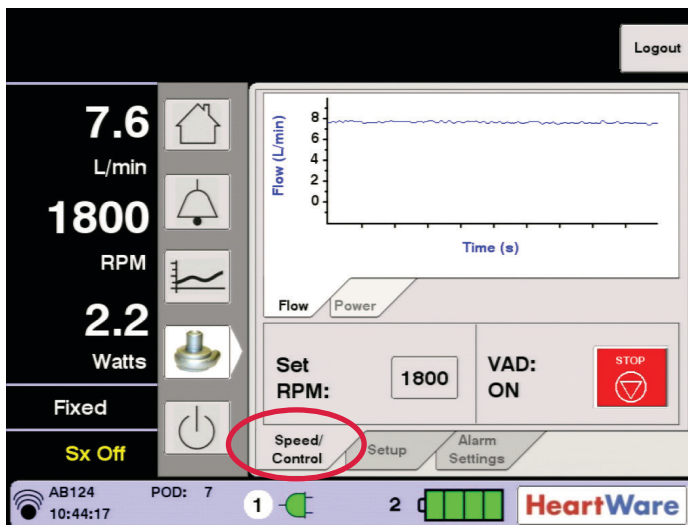

The Speed/Control tab is used to adjust RPM and to turn the VAD on or off. The “Set RPM” button is used to adjust the pump speed (RPM) from 1800 to 4000 and the “VAD” button is used to turn the pump on and off. When the “Set RPM” button is pressed, a dialog box will appear with an up arrow and a down arrow. Pressing the up or down arrow will change the pump speed in increments of 20 RPM.

NOTE: After perioperative period, recommended pump speed during patient support is 2400 RPM to 3200 RPM.

5.3 System Screens (continued)

Speed/Control Tab (continued)

Confirm the speed adjustment by pressing the “Change” button. The HVAD® Pump button is colored and labeled according to the running state of the HVAD® Pump:

- VAD: ON means the HVAD® Pump is pumping; the button is RED and labeled STOP. To stop VAD, press STOP.
- VAD: OFF means the HVAD® Pump is NOT pumping; the button is BLUE and labeled START. To start VAD, press START (**Figure 74**).
- A dialogue box will appear prompting the user to confirm each action.

Figure 74: System Screen – VAD Start

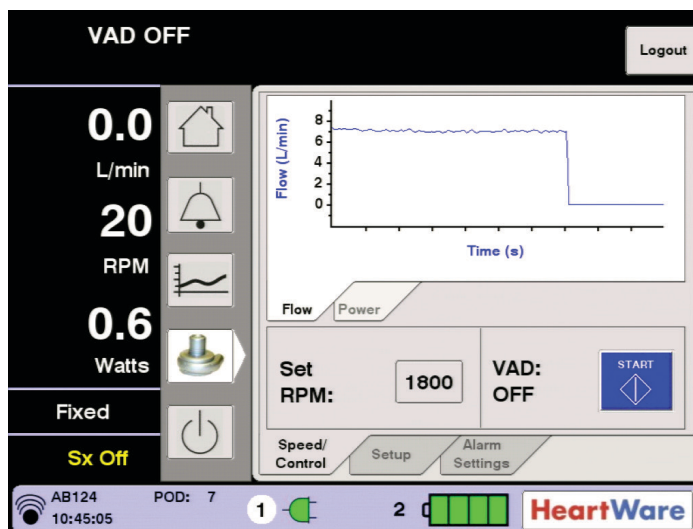

Setup Tab

When the Setup tab is pressed, four additional tabs are displayed and include: Patient, VAD, Controller and Monitor (**Figure 75**). The function of each is described below.

Figure 75: Setup Tab

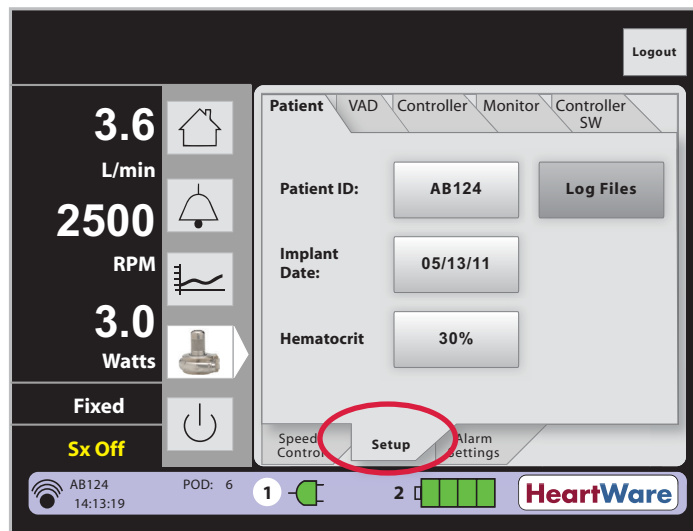

5.3 System Screens (continued)

Patient Tab

The Patient tab is used to enter Patient ID, Implant Date and Hematocrit. Press the Patient ID button to enter patient identification. The patient ID is entered by using the keypad (**Figure 76**). The A to Z and 0 to 9 tabs allow entry of numbers or letters.

Figure 76: Patient ID Dialog Box

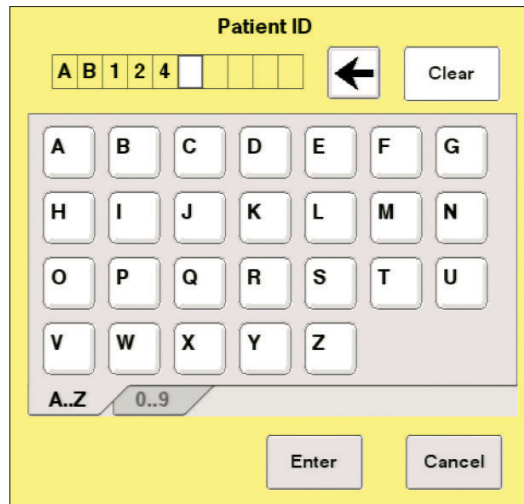

NOTE: Patient ID must be entered for patient's alarms to be displayed in the monitor's alarm log.

Press the "Implant Date" button and enter the HVAD® Pump implant date using the keypad. Use the "Enter" button to confirm entry or the "Cancel" button to cancel entry (**Figure 77**).

Figure 77: Implant Date Screen

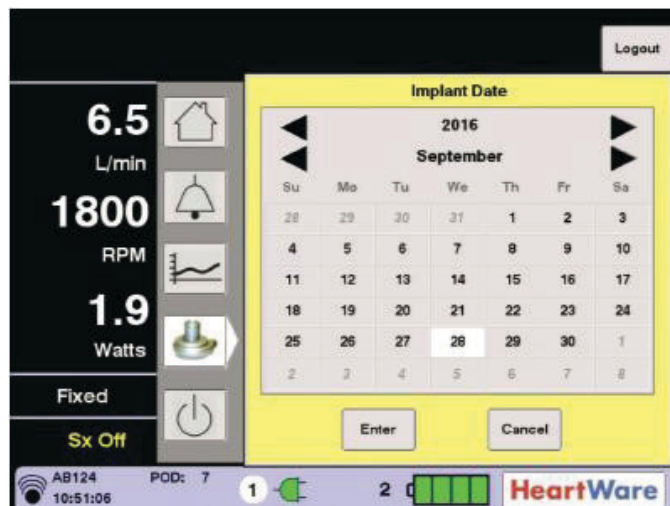

The hematocrit can be changed using the "Hematocrit (%)" button (refer to **Figure 75**). This method allows the clinician to manually input the patient's hematocrit using a measurement obtained from a blood sample. The default hematocrit value is 30%.

5.3 System Screens (continued)

VAD Tab

The VAD tab (**Figure 78**) is used to enable or disable the Suction Response, enable or disable the Lavare™ Cycle and to enter the HVAD® Pump serial number.

NOTE: Monitor REF1510 does not provide access to the “Lavare Cycle” algorithm.

Figure 78: VAD Tab

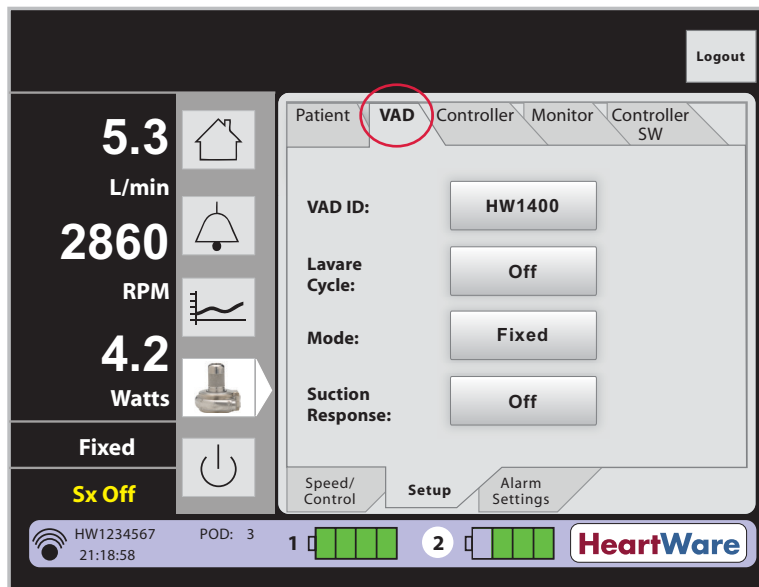

Press the “VAD ID” button to enter the HVAD® Pump serial number from the Implant Kit package. After pressing the “VAD ID” button, a dialog box is displayed (**Figure 79**) and the serial number is entered by using the keypad to enter letters and numbers. The first two letters of the VAD ID are fixed with the letters “HW”. After the information is entered, press the “Enter” button. If an incorrect number is entered, press “Cancel” and start again.

Figure 79: VAD ID Dialog Box

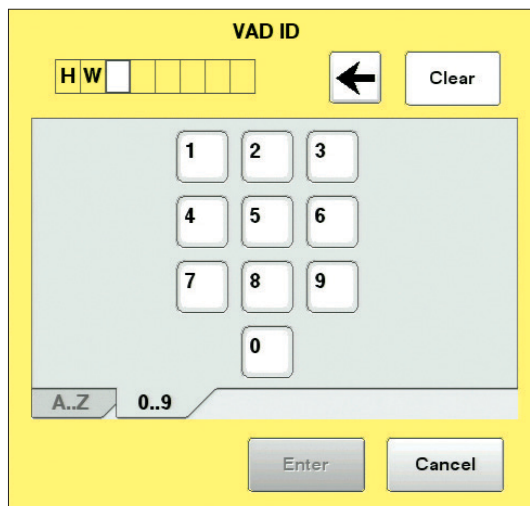

5.3 System Screens (continued)

VAD Tab (continued)

The “Suction Response” button includes two options for suction detection:

- Suction Response “Off”. This is the default setting.
- Suction Response on with “Alarm”. An alarm will sound if a suction event is detected.



For additional information on suction detection, see Section 3.2.2.

When the pump speed is changed by accessing the Speed/Control tab, the dialog box reminds users that this will disable the suction detection alarm (**Figure 80**).

Figure 80: Dialog Box for Pump Speed Changes

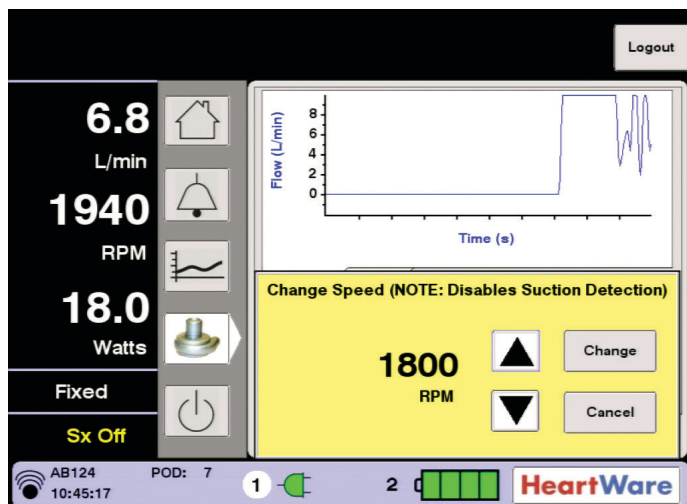
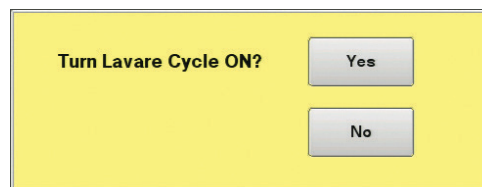

Figure 81: Lavare™ Cycle Button



To turn the Lavare™ Cycle on, press the “Lavare Cycle” button. A dialog box displays, “Turn Lavare Cycle ON?” Press “Yes” (**Figure 81**).

To turn the Lavare™ Cycle off, when using the HeartWare® Monitor REF1510, care must be taken not to do so during the cycle or certain alarms may become disabled:

- 1) From the VAD tab, observe the speed display.
- 2) Note when the Lavare™ Cycle commences (a decrease in speed of approximately 200 RPM).
- 3) Wait 15 to 30 seconds and then press the “Lavare Cycle” button. A dialog box displays, “Turn Lavare Cycle OFF?”
- 4) Press “Yes” to turn the Lavare™ Cycle off.



For additional information on the Lavare™ Cycle see Section 3.2.3.

5.3 System Screens (continued)

Controller Tab

The Controller tab (**Figure 82**) allows the user to enter the controller date, time and language and activate the 'Disable "VAD Stop" Alarm' feature. Monitor REF1510 also allows the user to set the controller default values.

Figure 82: Controller Tab

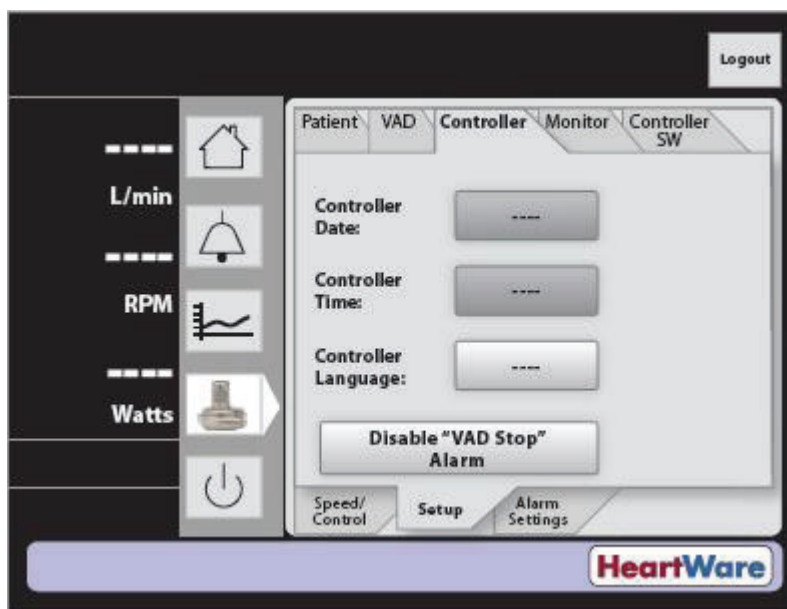

Press the "Controller Date" and "Controller Time" buttons to enter the controller date and time, respectively.

Press the "Controller Language" button to change the language in the controller.

NOTE: Monitor REF1510 does not provide access to controller language options.

Set Defaults (Monitor REF1510 only): The "Set Defaults" (**Figure 83**) button on monitor REF1510 sets the controller parameters to the original manufacturer settings listed below:

- Set Speed is 2500 RPM
- [Low Flow] alarm threshold is 1.0 L/min
- [High Power] alarm threshold is 16.0 Watts
- Suction Response is "Off"
- "Lavare™ Cycle" is "Off"
- Data Log Interval: 15 minutes
- Hematocrit is 30%

NOTE: A controller reset (removal of both power sources) is required following a "Set Defaults" command for the command to take effect.

5.3 System Screens (continued)

Controller Tab (continued)

Figure 83: Default Setting ("Set Defaults" does not appear on monitor REF1520 nor REF1521)

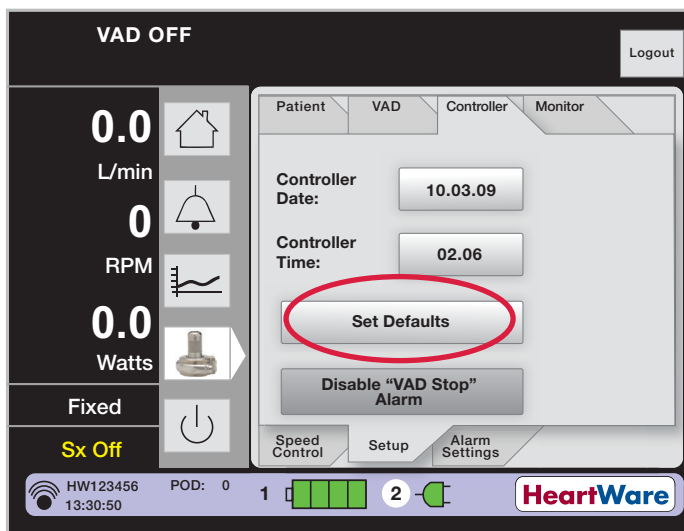

CAUTION: DO NOT use the "Set Defaults" button on monitor REF1510 when a controller is connected to a patient. Pressing it will erase all patient VAD parameter information from the controller.

Disable "VAD Stop" Alarm

The purpose of this feature is to allow programming of a controller when it is not connected to a pump (or a motor fixture). After applying power to the controller, it will pause for ten seconds before detecting whether or not a pump is disconnected (a "VAD Stopped" condition). The Disable "VAD Stop" Alarm feature enables the user to send a command to the controller to tell it NOT to alarm when a pump is not attached. This allows the input of patient and controller information via the monitor without an audible alarm. This pending command will clear after 3 minutes.

Steps:

1. Press 'Disable "VAD Stop" Alarm' indicator on monitor (**Figure 84**).
2. Connect monitor to controller.
3. Power up controller with 2 power sources.
4. Enter patient and controller information via the monitor.
5. Disconnect monitor from controller.
6. Disable [No Power] alarm by pressing the "Alarm Mute" and "Scroll" buttons simultaneously for 5 seconds.
7. Disconnect power from controller.
8. The [VAD Stop] alarm will be re-armed automatically after 3 minutes as long as the monitor is not connected to a controller (**Figure 85**).

5.3 System Screens (continued)

Disable “VAD Stop” Alarm (continued)

Figure 84: Disable “VAD Stop” Alarm



Figure 85: Pending VAD Stop Command

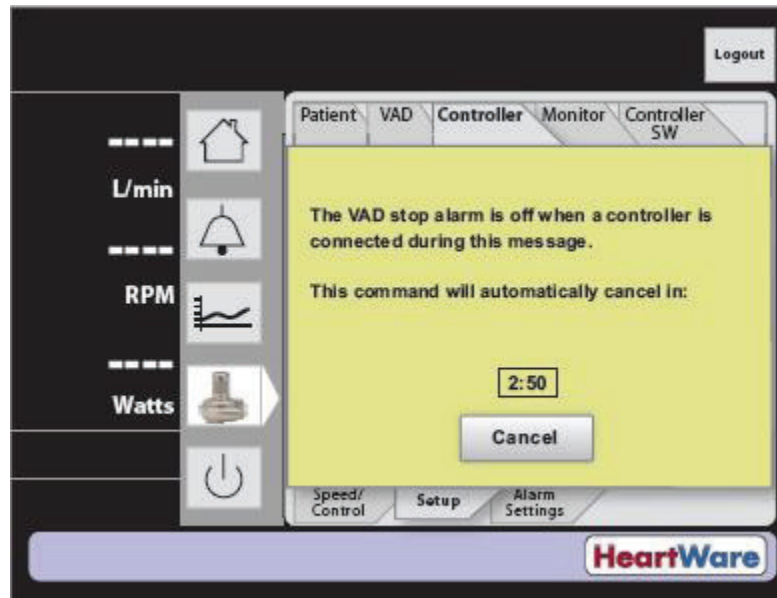

5.3 System Screens (continued)

Monitor Tab

The Monitor tab is used to enter the date and time and to calibrate the monitor touch screen (Figure 86).

- **Monitor Date** and **Monitor Time**: These buttons set the date and time on the monitor.
- **Monitor Language**: Default is English (Figure 87).
- **Touchscreen**: Use this button to initiate touch screen calibration for the monitor. The monitor will only initiate the calibration sequence if the controller is NOT connected to the monitor.

NOTE: Monitor REF1510 does not provide access to monitor language options.

Figure 86: Monitor Tab

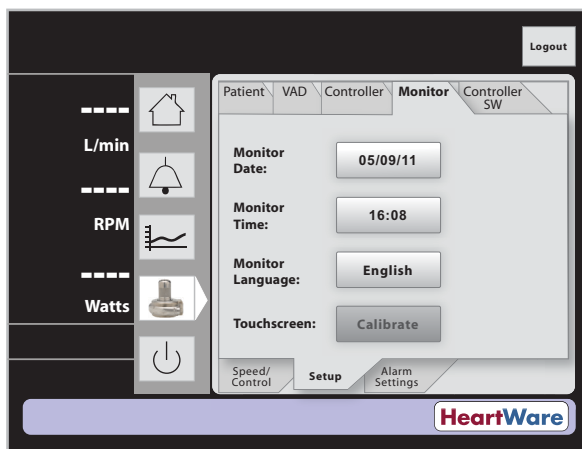
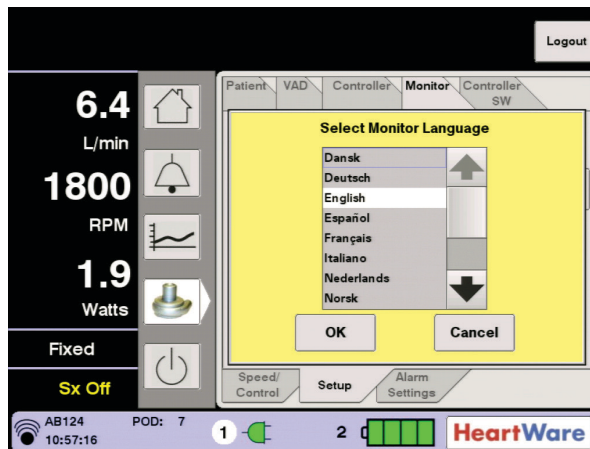

Figure 87: Monitor Language Selection Screen



Alarm Settings Tab

The Alarm Settings tab (Figure 88) is used to set the [Low Flow] Alarm and [High Power] Alarm thresholds. Both flow and power are time averaged values not instantaneous values. The [Low Flow] Alarm threshold may be set from 1.0 L/min to 9.9 L/min in 0.1 L/min increments. The [Low Flow] Alarm should be set at 2.0 L/min below the patient's average flow. Do not set the [Low Flow] Alarm below 2.0 L/min. The [High Power] Alarm may be set from 1.0 Watts to 25.0 Watts in increments of 0.5 Watts. Default settings are 1.0 L/min for [Low Flow] and 16.0 Watts for [High Power]. The [High Power] Alarm should be set 2.0 Watts above the patient's average power. If the flow drops below the low flow threshold (e.g. 1.0 L/min) or the power exceeds the high power threshold (e.g. 16.0 Watts), an alarm is triggered. Clinicians should set the [Low Flow] and [High Power] Alarm thresholds close to the patient's flow and power values, respectively.

NOTE:

- The [Low Flow] alarm should be set at 2.0 L/min below the patient's average flow. DO NOT set the [Low Flow] alarm below 2.0 L/min.
- The [High Power] alarm should be set 2.0 Watts above the patient's average power.

5.3 System Screens (continued)

Alarm Settings Tab (continued)

Figure 88: Alarm Settings Tab

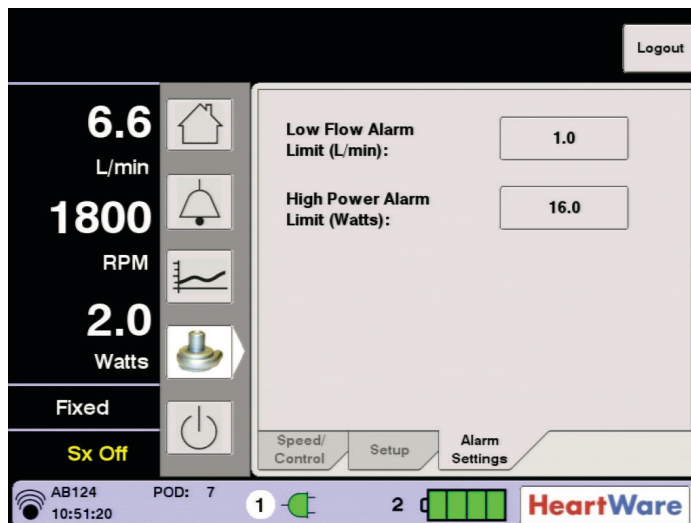

When certain alarm or fault conditions exist, the Alarm Settings tab may be used to access additional controls to silence the audio component of the alarm or fault for extended time periods. The “Controller Fault Audio” button appears during a medium priority [Controller Fault] alarm (**Figure 89**). The “Controller Fault Audio” button can be used to permanently silence a [Controller Fault] alarm. However, the controller and monitor will continue to display the [Controller Fault] alarm until the condition resolves.

Figure 89: [Controller Fault] Audio

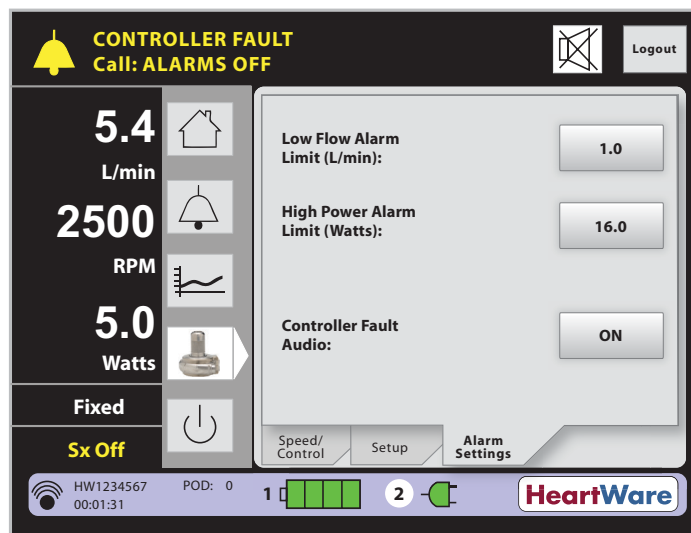

Permanently silencing the [Controller Fault] audible alarm is a two-step process. Pressing the “Silence” button on the monitor touch screen will bring up a confirmation box (**Figure 90**). Pressing the “Yes” button will silence all current medium priority [Controller Fault] alarms. Subsequent controller faults will produce new audible alarms.

5.3 System Screens (continued)

Alarm Settings Tab (continued)

Figure 90: Permanently Silence [Controller Fault] Dialogue Box

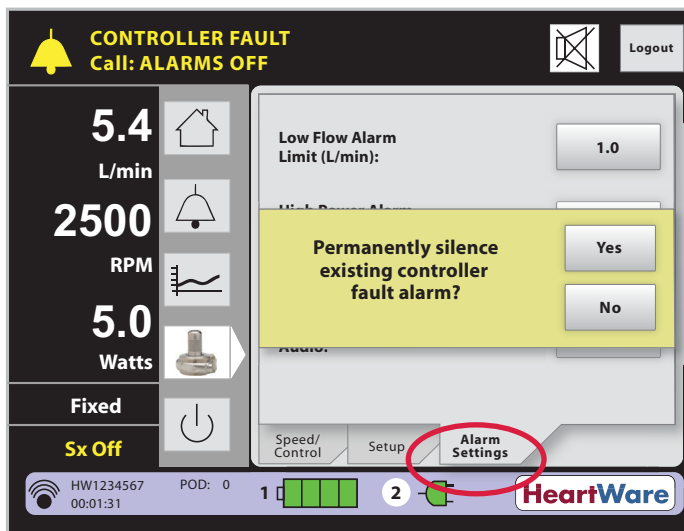

The “Electrical Fault Audio” button appears during a medium priority [Electrical Fault] alarm (Figure 91). The “Electrical Fault Audio” button can be used to permanently silence an [Electrical Fault] alarm. However, the controller and monitor will continue to display the [Electrical Fault] alarm until the condition resolves.

Figure 91: “Electrical Fault Audio” Button

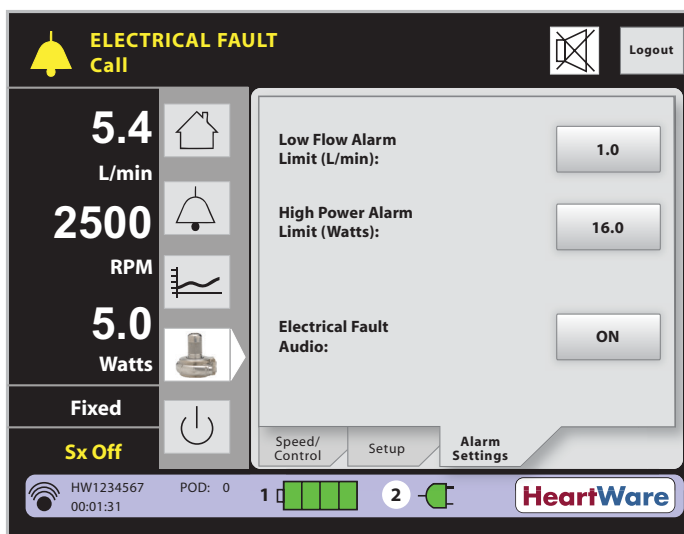

For additional information on alarms, see Section 8.1



WARNING! ALWAYS investigate, and if possible, correct the cause of any alarm. Silencing an alarm does not resolve the alarm condition.

5.3 System Screens (continued)

Alarm Settings Tab (continued)

The user should always log off the password-protected System Screens after completing system adjustments. Press the “Logout” button and confirm by pressing the “Yes” button to return to the Clinical Screen. If the System Screen is not used for 11 minutes, the user is automatically logged out and needs to enter the password to access these screens.

5.4 Downloading Controller Log Files

All logs are maintained in the controller in non-volatile flash memory. The “Log Files” button allows the clinician to obtain alarm and trend data from the controller and to transfer it from the patient’s controller to a USB flash drive.

How to download log files from the controller to the monitor:

1. Connect the blue data cable from the monitor to the data port on the controller (**Figure 92**).



Figure 92

2. The gray data download icon in the lower left hand corner of the monitor screen will flash (**Figure 93**), indicating the download has begun (it may take up to 10 minutes for the download to complete).

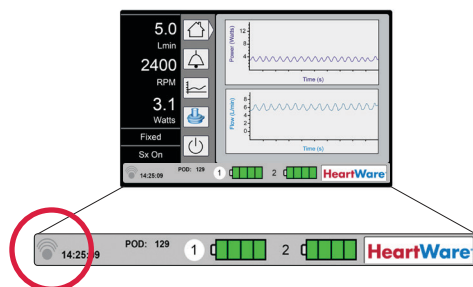

Figure 93

3. When the data download icon turns solid black (**Figure 94**), the data download is complete. Disconnect the data cable from the controller.



Figure 94

Please note: the controller will automatically download log files to the monitor when connected to the monitor.

NOTE: DO NOT disconnect the controller from the monitor when the data transfer icon is flashing, as data is being transferred. If the message, “Log Transfer Not Complete!” appears, re-connect the controller to the monitor to complete the data transfer.

5.4 Downloading Controller Log Files (continued)

How to download log files from the monitor to a USB flash drive:

1. To get started press **HeartWare™ HVAD™ System icon**  on the monitor and enter password: **68773**.

Press Setup tab.

Press Patient tab.

Press "Log Files" button (the "Log Files" button will only appear if the data cable is disconnected).

Figure 95

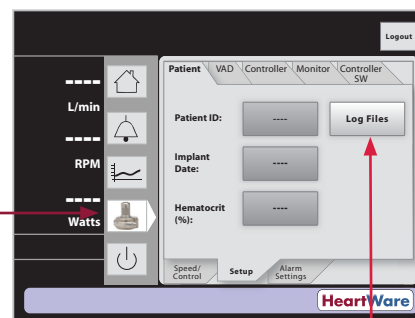

2. Place a HeartWare® Monitor compatible USB memory stick into the USB port on the monitor.
3. Choose patient files to download and follow prompts to save files.

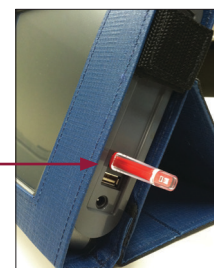

Figure 96

- A confirmation screen will appear to affirm selection. If correct, press "Yes" button.
- A download complete message will appear when data download is complete. Press "OK".

NOTE: The maximum storage for each controller is 3000 entries, which equates to approximately 31 patient days. A USB flash drive can be used intermittently to download data.

5.5 Updating Software on the HVAD® Controller

Software in the HVAD® Controller may be updated using the HeartWare® Monitor when new versions of the software are available. When a new version of controller software is available for installation a notification from HeartWare will be sent describing the update. If needed, a HeartWare representative will update the monitor software and confirm the monitor is able to perform the controller software update. The monitor will display a message that a software update is available when a back-up controller not already updated is connected. Controller software updates include software for the controller's UIC (User Interface Controller) and PMC (Pump Motor Controller). Controller software updates can only be performed on controllers that are not connected to a running pump, such as the patient's back-up controller.

5.5 Updating Software on the HVAD® Controller (continued)

To Identify if a Controller is Ready for an Upgrade:

1. Turn on the HeartWare® Monitor and connect the data cable from the monitor to the data port on the back-up controller.
2. Press the **HeartWare™ HVAD™ System Icon**  on the monitor and enter password: **68773**
3. Disable “VAD Stop” alarm to prevent alarming (**Figure 97**)
 - a. Press Setup tab
 - b. Press Controller tab
 - c. Press ‘Disable “VAD Stop” Alarm’ button

Figure 97: ‘Disable “VAD Stop” Alarm’



4. Connect controller to two power sources.

NOTE: If connected to only one power source, there will be a [Power Disconnect] alarm during the procedure.

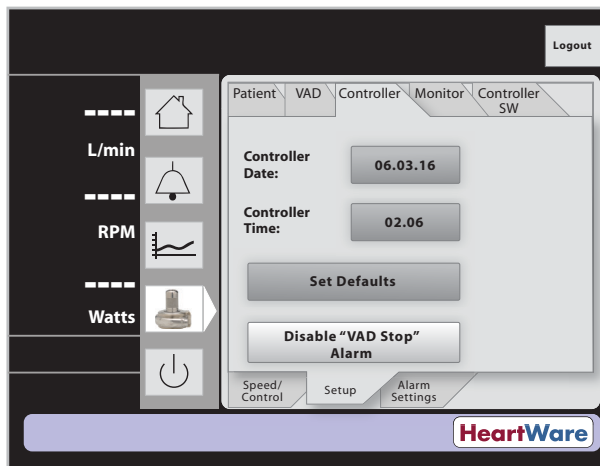
5. The monitor will display a “New Software” message, (**Figure 98**) if a controller software update is available. To proceed with update, press “OK”.
6. Confirm that the current date and time are set correctly and if not, correct the settings.

5.5 Updating Software on the HVAD® Controller (continued)

Figure 98: Controller Software Update Available

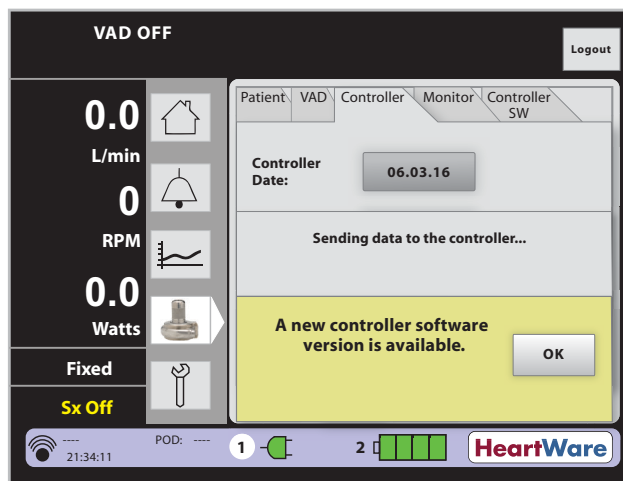

NOTE: Before beginning software update, save patient log files and write down controller settings.

To Perform the Software Update:

7. Press the Controller SW tab (**Figure 99**).

- Both the current controller software version and the replacement (updated) software version are displayed.

Figure 99: Controller SW tab

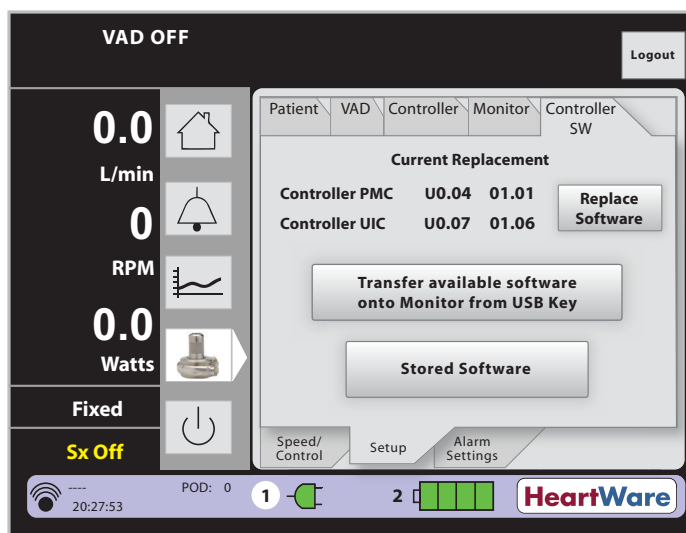

NOTE: The transfer of software onto the monitor from a USB Key will be performed by HeartWare personnel.

5.5 Updating Software on the HVAD® Controller (continued)

8. Begin update:
 - a. Confirm that the replacement software version displayed is the desired controller software version. The desired software version should be the one listed on the latest controller software update notification received from HeartWare.
 - b. Press “Replace Software”.
 - c. Press “Yes” to confirm.

Figure 100: Confirm Controller upgrade

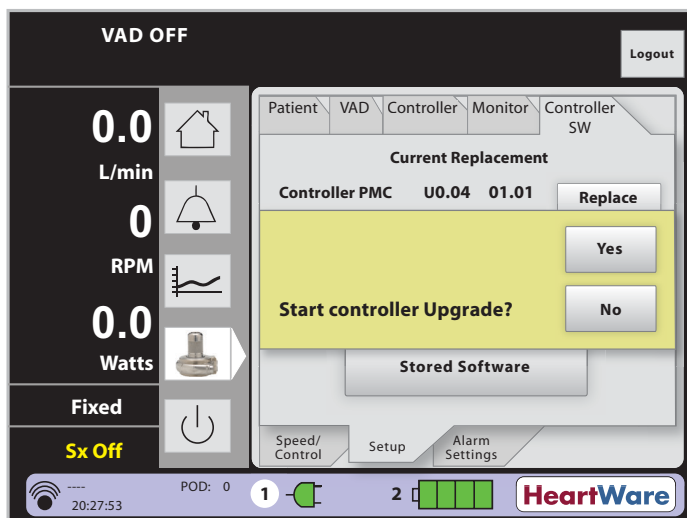

9. The monitor will update the controller software.
10. An “Update Success” message will appear when the software update is complete and it will instruct to ‘Power Cycle’ the controller (**Figure 101**). To Power Cycle the controller please proceed to the next step. (A power cycle is the removal of all power followed by the re-connection of power.)

Figure 101: Successful Update Message

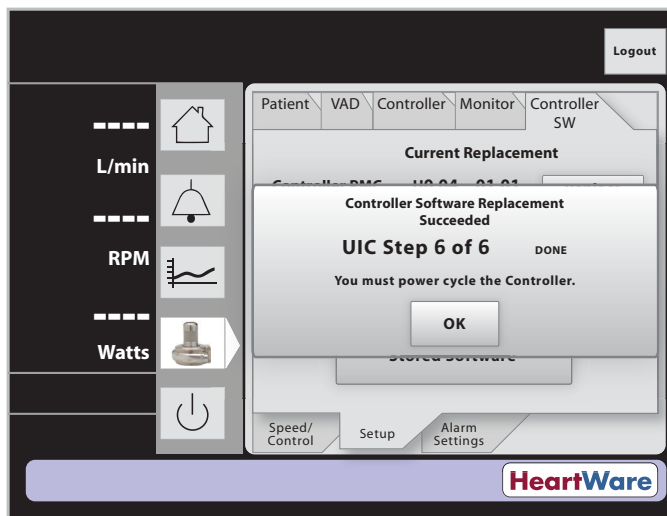

5.5 Updating Software on the HVAD® Controller (continued)

To Perform a Power Cycle on the Controller:

11. To Power Cycle the controller and complete the update process:
 - a. Press "OK".
 - b. Press 'Disable "VAD Stop" Alarm' button (on the Controller tab).
 - c. Disconnect all power sources from the controller.

NOTE: During this process, the [No Power] alarm cannot be silenced and may alarm.

- d. Reconnect power sources to the controller.
12. After powering up the controller:
 - a. Return to the Controller SW tab on the monitor and confirm the UIC and PMC software versions displayed are now the desired versions.
 - b. Watch for high or medium priority alarms. If there is an alarm, repeat update procedure beginning at step 7 (even if the alarm continues to sound). If after repeating the update procedure a high or medium priority alarm returns, remove the controller from use and contact your HeartWare representative. If the controller belongs to a patient, provide a replacement controller.
13. Confirm all controller settings are set accurately, if applicable. Including:
 - a. Set Speed
 - b. Alarm Limits and algorithm settings
 - c. Hematocrit
 - d. VAD and Patient ID

The procedure is complete. It is now safe to disconnect the controller from the monitor and shutdown the controller.

5.6 Monitor Shutdown

Monitor Shutdown

The Monitor On/Off  Icon is used to shut down the monitor program.

NOTE: Always press the On/Off icon on the screen before pressing the power button or data may be lost.

5.6 Monitor Shutdown (continued)

A dialog box will appear after pressing the Monitor On/Off Icon asking you to confirm (**Figure 102**):

Figure 102: Confirming Monitor Shutdown

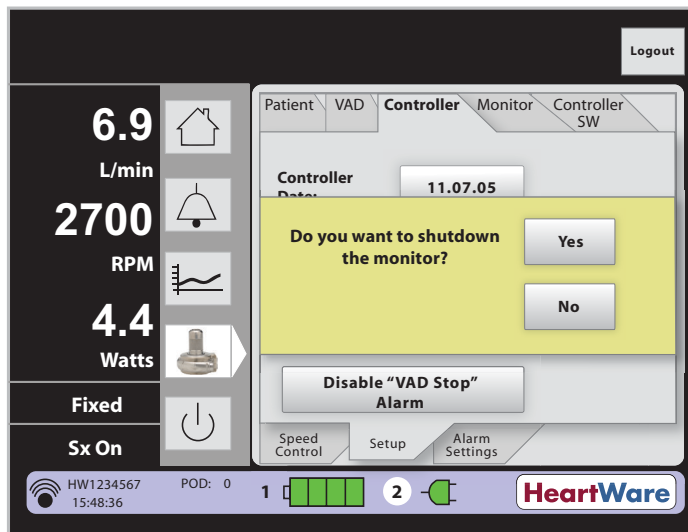

Press "Yes" to exit the program. When the "It is now safe to turn off power" prompt appears on the monitor press the monitor power button.

To completely power off, you must press AND HOLD the power button until the screen shuts off OR

Press "No" to return to the program.

5.7 HeartWare® Monitor Care

Once a month: If not in use, check to be sure the monitor is plugged into an AC outlet. This will keep the internal monitor battery charged. If the monitor battery fails to hold a charge, or lasts less than one hour, please contact HeartWare for a replacement. Also, check the monitor AC adapter and power cord for wear or damage and confirm they are working correctly. Turn off the monitor prior to cleaning. Clean the monitor screen with a soft, lint-free cloth. A damp cloth may be used but a wet cloth should not. Use care to avoid scratching or damaging the screen.



WARNING! NEVER clean the monitor with the power on, as this may lead to an electrical shock. DO NOT use alcohol or detergent on the monitor display. Gently wipe the display with a soft, lint free cloth.

5.7 HeartWare® Monitor Care (continued)

Periodically or as needed:

The HeartWare® Monitor may be cleaned with:

- Alcohol (Isopropyl 90% or Ethyl 70%)
- Silver, ethanol, acetic acid, peroxyacetic acid, hydrogen peroxide solution (active ingredients of some sporicidal disinfecting wipes)
- UV-C disinfecting wand, one that radiates “short wave” UV-C band rays (100 to 280 nanometers) from a 4 watt bulb (or stronger).

The Monitor AC Adapter may be cleaned with the following agents:

- Alcohol (Isopropyl 90% or Ethyl 70%)
- Hydrogen peroxide solution (1.4%)
- n-Alkyl Dimethyl Dibenzyl Ammonium Chloride combined with n-Alkyl Dimethyl Ethylbenzyl Ammonium Chloride (active agent in some disinfecting wipes)
- Silver, ethanol, acetic acid, peroxyacetic acid, hydrogen peroxide solution (active ingredients of some sporicidal disinfecting wipes)
- UV-C disinfecting wand, one that radiates “short wave” UV-C band rays (100 to 280 nanometers) from a 4 watt bulb (or stronger).

The Data Cable may be cleaned with the following agents:

- Alcohol (Isopropyl 90% or Ethyl 70%),
- Hydrogen peroxide solution (1.4%),
- n-Alkyl Dimethyl Dibenzyl Ammonium Chloride combined with n-Alkyl Dimethyl Ethylbenzyl Ammonium Chloride (active agent in some disinfecting wipes), or bleach solution (10%).
- Silver, ethanol, acetic acid, peroxyacetic acid, hydrogen peroxide solution (active ingredients of some sporicidal disinfecting wipes)
- UV-C disinfecting wand, one that radiates “short wave” UV-C band rays (100 to 280 nanometers) from a 4 watt bulb (or stronger).

Product Disposal

HeartWare® Monitor

The HeartWare® Monitor contains a lithium battery (replaceable). Dispose of/recycle the monitor's internal battery in compliance with all applicable local, state, and federal laws and regulations. DO NOT incinerate discarded monitor batteries.

1

Introduction

2

Overview

3

HVAD® Pump

4

Peripherals
and
Accessories

5

Monitor

6

Surgical
Implant and
Explant

7

Patient
Management

8

Alarms and
Emergencies

9

Reference
Guides

10

Appendix

Notes

+ 6.0 Surgical Implant and Explant of the HVAD® Pump

6.1 Preparing for Implantation119

6.2 Programming HVAD® Controllers121

6.3 HVAD® Pump Pre-Implant Test and Pump Assembly123

6.4 Surgical Implant Procedure127

6.5 HVAD® Pump Explant133

6.1 Preparing for Implantation

Equipment for Implant

Figure 100 shows the HeartWare™ HVAD™ System components used at implant (provided ETO sterilized).

- **HVAD® Pump**
- **Outflow graft** – a 10mm diameter gel impregnated graft
- **Strain relief** – to prevent outflow graft kinking
- **Sewing ring** – to secure the HVAD® Pump to the left ventricle
- **Driveline cap** – to protect the driveline connector when tunneling
- **Inflow cap** – to cover the pump inflow cannula after the wet test and prior to implantation
- **Driveline extension cable** – used only during the pre-implant wet test to keep the non-sterile controller isolated from the sterile field. The driveline extension cable is not intended to be used after the pump is implanted in the patient



WARNING! The HVAD® Pump may cause interference with AICDs. If electromagnetic interference occurs it may lead to inappropriate shocks arrhythmia and possibly death. The occurrence of electromagnetic interference with AICD sensing may require adjustment of lead sensitivity proximal placement of new leads or replacement of an existing sensing lead.

6.1 Preparing for Implantation (continued)

Equipment for Implant (continued)

Figure 103: Components used at Implant

- 1 HVAD® Pump
- 2 Outflow graft
- 3 Sewing ring (made of titanium and polyester)
- 4 Driveline cap
- 5 Strain relief
- 6 Inflow cap
- 7 Driveline extension cable



A set of surgical tools (provided ETO sterilized) is also required for implantation of the device (Figure 104).

Figure 104: Surgical Tools

- 1 **Tunneler** – to tunnel the pump's percutaneous driveline through the skin to the exit site
- 2 **Sewing ring wrench** – to tighten the screw on the sewing ring
- 3 **Driveline cover** – to cover the driveline connection to the controller
- 4 **Apical coring tool** – to core the LV apex
- 5 **Hex driver** – to secure the strain relief and outflow graft to the HVAD® Pump

All tools and accessories used during implantation are for single-use only.

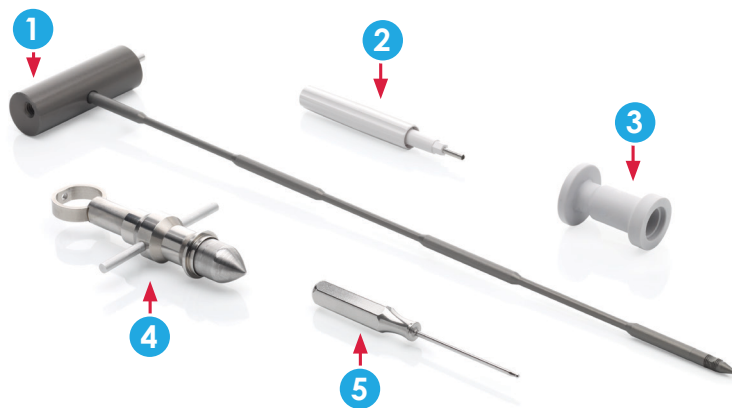

CAUTION: DO NOT use HeartWare equipment in the presence of a flammable anesthetic mixture with air or with oxygen or nitrous oxide. (NOTE: Flammable anesthetics are typically ether based).

6.1 Preparing for Implantation (continued)

Battery Charger

1. Connect the battery charger power cable to an electrical outlet. Verify the power indicator is lit next to "HeartWare".
2. Verify availability of four fully charged batteries. If batteries are not fully charged, start charging depleted batteries at least 5 hours before the HVAD® Pump implant procedure.

Monitor

1. Turn the monitor on. Connect the monitor data cable to the data port on the controller.
2. Press the HVAD® Pump Icon to access the System Screen and enter the password.
3. Press Setup tab to display Patient, VAD, Controller, and Monitor tabs.
4. Press the Monitor tab and enter monitor date and time.



For additional information about the monitor, see Section 5.0.

6.2 Programming HVAD® Controllers

Follow the steps below to program the back-up controller. This should be done before the primary controller.

1. Press the Controller tab on the Setup Screen, and then press the 'Disable "VAD Stop" Alarm' button.
2. If not already done, connect the monitor data cable to the data port on the controller. Connect power to the controller, either AC adapter or battery. Note: if only 1 power source is connected, after 20 seconds a connect battery alarm will begin.

NOTE: Once powered, the controller performs a self-test and will display a temporary message regarding the status of the self-test. If the controller fails the self-test, a [Controller Fault] alarm message will appear. In that case replace the controller with the second controller.

3. Press Speed/Control tab and reduce the set speed to 1800 RPM.
4. Press Setup tab to display Patient, VAD, Controller, and Monitor tabs.
5. Press the Patient tab and enter the Patient ID and Implant Date.
6. Ensure the Hematocrit setting is 30%.
7. Press VAD tab and enter HVAD® Pump serial number and verify that Suction Response and the "Lavare Cycle" is "Off".
8. Press Controller tab and enter controller date and time.
9. Press the Alarm Settings tab to set the [Low Flow] alarm limit and [High Power] alarm limits. Default settings are 1.0 L/min for low flow and 16.0 Watts for high power.

6.2 Programming HVAD® Controllers (continued)

10. Remove data cable.
11. To prevent the controller alarm from sounding after the power is removed, follow these instructions:
 - If a red alarm adapter is available: Insert it into the connector on the controller.
 - If no alarm adapter is available: Press and hold the “Alarm Mute” and “Scroll” buttons on the controller until a “beep” is heard, or for at least 5 seconds.
12. Disconnect both power sources from controller.
13. Set the back-up controller aside for use during the Pre-Implant Test.



For additional information about the monitor, see Section 5.0.



CAUTION: A back-up controller should always be available and programmed identically to the primary controller.

To program the primary controller, first follow the steps performed above to program the back up controller. It is important however, to read the steps below to ensure power remains connected to the primary controller. This will allow for manual pump start when ready.

1. Press the Controller tab on the Monitor Setup Screen, and then press the ‘Disable “VAD Stop” Alarm’ button.
2. Connect the monitor data cable to the data port on the controller.
3. Connect power to the controller. Recommend connecting both power sources.
4. Press Speed/Control tab and reduce the set speed to 1800 RPM.
5. Press Setup tab to display Patient, VAD, Controller, and Monitor tabs (see “Setup Tab” in Section 5.3).
6. Press the Patient tab and enter the Patient ID and Implant Date.
7. Ensure the Hematocrit setting is 30%.
8. Press VAD tab and enter HVAD® Pump serial number and verify that Suction Response is “Off” and the “Lavare Cycle” is not enabled.
9. Press Controller tab and enter controller date and time.
10. Press the Alarm Settings tab to set the [Low Flow] alarm limit and [High Power] alarm limits. Default settings are 1.0 L/min for low flow and 16.0 Watts for high power.
11. Press the “Logout” button and return to the Clinical (Home) Screen
12. After setting up the primary controller, keep power connected to the controller so that the pump does not stop, then restart automatically when power is restored. During implant the HVAD® Pump should be started only by pushing the password-protected “Start” button.



For additional information on the “VAD Stop” button , see Section 5.3.

6.2 Programming HVAD® Controllers (continued)

- Place the controller in the carrying case and position the case close to the head of the OR table so the driveline can be connected to the controller after tunneling.



WARNING! Keep power connected to the controller after setting up the primary controller to minimize the risk of air embolus during implant. Disconnecting and then reconnecting power will result in the controller starting the pump as soon as the driveline is connected.

NOTE: Any changes to the primary controller should also be made to the back-up controller.

6.3 HVAD® Pump Pre-Implant Test and Pump Assembly

- Examine the HVAD® Pump implant kit package and other component packaging. They must be unopened and without any visible damage including abrasion, delamination or punctures.



WARNING! DO NOT use if package is damaged or opened. Sterile components are intended for single use only. DO NOT re-sterilize or re-use as this will increase the risk of infection.

- Set up a sterile back table to prepare and test the HVAD® Pump.
- Open the driveline extension cable first. Pass it onto the sterile field, wipe it off with a damp sponge and set on sterile back table. Dispose of sponge and change gloves.

NOTE: The driveline extension cable should only be used during the pre-implant test. It should not be used after the VAD is implanted.

- Grasp the Tyvek® lid of the HVAD® Pump implant kit package at the point indicated and peel back, taking care not to contaminate the inner sterile tray.
- Pass the HVAD® Pump tray and other components aseptically onto the sterile field. Examine all components, including the surgical tools, for damage, corrosion or any abnormalities that might affect the safety or functionality of the tools. If any abnormalities are noted please use the appropriate back-up supplies.
- Cover the HVAD® Pump with a sterile towel. With the driveline extended on the back table, remove the Tyvek® sleeve (peel off by hand) covering the polyester covered portion of the driveline (**Figure 105**). Wipe the driveline with a lap sponge moistened with antibiotic irrigation and discard the sponge.

Figure 105: Tyvek® sleeve covering polyester on driveline

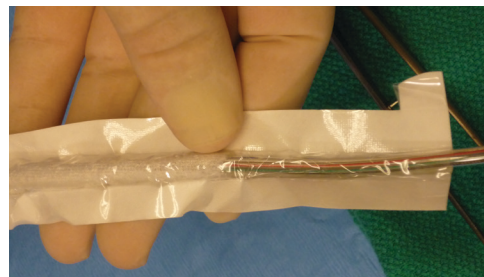

6.3 HVAD® Pump Pre-Implant Test and Pump Assembly (continued)

7. On the sterile field, fill a basin with enough 5% dextro solution to establish at least 4.0 inches (10.2 centime of fluid above the pump inflow (**Figure 106**).
8. Attach the sterile driveline extension cable to the HVAD® Pump and pass the distal portion of the cabl (labeled “Controller”) to the non-sterile assistant.

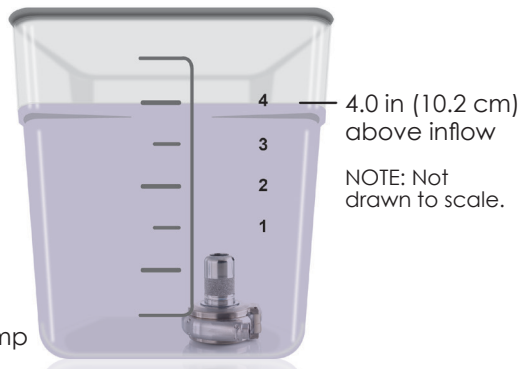

Figure 106: Submerged pump



WARNING! ALWAYS check for an audible click when connecting the driveline to the controller or driveline extension cable. Failure to ensure a secure connection may cause electrical fault.

9. Clamp the sterile portion of the extension cable to the sterile field on the table to prevent cable movement.
10. The non-sterile assistant should have the back-up controller and a charged battery ready for use. Completely submerge the HVAD® Pump in the dextrose solution. Fill the pump with dextrose and gently rotate it in the dextrose to allow any trapped air to escape.
11. At least 4 inches (10.2 cm) of dextrose solution must be above the VAD inflow and outflow conduits. Failure to have enough fluid above the inflow cannula may result in air ingestion, damage to the pump and [Low Flow] alarms.
12. When the HVAD® Pump is completely submerged in the sterile basin and is de-aired, point the inflow cannula towards the wall of the basin and position a hand above the VAD outflow to prevent dextrose from squirting out of the basin.
13. The non-sterile assistant should connect the driveline extension cable to the controller, ensuring that there is an audible click when making the connection. Push the driveline extension cable boot forward to cover the exposed metal driveline connector and the mating connecting on the controller.
14. Connect the battery to the controller.
15. The pump will start at 1800 RPM.



WARNING! NEVER turn on the HVAD® Pump in air as this may damage the pump. DO NOT use an HVAD® Pump that was turned on without total submersion in fluid during the pre-implant test and prior to implantation: The HVAD® Pump must be completely submerged in fluid before being turned on.

NOTE: During the HVAD® Pump Pre Implant Test, a low priority alarm will sound since one of the controller power ports is empty.

6.3 HVAD® Pump Pre-Implant Test and Pump Assembly (continued)

16. Run the HVAD® Pump for 30 – 60 seconds. As part of the normal HVAD® Pump startup algorithm, the monitor and controller may momentarily display power values greater than 3.0 Watts before settling at a lower power. Allow for both power and speed to stabilize (this may take 5-10 seconds). If, after the pump has started and both the power and speed have stabilized, the power exceeds 3.0 Watts; DO NOT use the pump. Set it aside and repeat this test using the back-up HVAD® Pump.
17. After the test is complete, disable the [No Power] alarm. If a red alarm adapter is available, insert it into the connector on the back-up controller. If no alarm adapter is available, press and hold the “Alarm Mute” and “Scroll” buttons until a “beep” is heard, or for at least 5 seconds. Remove the battery from the controller. This will power down the controller and will stop the pump.
18. Wearing clean, dry gloves, disconnect the driveline extension cable from the controller and the HVAD® Pump.
19. Connect the driveline cap to the driveline by pushing both connectors together until you feel a “click” (Figure 107). Protect the connector from exposure to fluids.
20. Cover the inflow cannula of the HVAD® Pump with the yellow inflow cap.

Figure 107: Driveline cap connection



Outflow Graft Attachment

1. Examine the outflow graft package. It must be unopened and without visible damage.



WARNING! DO NOT implant gel impregnated vascular prostheses in patients who exhibit sensitivity to polyester or materials of bovine origin, as severe reactions may occur.

2. Open the package aseptically, taking care not to contaminate the sterile graft.



WARNING! DO NOT allow the Gelweave™ prostheses non-sterile foil pouch or outer tray to be introduced to the sterile field or the sterile field will be contaminated. Only the innermost tray is sterile.

WARNING! DO NOT preclot the outflow graft. Preclotting may disrupt the gel matrix, resulting in bleeding. Gelweave™ prostheses are sealed grafts and must not be preclotted.

WARNING! DO NOT implant the Gelweave™ prostheses more than one month after removal from the foil pouch. This may disrupt the gel matrix, resulting in bleeding.

3. Pass the outflow graft onto the sterile field.

6.3 HVAD® Pump Pre-Implant Test and Pump Assembly (continued)

Outflow Graft Attachment (continued)



WARNING! DO NOT allow anyone but a surgeon, physician's assistant or surgical assistant trained in the procedure to attach the outflow graft to the pump, as a loose graft connection may lead to bleeding and/or an air embolus.

- Slide the strain relief over the outflow graft (**Figure 108**). Next, stretch the outflow graft over the HVAD® Pump outflow conduit (**Figure 109**). Hemostats can be used to assist with the procedure. Verify that the outflow graft is not kinked or twisted. If necessary, reattach graft if kinking or twisting occurs.



CAUTION: DO NOT exert excessive tension or force on the Gelweave™ prostheses as it will damage the polyester fibers and the gelatin impregnation, which may result in bleeding.



Figure 108: Strain relief over outflow graft



Figure 109: Stretch outflow graft over pump outflow conduit

- Loosen the graft clamp screw and place the graft clamp over the lip of the HVAD® Pump outflow conduit. Verify that the clamp screw is on the outflow conduit and attached to the graft clamp. If the clamp screw is completely removed or if it falls out, be sure to re-insert it correctly as the clamp has threads on only one side.
- Position the clamp screw so that it is located on the inner side of the outflow conduit (**Figure 110**). Tighten the clamp screw until resistance is met.

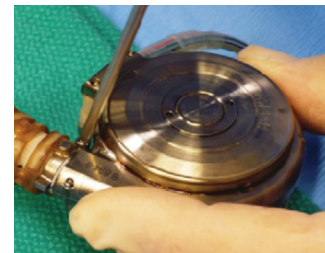

Figure 110: Position the clamp screw to inner side of outflow conduit



WARNING! ALWAYS position the clamp screw so that it is located on the inner side of the outflow conduit to avoid tissue irritation or damage.

WARNING! DO NOT use excessive force when tightening the clamp screw because this could damage the graft clamp or graft clamp screw and a loose connection may result in bleeding and/or an air embolus. Replace components if required.

6.3 HVAD® Pump Pre-Implant Test and Pump Assembly (continued)

Outflow Graft Attachment (continued)

7. Gently pull on the outflow graft to verify secure placement of the graft clamp to the outflow conduit.
8. Inspect the outflow graft and strain relief for any kinks or twisting. Reattach the outflow graft if necessary.
9. Clamp the HVAD® Pump outflow graft with a vascular clamp, then wrap it all in a clean towel.

6.4 Surgical Implant Procedure

NOTE: In order to optimize patient outcomes HeartWare suggests that the following techniques be considered at the time of HVAD® Pump implant:

- **TEE**

- Inspect LA and LV for thrombus – thoroughly remove any thrombus present
- Check for PFO – PFO should be surgically repaired prior to HVAD® Pump implant

- **Coring**

- After coring, make sure margins of the core are clean and smooth
- Perform visual inspection of cored area and remove any loose tissue and/or clots

- **De-Airing**

- After placement of HVAD® Pump in the LV, passively fill the LV and pump.
- Expose the apex of the heart and shake gently to remove any entrapped air in the heart/ HVAD® Pump.
- Clamp the distal outflow graft. After anastomosis of the outflow graft to the ascending aorta, complete the de-airing process using standard technique.

- **Pump Speed (RPM)**

- Prior to starting the HVAD® Pump, the LV should be full. The pump must always start at 1800 RPM.
- Speed should be increased by no more than 100 RPM at a time.
- Increase the HVAD® Pump speed slowly to avoid suction events. Suction events can lead to the ingestion of tissue/clot from inside the LV, and may also lead to episodes of ectopy.

6.4 Surgical Implant Procedure (continued)

Pump Implantation Preparation

1. After the primary incision is made, open the pericardium to expose and access the left ventricle (LV) apex.
2. When attaching the HVAD® Pump outflow graft, if a thoracotomy approach is used, it may be necessary to perform an additional small thoracic incision.
3. Consider a transesophageal echocardiography (TEE) prior to placing the patient on cardiopulmonary bypass to assess for a patent foramen ovale (PFO). If present, correct the defect prior to HVAD® Pump implantation.
4. Consider flooding the field with CO₂ when appropriate to reduce residual intracardiac air during surgery.

Left Ventricle (LV) Apex Cannulation

1. Expose the LV apex.
2. Select the insertion site for the HVAD® Pump inflow cannula. It should be anterior to the LV apex with the inflow cannula pointing to the mitral valve and parallel to the interventricular septum. Evaluate where the HVAD® Pump will sit when implanted. If it appears it will directly contact adjacent rigid structures, such as the chest wall, consider placing the pump on the diaphragmatic surface, opening the left pleural space, or wrapping it in a sheet of PTFE.



CAUTION: ALWAYS ensure the inflow cannula position is pointed toward the mitral valve and parallel to the interventricular septum to optimize HVAD® Pump operation.

3. Attach the sewing ring to the myocardium using 8-12 pledgeted, double-armed polypropylene sutures. Use felt strips or a felt ring for reinforcement if necessary.



CAUTION: ALWAYS position the sewing ring to permit access to its screw after cannulation.

4. Perform a full-thickness cruciate incision inside the sewing ring using an 11-blade scalpel.
5. Using the apical coring tool (**Figure 111**), create and remove the apical core. To use the apical coring tool:
 - Insert the thumb in the thumb ring and wrap the first two fingers around the handle. Push the ring forward with your thumb, extending the cutting head.
 - After the cutting head is completely extended, place the cutting head through the myocardium. Release tension.
 - Grasp the tool with one hand and use the other to rotate the cutting head as it retracts.
 - Cored tissue is captured within the cutting head.

Figure 111: Apical coring tool

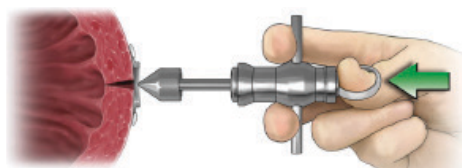

6.4 Surgical Implant Procedure (continued)

Left Ventricle (LV) Apex Cannulation (continued)

NOTE: The sewing ring is packaged at the optimal open diameter to allow for insertion of the inflow cannula. If you make any adjustments, check to be sure the inflow cannula passes easily through the sewing ring. If tight, loosen the screw on the sewing ring to prevent damaging of the O-ring during pump insertion (**Figure 112**).

6. Perform a visual inspection of the left ventricle and remove any thrombus or potential obstruction to the inflow cannula.
7. Place a clamp on the HVAD® Pump outflow graft.
8. Remove the inflow cap from the HVAD® Pump inflow cannula and keep the HVAD® Pump outflow graft cross-clamped.
9. Insert the HVAD® Pump inflow cannula into the ventricle, keeping the cannula perpendicular to the sewing ring (**Figure 113 and 114**), so as not to damage the O-ring on the inflow cannula.
10. Ensure that the HVAD® Pump housing is flush with the sewing ring housing.
11. Use the sewing ring wrench to tighten the sewing ring's screw around the HVAD® Pump inflow conduit (tighten the screw until an audible "click" is heard).



WARNING! DO NOT over-loosen the sewing ring's screw or it may fall off the sewing ring and be lost in the sterile field.

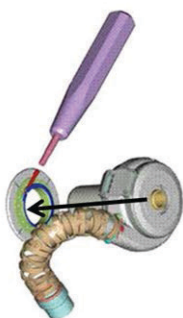

Figure 112: Sewing ring wrench

Pump Insertion into the left ventricle

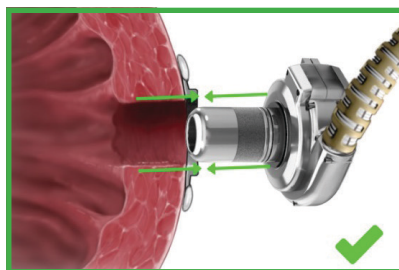

Figure 113 Correct

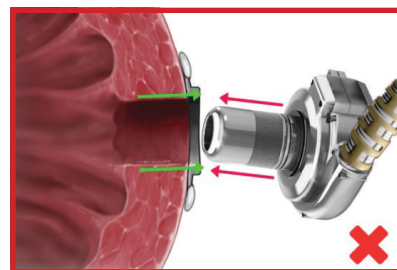

Figure 114: Incorrect

12. Verify no blood or air leakage around the sewing ring. Add reinforced pledgeted sutures as needed. If bleeding or an air leak is observed:
 - a. loosen the sewing ring screw,
 - b. remove the HVAD® Pump,
 - c. and inspect the O-ring on the inflow cannula.
 Replace the HVAD® Pump if the O-ring is damaged.
13. Add reinforced pledgeted sutures as needed.

6.4 Surgical Implant Procedure (continued)

Outflow Graft Anastomosis

1. Gently stretch the outflow graft, measure and cut to length. The outflow graft should lie without kinking or overstretching.
2. Place a partial occlusion clamp on the portion of the ascending aorta where the outflow graft will be placed.
3. Make a longitudinal arteriotomy and sew the outflow graft to the aorta with 4-0 or 5-0 polypropylene (or similar material) sutures.
4. Remove the partial occlusion clamp from the aorta and ensure an intact anastomosis without bleeding, while keeping the HVAD® Pump outflow graft clamped.



WARNING! DO NOT cut the outflow graft too short or too long, or it may kink. Prior to chest closure, ensure that the graft is not kinked or compressed. A kinked or compressed outflow graft may lead to reduced flow and/or thrombus formation.

WARNING! DO NOT immerse the Gelweave™ grafts in saline for longer than 5 minutes. Longer periods of soaking in saline may disrupt the gel matrix, resulting in bleeding.



CAUTION: ALWAYS use round body taper point needles when implanting Gelweave™ prostheses to minimize fiber damage. A kinked or compressed outflow graft may lead to reduced flow and/or thrombus formation.

Driveline Placement

Select the location where the driveline will exit the skin. Consider the position of major organs and structures when determining the path of the tunneler. Massage antibiotic solution into the external surface of the driveline's woven polyester velour.

The tunneler is designed so that the handle can be attached and detached. To attach the handle to the tunneling rod, depress the locking pin, insert the tunneling rod into the handle until it bottoms out, release the locking pin and rotate the handle until the locking pin pops out. Using the tunneler, tunnel the driveline lead to the point of exit. Adjust distance of exit site from costal margin to fit body habitus and prevent rubbing against the costal margin.



WARNING! ALWAYS position the driveline exit site so that the tunneler does not contact any vital organs or structures.

6.4 Surgical Implant Procedure (continued)

Driveline Placement (continued)



CAUTION: The driveline connector is made of nickel-coated brass which may cause a rash in patients with a nickel allergy.

CAUTION: ALWAYS be aware of the position of the driveline to avoid damage by surgical instruments and needles during HVAD® Pump implantation and/or re-operation.

Once the tunneling path has been made, screw the driveline cap on to the tunneling rod tip. Ensure that the two-piece driveline cap has not separated and remains tightly fastened.

Pull the driveline through the tunneling path once it is secured to the tunneling tool.

NOTE: Failure to follow instructions on protecting the driveline connector or improper use of the driveline cap could result in contamination or damage to the connector and electrical fault alarms could occur.

Disconnect the tunneling rod from the driveline cap. Do not remove the driveline cap until it is time to connect the driveline to the controller. Make sure to protect the driveline connector from contamination during this time. Prior to removing the driveline cap, put on clean, dry gloves. To remove the driveline cap, unscrew the outer sleeve and pull back on the grooved part of the connector. Next, place the white, rubber driveline cover over the driveline connector. Verify that the connector is dry and clean before attaching to the controller. If the driveline connector contains any fluid, tissue or foreign material, thoroughly clean it with isopropyl alcohol and dry it with a clean cloth. Attach the driveline to the controller and slide the driveline cover forward to completely cover the controller's silver driveline connector. After the driveline is connected to the controller, the driveline cover is on, and the pump has started, immobilize the driveline at the exit site with retaining sutures.



WARNING! DO NOT grasp the driveline and pull as this may damage the driveline. To remove the driveline cap from the driveline, unscrew the outer sleeve, then pull back on the grooved part of the connector.

De-airing Procedure

1. Start ventilation.
2. Be sure that all IV catheters and pressure monitoring lines are closed to the atmosphere to reduce the possibility of air entering the heart and pump.
3. Reduce cardiopulmonary bypass flow to allow filling of the left ventricle and pump.
4. Place a sterile 19-gauge needle into the outflow graft between the HVAD® Pump and the outflow graft clamp.

6.4 Surgical Implant Procedure (continued)

De-airing Procedure (continued)



CAUTION: ALWAYS use the smallest possible needle for de-airing; 19-gauge is normally sufficient. Hypodermic needles have a cutting point which may result in blood leakage and may require repair by suturing.

5. Start HVAD® Pump at 1800 RPM by pressing the blue button labeled "START" on the monitor.
6. With the HVAD® Pump at 1800 RPM, use TEE to assess air in the left ventricle and aorta.



WARNING! ALWAYS remove all air from the HVAD® Pump and its conduits to reduce risk of air embolus.

WARNING! DO NOT de-air the HVAD® Pump when there is inadequate blood volume in the HVAD® Pump or leaks in the inflow/outflow connections, as air may enter the HVAD® Pump and outflow graft resulting in a delay in de-airing and possible air embolism.



CAUTION: DO NOT rely on HVAD® Pump flow estimation during the de-airing procedure. Flow estimation may not be accurate.

7. After all air is removed, remove the 19-gauge needle and oversew the needle hole with pledgeted sutures.
8. Release the outflow graft cross clamp.
9. Gradually increase HVAD® Pump speed to achieve the desired flow and wean from cardiopulmonary bypass as tolerated.

NOTE: Increase HVAD® Pump speed in increments of 100 RPM with a 20-second interval between speed changes to gradually increase flow and to help prevent ventricular collapse.

Programming the Back-up Controller to Match the Primary Controller

A back-up controller should always be available and programmed identical to the primary controller. The back-up controller should be programmed before the implant procedure, prior to patient transfer from the operating room, when the primary controller is replaced, and upon any parameter change to the primary controller.

Parameters include:

- | | |
|------------------------------|-----------------------------|
| 1. Pump speed | 6. [Low Flow] alarm limit |
| 2. Hematocrit setting | 7. [High Power] alarm limit |
| 3. VAD ID/Pump serial number | 8. Patient ID |
| 4. Suction Response setting | 9. Lavare™ Cycle |
| 5. Controller date and time | |



For instructions on programming the controller and removing power from the back-up controller, see Section 6.2.

6.5 HVAD® Pump Explant

At Transplant

1. Surgically expose the HVAD® Pump and sewing ring.
2. Place patient on cardiopulmonary bypass according to institutional guidelines.
3. Connect the controller to the monitor and turn off the HVAD® Pump.
4. Cross-clamp two (2) sections of the outflow graft.
5. Cut outflow graft between two (2) clamps.
6. Cut and remove the percutaneous driveline.
7. Remove the HVAD® Pump with the heart.

Myocardial Recovery/ Pump Exchange

1. Surgically expose the HVAD® Pump and sewing ring.
2. Place patient on cardiopulmonary bypass according to institutional guidelines.
3. Connect the controller to the monitor and turn off the HVAD® Pump.
4. Cross-clamp two (2) sections of the outflow graft.
5. Cut outflow graft between two (2) clamps.
6. Cut and remove the percutaneous driveline.



WARNING! At HVAD® Pump explant the percutaneous driveline is not sterile; therefore ensure that the driveline does not contaminate the sterile field.

7. Excise the remaining outflow graft from the aorta and repair the arteriotomy site.
8. Use the sewing ring wrench to loosen the sewing ring screw.
9. Remove the HVAD® Pump.

NOTE: During HVAD® Pump removal for recovery or exchange it may be difficult to withdraw the pump from the left ventricle due to tissue ingrowth on the sintered portion of the inflow cannula. It may be necessary to excise tissue adjacent to the sintering potentially resulting in bleeding and/or air emboli.

10. For pump exchange, refer to “Left Ventricle (LV) Apex Cannulation” in section 6.4, “Surgical Implant Procedure” (starting at step #6). For myocardial recovery, follow the steps below.
11. Repair the hole in the LV.
12. Close sternum and skin incision per routine.
13. Once HVAD® Pump is explanted, rinse gently with NaCL.
14. Place HVAD® Pump in 5% Formaldehyde for at least 2 days.
15. Allow the HVAD® Pump to thoroughly dry.
16. Follow the packaging instructions provided in the Explant Kit (provided by HeartWare) and return the HVAD® Pump in the Explant Kit.

HeartWare, Inc.
Quality Assurance Department
14400 NW 60th Avenue
Miami Lakes, FL 33014 USA

7.0 Patient Management and Education

7.1 Postoperative Management 135

7.1.1 Setting Speed with HVAD® Pump 136

7.1.2 Blood Pressure Maintenance 137

7.1.3 Anticoagulation 137

7.1.4 Right Heart Failure ... 138

7.1.5 Arrhythmias 138

7.1.6 Infection Control Guidelines 138

7.2 Driveline Care 139

7.3 Emergency Management 140

7.4 Physical Rehabilitation 140

7.5 Patient Education 140

7.1 Postoperative Management

After implantation, the patient is returned to the intensive care unit. Fluids are given to maintain pump flow index (pump flow ÷ BSA) at greater than 2.0 L/min/m² with central venous pressure and left atrial pressure less than 20 mmHg. Some vasopressor and/or vasodilatory pharmacologic assistance can be used as required to adjust vasomotor tone. Patients may require inotropic assistance to improve right ventricular function.



WARNING! Data has shown that appropriate patient management can mitigate this risk. The following patient management guidelines should be adopted:

- Monitor and treat mean arterial pressure. Maintain MAP less than 85 mmHg as tolerated.
- Speed on the HVAD® Pump should be set to maintain adequate pump flow index, this generally does not need exceed 2.6 L/min/m². Maintain anticoagulation within the recommended INR range of 2.0-3.0.
- Maintain anticoagulation within the recommended INR range of 2.0-3.0.
- Daily aspirin dose should be > 81 mg and platelet inhibition should be evaluated and adjust ASA monotherapy accordingly or consider combination therapy such as ASA 81 mg plus Aggrenox® (ASA plus extended-release dipyridamole) or daily ASA 81 mg plus Plavix 75 mg.
- Check for ASA resistance with a reliable test (e.g. VerifyNow®) and adjust ASA mono-therapy accordingly or consider combination therapy such as ASA 81 mg plus Aggrenox® (ASA plus extended-release dipyridamole) or daily ASA 81 mg plus Plavix 75 mg. In general, mono-therapy with ASA is not encouraged in the absence of testing for resistance.

7.1 Postoperative Management (continued)

7.1.1 Setting Speed with HVAD® Pump

The pump speed for each patient should be individualized based on body surface area and clinical condition.

Similar to other continuous flow VADs, setting speed appropriately is important to optimize outcomes. The 2013 ISHLT Guidelines (Feldman, et.al., 2013 ISHLT MCS Guidelines. The Journal of Heart and Lung Transplantation, Vol 32, No 2, February 2013) make the following recommendations when setting speed with a continuous flow device:

- Speed should be maintained at a minimum level to: attain satisfactory hemodynamics (MAP \leq 80mmHg, cardiac index $>$ 2.2 L/min/m², end organ perfusion) and optimal decompression of the heart without leftward shift of the intraventricular septum or suction.
- Echocardiography can be helpful when setting speed. It can provide detailed information on right heart function, aortic and mitral valve function, septal positioning and inflow cannula positioning.

One of the operating goals for the HVAD® Pump is to maintain device operation in the “Normal Pulsatility Region” to avoid retrograde flow and suction events. HVAD® Pump flow pulsatility is the difference between the minimum (trough) and maximum flows which are displayed in the flow waveform on the HeartWare® Monitor. Pulsatility is reflected in a positive waveform (similar in form to an arterial line waveform) where the trough value represents the flow during left ventricular diastole and the peak value represents the flow during left ventricular systole (**see figure below**). Pulsatility is affected by a number of patient conditions including left ventricular contractility, right heart function and left ventricular afterload.

The flow waveform trough is the minimum value of the HVAD® Pump flow waveform. The trough value should be $>$ 2.0 L/min and there should be $>$ 2.0 L/min of pulsatility. An example of a flow wave form with a trough of $>$ 2.0 L/min and pulsatility of $>$ 2.0 L/min is shown below.

Figure 115: HVAD® Pump flow waveform

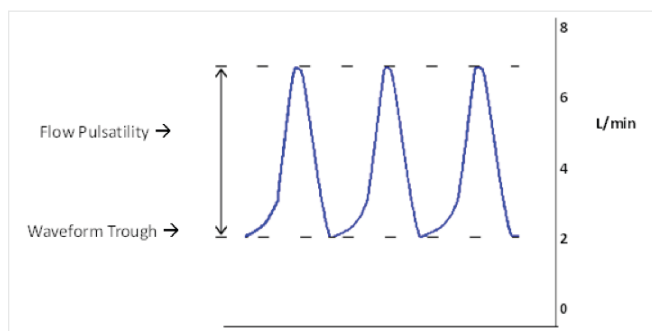
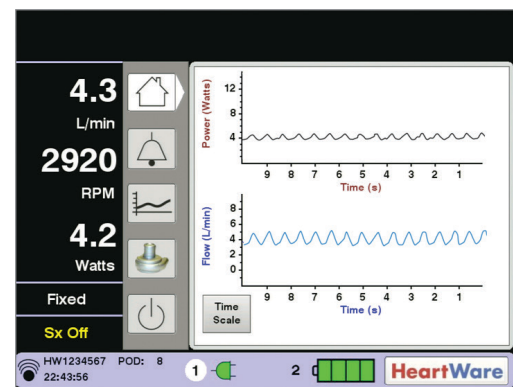

Figure 116: HeartWare® Monitor screen showing HVAD® Pump flow waveform



For more information on HVAD® Pump operational guidelines, see Section 3.3.

NOTE: Recommended HVAD® Pump speeds are between 2400 RPM and 3200 RPM. HVAD® Pump speeds outside this range may result in less than optimal HVAD® Pump operation.

7.1 Postoperative Management (continued)

7.1.2 Blood Pressure Maintenance

Managing blood pressure post continuous flow VAD implant is described in the ISHLT Guidelines. Similar to the ISHLT Recommendations, monitoring of blood pressure following HVAD implant has shown to be very important to optimize patient results, in particular to minimize risk of stroke.

Since the HVAD® Pump provides continuous flow resulting in narrow arterial systolic/diastolic pulse pressure, it is best to monitor the mean arterial pressure (MAP).

Blood pressure should be monitored during both the immediate post-operative period as well as for the duration of support. To monitor blood pressure after the removal of the invasive arterial line utilize either an automated cuff or doppler method.

Blood pressure management goals should be individualized to the patient conditions. The following are recommended bloodpressure management practices:

- Prior to discharge, patients and/or caregivers should be trained to obtain blood pressure readings and record values.
- For patients with a palpable pulse, MAP targets should be ≤ 85 mmHg.
- For patients without a palpable pulse, a manual cuff and a doppler is the preferred method with a MAP target of ≤ 90 mmHg.
- Patients should be provided specific MAP targets for notification of their clinician for possible intervention as part of their discharge instructions.

7.1.3 Anticoagulation

Prior to HVAD® Pump implantation, many patients with refractory heart failure have abnormal coagulation due to abnormal liver function and chronic use of anticoagulation. Prolonged INR can be associated with significant postoperative bleeding. The INR, PTT, and platelet count should be performed prior to HVAD® Pump implantation. The return of each of these parameters to a normal range prior to HVAD® Pump implantation is an important goal.

Anticoagulation should be individualized for each patient. In general, begin low-dose heparin at 10 units/kg/hr on postoperative day one to a target PTT of 40-50 seconds. Prior to initiation of anticoagulation, chest tube drainage should be less than 40 ml/hr for approximately three hours; the HCT should be stable without the need for transfusion of blood products, and coagulation factors approaching normal. Gradually increase the heparin dosage to maintain the aPTT in a range of 50-60 seconds.

The recommended long term oral anticoagulation regimen for the HVAD® Pump is a combination of warfarin and aspirin. In general, aspirin should be started at a dose such as 325 mg/day within 24 hours after implant if there are no postoperative bleeding complications. However, if ASA alone is the medication chosen for anti-platelet therapy, a check for ASA resistance with a reliable test (e.g., VerifyNow®) is recommended to establish the dose or to select an alternative medication. Multi-drug options include:

- ASA 81 mg plus Aggrenox® (ASA (25 mg) plus extended –release dipyridamole (200 mg))
- ASA 81 mg plus clopidogrel 75 mg daily

For patients who are aspirin sensitive or otherwise intolerant, clopidogrel at doses of 75-150 mg/day is a viable alternative. A clopidogrel loading dose of 300 mg followed by 75 mg/day is recommended to reduce the lag time in reaching full therapeutic benefit (typically a 3-4 day lag). Warfarin should be started within 4 days post-op and titrated to maintain an INR of 2.0 to 3.0.

7.1 Postoperative Management (continued)

7.1.4 Right Heart Failure

Right heart failure is common in patients receiving LVADs. Right heart failure usually develops within the first 24 hours after LVAD implant. Warning signs include increasing right atrial pressure (RAP) with concurrent decreases in the pulmonary capillary wedge pressure (PCWP) and LVAD flow. Systemic hypotension, tachycardia and a decrease in urine output soon follow. Volume should be given to increase the RAP to 15-18mmHg. This can be accomplished quickly and easily in the operating room while the patient is on cardiopulmonary bypass. Increasing the RAP to >20mmHg is usually ineffective. After optimizing intravascular volume, increasing inotropic drug support in conjunction with pulmonary vasodilators such as nitric oxide is usually effective. If volume and pharmacological therapy fail, a right ventricular assist device (RVAD) should be considered. Late right heart failure (weeks to months) post LVAD implant is unusual but would manifest itself with similar but less acute symptoms. The etiology of late right heart failure may be a progression of chronic heart disease such as coronary artery disease and/or right ventricular infarction. The cause of the right heart dysfunction should be identified and treated appropriately.

7.1.5 Arrhythmias

The HVAD® Pump functions most effectively when adequate and stable amounts of preload are available. A stable supraventricular rhythm helps to optimize right heart performance and provide the HVAD® Pump with preload. Many heart failure patients will have permanent pacemakers and internal defibrillators in place by the time a VAD is implanted. These devices are often needed in the early postoperative period.

7.1.6 Infection Control Guidelines*

For prevention of infection, remove unnecessary IV lines and replace old IV lines before HVAD® Pump implantation. Administer antimicrobial prophylaxis based on the hospital's nosocomial and microbial sensitivity profile with sufficient coverage for staph aureus, staph epidermidis and enterococcus. Use pre-operative scrub with antiseptic the night before and again the morning of the operation. After HVAD® Pump implantation, continue systemic antimicrobials prophylaxis for 48 to 72 hours. Remove mediastinal and pleural drains as soon as appropriate. Early extubation, removal of monitoring lines, and patient ambulation are encouraged. Rapid restoration of oral nutrition should be attempted using tube feeding if necessary. Turning the patient side to side can start once the patient is clinically stable. Physical therapy and active range of motion can begin on the first postoperative day. The patient can be moved to a chair and can/should use an exercise bicycle or treadmill as soon as possible. Nursing measures to decrease infection include frequent hand washing and strict aseptic technique during contact with invasive lines and during HVAD® Pump dressing changes.

7.2 Driveline Care*

To minimize the risk of infection, driveline exit site dressings should routinely be changed. Routine driveline/exit site care is the responsibility of the patient and the primary caregiver. For proper HVAD® Pump driveline and exit site care, please ensure the following:

1. Use good hand-washing technique before and after dressing changes.
2. Always use aseptic technique.
3. Change dressings per institutional protocol/guidelines.
4. Once the exit site dressing is removed, the driveline should be visually inspected for kinks, tears or other damage. If blood is seen within the lumen of the driveline, the implanting center should be notified immediately.

*Infection Control Guidelines and Driveline Care based on recommendations from "Multicenter Experience: Prevention and Management of Left Ventricular Assist Device Infections". Chinn et al. ASAIO Journal 2005; 51:461–470



CAUTION: ALWAYS examine the driveline for evidence of tears, punctures or breakdown of any of the material during exit site dressing changes. Driveline damage may affect HeartWare™ HVAD™ System performance.

CAUTION: DO NOT expose the driveline to direct or indirect sunlight. ALWAYS keep the driveline completely covered when in the sun. Instruct patients not to use tanning lights or black lights. The light from these sources contains ultraviolet radiation which may damage the outer sheath of the driveline.

5. In general, exit site care is performed every 24-48 hours using an antiseptic cleansing agent, such as a diluted chlorhexidine scrub solution. Following aseptic cleansing, dry the site to avoid tissue injury. Aseptic technique should be followed anytime the dressing is removed and the exit site is exposed, inspected, dressed or handled. When performing exit site care, be sure to wear a cap, mask and sterile gloves.



CAUTION: DO NOT use prophylactic topical antibiotic ointments such as silver sulfadiazine, povidone iodine (betadine), or polymyxin-neomycin-bacitracin ointment on the exit site. These ointments can injure the tissue next to the driveline.

6. Immobilize the driveline with a dressing and stabilize it with a binder or device, such as a foley anchor, Montgomery strap, or a custom-made percutaneous lead immobilization belt. Keep the extra external length of the driveline under a binder or clothing.
7. Complicated, non-routine driveline dressing changes that involve exit site infections may require assistance/supervision from a health care professional.
8. For wounds/incisions other than the driveline exit site that require dressing changes and/or other care, the ability of the patient and caregiver to provide that care will be evaluated by the implanting center. Treatment plans will be dependent upon this evaluation.

7.3 Emergency Management

In the event of an emergency, such as a cardiac arrest, patients with the HeartWare™ HVAD™ System may be defibrillated with either an internal or external defibrillator. The HeartWare™ HVAD™ System can be left on, nothing needs to be turned off or disconnected. If chest compressions are performed, confirm function and positioning of HVAD® Pump once the patient is stable.

Chest compressions may pose a risk due to pump location and position of the outflow graft on the aorta - use clinical judgment. If chest compressions have been administered, confirm function and positioning of HVAD® Pump.



CAUTION: Chest compressions may pose a risk due to pump location and position of the outflow graft on the aorta - use clinical judgment. If chest compressions have been administered, confirm function and positioning of HVAD® Pump.

7.4 Physical Rehabilitation

Physical Rehabilitation begins as soon as the patient admitted to the intensive care unit is stable. Early extubation, removal of monitoring lines, and patient ambulation are encouraged. Turning the patient from side to side should start once the patient is clinically stable. Physical therapy and active range of motion may begin on the first postoperative day. The patient may be moved to a chair and should use a bed bike, exercise bicycle or treadmill as soon as possible. Within a few days of VAD implant, the patient should be ambulating in the halls and performing mild exercise under the supervision of a physical therapist. The nursing, physical therapy, and occupational therapy staff will work together to prepare the patient for hospital discharge - whether to home or a rehabilitation facility. If discharged to home, at the clinician's discretion, the patient may attend a structured outpatient cardiac rehabilitation program.

7.5 Patient Education

Patient training is critical to ensure safe and successful outcomes. The patient must be able to demonstrate proficiency in operating the HeartWare™ HVAD™ System and in responding to emergencies. In order to ensure their understanding and ability, patients should be trained using hands-on demonstrations. At the end of the training, the patient should be able to do the following:

- Identify the AC adapter and successfully connect it to the controller and an electrical outlet.
- Identify the power ports on the controller and be able to successfully replace batteries as indicated.
- Successfully recharge batteries with the battery charger.
- Monitor the remaining battery time on each battery according to LED light displays.
- Identify audible and text alarm messages on the controller.
- Understand the meaning of alarms and demonstrate appropriate responses to alarm conditions.
- Successfully switch from one controller to another controller.
- Understand the importance of not pulling, twisting or kinking the driveline or power cables.
- Educate patients and/or caregiver in the importance of blood pressure monitoring and parameters for notifying the clinician.
- Patients should be educated in the importance of having a back-up controller readily available at all times including when changing power sources. Clinicians should emphasize this education in patients who may be at risk of catastrophic cardiovascular collapse if a pump shutdown occurs. Patients at risk include those with a fused aortic valve, an aortic valve that has been sewn shut due to aortic valve regurgitation, or patients with very poor ventricular function.

Following hospital discharge, the patient's understanding of HeartWare™ HVAD™ System operation and alarms should be re-evaluated during routine follow-up visits. This training should include reinforcement of the procedure for switching to a back-up controller in the case of an emergency.

8.0 HeartWare™ HVAD™ System Alarms and Emergencies

8.1 Alarm Overview141

8.2 High Priority Alarms .142

8.3 Medium Priority Alarms144

8.4 Low Priority Alarms...146

8.5 Multiple Alarms.....147







8.6 How to Silence (Mute) Alarms148

8.7 How To Change the Controller.....149

8.1 Alarm Overview

Visual and auditory alarms tell clinicians and patients about the pump, controller, connections, and power supplies (batteries, AC adapter, DC adapter). A quick reference guide for alarms is located in Section 9.0. Alarm conditions are classified as high, medium or low. Each of these alarms has a **1) unique sound, 2) visual display** and **3) message**. See table below.

Table 33: Alarm Conditions: High, Medium, Low

	High	Medium	Low
Controller Display	Flashing Red Triangle 	Flashing Yellow Triangle 	Solid Yellow Triangle 
Controller Audio	<ul style="list-style-type: none"> • Loudest intermittent beep • Cannot be silenced by the "Mute" button 	<ul style="list-style-type: none"> • Intermittent beep that becomes louder in 1 and 5 min 	<ul style="list-style-type: none"> • Intermittent beep that becomes louder in 5 and 10 min 
Controller Silencing	<ul style="list-style-type: none"> • Cannot be silenced by the "Mute" button • The alarm will clear once the problem is resolved 	<ul style="list-style-type: none"> • May be silenced for 5 min or 1 hour • Controller and Electrical Faults may be permanently silenced 	<ul style="list-style-type: none"> • May be silenced for 5 min

8.1 Alarm Overview (continued)

When an alarm occurs, two lines of text appear in the Controller Display. The first line describes the alarm and the second line tells you what to do. See example below:

Figure 117: Alarm text display

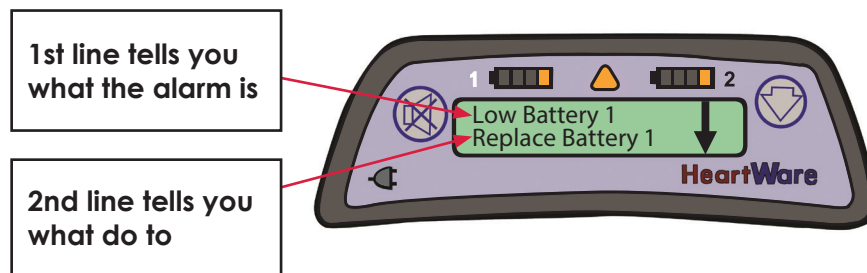

WARNING! ALWAYS check the Controller Display for any information regarding an alarm when using loud machinery or in the vicinity of loud noises as the alarms may not be audible.

8.2 High Priority Alarms

A high alarm is the highest priority and loudest alarm; the Alarm Indicator on the controller is flashing RED and the text message demands immediate action for VAD stoppage, controller malfunction or limited power to run the pump. The monitor will also display alarm information. After the condition is resolved, the audible tone will stop, the alarm message will automatically clear from the controller and VAD parameters will be displayed on screen. See the table below for high alarm messages and possible meaning.

Table 34: High Priority Alarms

Message on Controller (Line 1) (Line 2)	Meaning	Alarm Indicator 	Alarm Sound
no message* no message*	Both power supplies removed - VAD stopped	None*	Continuous
[VAD Stopped] [Connect Driveline]	Driveline disconnected or connector malfunction/broken	Flashing RED	Loud Unable to mute alarm
[VAD Stopped] [Change Controller]	Controller failure		
[Controller Failed] [Change Controller]	Controller failure		
[Critical Battery] [Replace Battery 1]	Limited time remaining on battery connected to Power Source 1		
[Critical Battery] [Replace Battery 2]	Limited time remaining on battery connected to Power Source 2		

8.2 High Priority Alarms (continued)

The Following are High-Priority Alarms:

***[No Power]** (no message): If both power sources are disconnected from the controller, a loud, continuous alarm will sound and there will be NO message on the Controller Display. The HVAD® Pump is NOT pumping and **power sources should be connected immediately**. If this action does not resolve the alarm condition, replace the controller.



WARNING! ALWAYS replace a controller with a blank display or no audible alarms. This condition is predictive of a controller failure.

[VAD Stopped]: The HVAD® Pump will stop if the driveline is disconnected or if the controller fails. The text message indicates whether to connect the driveline or change the controller.

[Controller Failed]: Indicates a potential controller failure and the controller should be exchanged for a new controller. The HVAD® Pump may not be pumping.



For instructions on how to change the controller, see Section 8.7.



WARNING! ALWAYS switch to the back-up controller if there is a [Controller Failed] alarm since the HVAD® Pump may not be running.

[Critical Battery]:

Displayed when there are a few minutes of battery time remaining to power the HVAD® Pump or when the battery has malfunctioned. Replace battery 1 or 2 with a fully charged battery or use the AC adapter or DC adapter.

Displayed if the communication between the controller and battery is interrupted and the second power source is a battery with less than 25% charge capacity remaining. The battery continues to provide power despite the communication interruption. The alarm will clear if:

- non-communicating battery is disconnected,
- communication is restored and/or
- the other battery is replaced with another charged battery ($\geq 25\%$) or power adapter.
(Note: if the other battery is changed to a valid power source, but the non-communicating battery is still connected, the alarm will change to a [Power Disconnect], low priority alarm.)

8.3 Medium Priority Alarms

A Medium Priority Alarm may resolve on its own/without intervention, but patients are instructed to follow the instructions on the screen and call their clinician immediately to receive additional instructions. Once resolved, the alarm message may remain on the Controller Display. Press the “Scroll” button to clear the alarm message from the Controller Display and return to home screen with VAD parameters. A new alarm will also clear a resolved medium alarm from the Controller Display.

The table below describes Medium Alarms and possible meaning.

Table 35: Medium Priority Alarms

Message on Controller (Line 1) (Line 2)	Meaning	Alarm Indicator 	Alarm Sound
[High Watts] [Call]	A change in the status of your HeartWare™ HVAD™ System is detected	Flashing Yellow	<ul style="list-style-type: none"> Gradual increase in volume over the first minute if alarm not muted Alarm gets louder after 5 minutes if alarm not muted Able to mute alarm for 5 minutes or 1 hour Electrical Fault (audio) can be permanently disabled Controller Fault (audio) can be permanently disabled
[Electrical Fault] [Call]			
[Low Flow] [Call]			
[Suction] [Call]			
[Controller Fault] [Call]	Controller malfunction		
[Controller Fault] [Call: ALARMS OFF]	<ol style="list-style-type: none"> Controller malfunction Suction detection, [Low Flow] alarms disabled [High Power] and [VAD Stopped] alarms may be disabled 		

The Following are Medium-Priority Alarms:

[High Watts]: This alarm warns of a high power condition in running the HVAD® Pump. The alarm is triggered when the Watts exceed the [High Power] alarm threshold. This may occur due to thrombus or other materials (e.g. tissue fragments) in the device.

[Electrical Fault]: A fault in the continuity of the pump-to-controller electrical connection triggers this alarm. The fault could be in the HVAD® Pump motor, driveline and connector, or within the controller. The audio portion of this alarm can be permanently disabled via the monitor. When this alarm condition occurs, the HVAD® Pump will be running on a single stator and will consume slightly more power. Do not change controllers during an active [Electrical Fault] alarm. Download controller log files and send to HeartWare for review.

8.3 Medium Priority Alarms (continued)

The Following are Medium-Priority Alarms (continued):

[Low Flow]: The [Low Flow] alarm is triggered if average flow drops below the [Low Flow] alarm threshold.



For additional information about the Alarm Settings Tab, see Section 5.3.

[Suction]: The [Ventricular Suction Detection] alarm is triggered if the suction algorithm has identified a ventricular suction condition. This may self-clear if the suction is transient.



For additional information about the suction algorithm, see Section 3.2.2.

[Controller Fault]: The controller contains two microprocessors - one which controls pump function (PMC) and a second which controls user interface functions (UIC) such as Controller Display and buttons. The [Controller Fault] alarm indicates a possible controller malfunction may have occurred, but during this fault the UIC processor still receives a heartbeat message from the PMC indicating the PMC is still functioning and controlling the pump. The [Controller Fault] Alarm will result in the word [Call] in the Controller Display, notifying the patient to call the clinician. The clinician should query the patient about the frequency and duration of alarm as well as any additional alarms and changes in pump flow, speed or power. The patient should also be asked about any clinical symptoms/changes including dizziness, shortness of breath, angina and/or palpitations. Based on the patient's responses, the following course of action should be taken:

- If there was a single, isolated [Controller Fault] alarm with no change in pump or clinical parameters, instruct the patient to report any additional alarms that may occur. Download the controller log files at the patient's next clinic visit and send to HeartWare for analysis.
- Instruct the patient to return to the center as soon as reasonable (not emergently) so the controller log file can be downloaded and sent to HeartWare for analysis if one of the following situations occurs:
 - If a [Controller Fault] alarm has occurred and been resolved multiple times over a 24 hour period, or
 - If a [Controller Fault] alarm has occurred in conjunction with other alarms even though it has not affected pump flow, power or speed and there are no concurrent clinical symptoms.

8.3 Medium Priority Alarms (continued)

The Following are Medium-Priority Alarms (continued):

The decision to change the controller or what other action is needed will be based on the log file analysis and the patient's clinical condition.

- The patient should be instructed to change the controller and return to the implanting center as soon as is reasonable (within 12-16 hours) if one of the following occurs:
 - The [Controller Fault] alarm is occurring frequently (more than 1 time per hour), with increasing frequency,
 - If the [Controller Fault] alarm has occurred and not resolved,
 - If the [Controller Fault] alarm has occurred in conjunction with other alarms, and is associated with a change in pump flow, speed or power or any adverse clinical symptom such as light headedness or shortness of breath.
 - Download the log files from the original controller and the current controller and send them to HeartWare for analysis.

The [Controller Fault] alarm audio can be permanently silenced but this cannot be done by the patient. It requires the monitor.



For additional information on the Alarm Settings Tab, see Section 5.3.

8.4 Low Priority Alarms

A low alarm is resolved by following the instructions on the screen. Once resolved, the audible tone will stop, the alarm message will automatically clear from the controller and VAD parameters will be displayed on screen. The table below describes low alarms and possible meaning.

Table 36: Low Priority Alarms

Message on Controller (Line 1) (Line 2)	Meaning	Alarm Indicator 	Alarm Sound
[Low Battery 1] [Replace Battery 1]	Battery 1 is low	Yellow	<ul style="list-style-type: none"> • Alarm gets louder after 5 minutes and even louder after 10 minutes, if alarm not muted. • Able to mute alarm for 5 minutes. Press "Alarm Mute" button.
[Low Battery 2] [Replace Battery 2]	Battery 2 is low		
[Power Disconnect] [Reconnect Power 1]	Power Source 1 disconnected or defective		
[Power Disconnect] [Reconnect Power 2]	Power Source 2 disconnected or defective		

8.4 Low Priority Alarms (continued)

The Following are Low-Priority Alarms:

[Low Battery]: This alarm is triggered when both batteries have a remaining capacity < 25% and/ or if one battery has < 25% when the other power source is the AC or DC adapter.

[Power Disconnect]: This alarm is triggered if:

- a controller power source is disconnected or defective.
- the communication between the controller and battery is interrupted and the second power source is a battery with $\geq 25\%$ charge capacity remaining. The battery continues to provide power despite the communication interruption.

The alarm will clear if communication is restored and/or the power supply should be replaced immediately because the patient will be without a back-up power source.



WARNING! ALWAYS respond to low battery alarms. Silencing an alarm does not resolve the alarm condition and will eventually deplete the batteries.

WARNING! NEVER disconnect both power sources (batteries and AC or DC adapter) at the same time since this will stop the pump. At least one power source must be connected at all times.

8.5 Multiple Alarms

It is possible to have concurrent alarm conditions. For multiple alarms, the Alarm Indicator  will display the color of the most severe alarm and the alarm will sound the most severe alarm. An arrow is displayed on the right side of the alarm for multiple alarms (**Figure 118**). Use the “Scroll” button to see all active alarms.

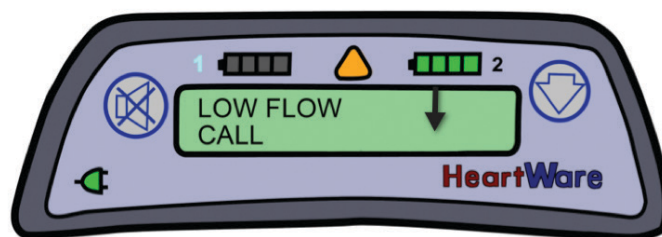



Figure 118: Controller displaying multiple alarms

8.5 Multiple Alarms (continued)

Table 37: Multiple Alarms

Multiple Alarm Condition	Alarm Indicator 	Alarm Sound
More than 2 High Alarms	Flashing RED	Loud, continuous, unable to mute
High and Medium Alarms	Flashing RED	Loud, continuous, unable to mute
High and Low Alarms	Flashing RED	Loud, continuous, unable to mute
More than 2 Medium Alarms	Flashing YELLOW	Gradual increase in volume if alarm NOT muted
Medium and Low Alarms	Flashing YELLOW	Gradual increase in volume if alarm NOT muted
More than 2 Low Alarms	YELLOW	Gradual increase in volume if alarm NOT muted

NOTE: If an arrow is displayed on the right side of the alarm message, there are multiple active alarms. Use the "Scroll" button to see all alarm conditions. Press the "Scroll" button to advance to the next alarm or to the pump parameters (flow, speed and power). If the "Scroll" button is not touched for 1 minute, the controller automatically displays the most severe alarm on the Controller Display. If a new alarm occurs, the Controller Display will show the new alarm.

8.6 How to Silence (Mute) Alarms

High alarms CANNOT be silenced. However, medium [Electrical Fault] and low alarms may be silenced for 5 minutes by pressing the "Alarm Mute" button.

Clinicians can also mute medium alarms for one hour by pressing and holding the "Alarm Mute" button, then pressing and holding the "Scroll" button, followed by releasing the "Alarm Mute" button, and finally releasing the "Scroll" button.

The alarm will sound again if a new alarm condition occurs during the mute interval. The medium priority [Electrical Fault] alarm and [Controller Fault] alarm can be permanently disabled by accessing the Alarm Settings in the monitor's System Screen.



For additional information about the Alarm Settings Tab, see Section 5.3.



WARNING! ALWAYS investigate, and if possible, correct the cause of any alarm. Silencing an alarm does not resolve the alarm condition.

8.6 How to Silence (Mute) Alarms (continued)

Status Message Display

The monitor may display a status message where alarms are typically displayed. The following are potential status messages:

Table 38: Status Message Display

Message	Potential Causes
VAD Off	Driveline connected to controller and HVAD® Pump manually stopped
Data @ Limit	Patient data cannot be stored due to maximum number of patients or lack of storage space

NOTE: The monitor will overwrite files at its data limit which is based on the amount of hard disc space used. The USB flash drive can be used to transfer log files.



For additional information on alarm display on the monitor, see Section 5.2.

8.7 How to Change the Controller

A back-up controller and fully charged batteries must be available at all times for controller failures or malfunctions. The back-up controller should be set with the same pump parameters and patient information as the primary controller.

NOTE: Patients with a fused aortic valve, an aortic valve that has been sewn shut due to aortic valve regurgitation, or patients with very poor ventricular function should be educated in the importance of having a back-up controller readily available at all times including when changing power sources.

A controller failure or serious controller malfunction will generate a high priority or RED alarm and the Controller Display will tell you if you should “Change Controller”.

VAD Stopped
Change Controller

Controller Failed
Change Controller

8.7 How to Change the Controller (continued)

Steps to Change the Controller:

1. Have patient sit or lie down and place the new controller within easy reach.

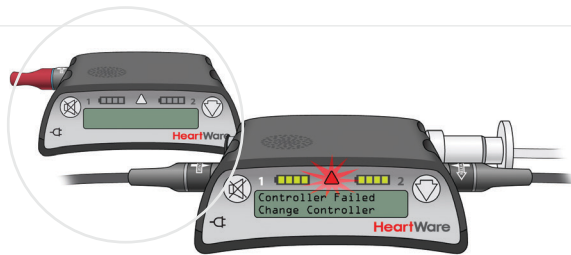

Figure 119

2. Connect one POWER source to the new controller.

NOTE: The new controller may alarm after 10 seconds with a [VAD Stopped, Connect Driveline] high alarm. This is expected behavior.

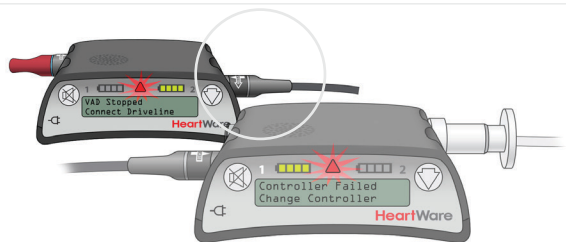

Figure 120

3. Disconnect the driveline from the original controller and connect the driveline to the new controller. This should restart your PUMP.
 - Verify that the pump is working. The RPM, L/min and Watts numbers should show on Controller Display. If your pump does not restart, re-check driveline and power source connections. If it still doesn't start, call for medical assistance immediately.
 - If you have only connected 1 power source to the new controller, you will also have a [Power Disconnect, Reconnect Power] alarm.

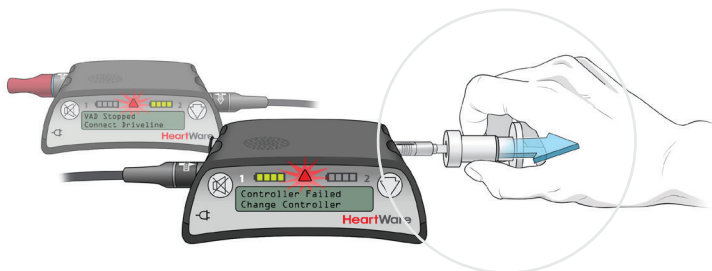

Figure 121

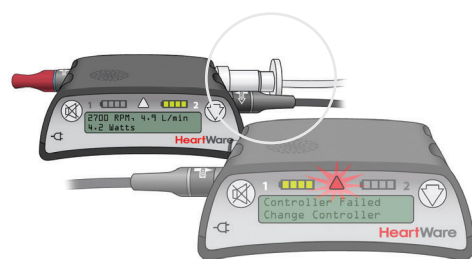

Figure 122

8.7 How to Change the Controller (continued)

Steps to Change the Controller (continued):

4. "PREVENT" the [No Power] alarm from sounding on the original controller. This needs to be done before removing all power. There are 2 options, see below:
 - **If a red alarm adapter is available**, insert it into the data connector on the original controller.
 - **If no alarm adapter is available:**
 - Press and hold the "Alarm Mute" and "Scroll" buttons on the original controller until a "beep" is heard, or for at least 5 seconds.
 - Release the "Alarm Mute" and "Scroll" buttons.
 - You can now remove all power from the original controller and no alarm should sound.
 - **If you removed power before silencing the [No Power] alarm, reconnect a power source and follow the steps above to silence it.**

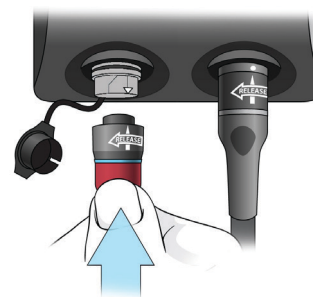

Figure 123

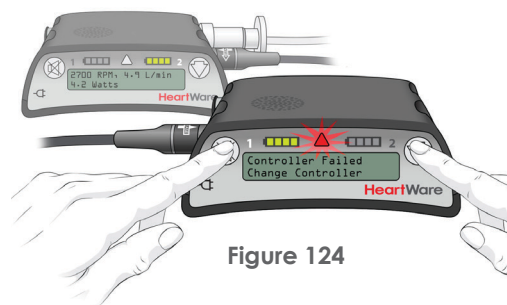

Figure 124

NOTE: If the [No Power] alarm is not disabled prior to removing both power sources, the controller alarm may sound for up to 2 hours.

5. Connect a second POWER source to the new controller.

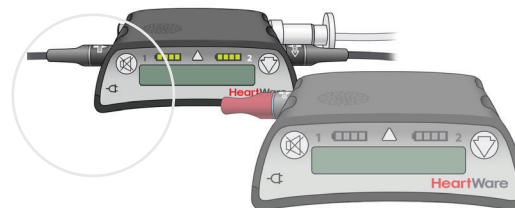

Figure 125

6. Be sure the driveline cover is over the silver driveline connector and the data port is covered by the cap. If the red alarm adapter is connected to the controller that is now running the pump, remove it and close the cap on the data port.

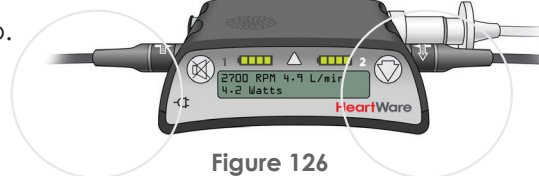

Figure 126

7. Remove the original controller from service and provide a new back-up controller to the patient.

8.7 How to Change the Controller (continued)

When doing a controller exchange, the priority is to restart the pump quickly. It may be helpful to remember the 4 P's:

1. **POWER...** Connect a power source to your back up controller.
2. **PUMP..** Restart the pump by connecting the driveline to the new controller.
3. **PREVENT....** Prevent the [No Power] alarm on the original controller with the red alarm adapter or pressing the "Scroll" and "Alarm Mute" buttons at the same time.
4. **POWER...** Connect a second power source to the new controller.



WARNING! ALWAYS keep a spare controller and fully-charged spare batteries available at all times in case of an emergency.



WARNING! DO NOT attach the alarm adapter to a controller that is connected to a running pump. The alarm adapter silences the [No Power] alarm and should only be attached to a controller that has failed or malfunctioned and is no longer connected to a pump.



For additional information on making good connections, see Sections 4.1.

For additional information on alarms, see Sections 8.1.

9.0 Quick Reference Guide for Alarms

Alarm Type: High (Critical)					
Alarm Symbol	Alarm Tone	LCD Display Line 1	LCD Display Line 2	Potential Causes	Potential Actions
None 	<ul style="list-style-type: none"> Continuous loud Unable to mute 	(no message)	(no message)	<ul style="list-style-type: none"> No power to pump Pump has stopped 	<ul style="list-style-type: none"> Connect two new power sources Replace controller Contact HeartWare Clinical Support
Flashing Red 	<ul style="list-style-type: none"> Loud, Two-toned alarm Unable to mute 	[VAD Stopped]	[Connect Driveline]	<ul style="list-style-type: none"> Driveline disconnected Driveline fracture Connector malfunction/breakage VAD electrical failure 	<ul style="list-style-type: none"> Reconnect driveline Contact HeartWare Clinical Support Download/email patient log files
		[VAD Stopped]	[Change Controller]	<ul style="list-style-type: none"> Controller failure VAD failure Thrombus or other materials (e.g., tissue fragments) in the device 	<ul style="list-style-type: none"> Exchange controller Contact HeartWare Clinical Support Download/email patient log files
		[Controller Failed]	[Change Controller]	<ul style="list-style-type: none"> Controller component failed 	<ul style="list-style-type: none"> Exchange controller Contact HeartWare Clinical Support
		[Critical Battery]	[Replace Battery 1]	<ul style="list-style-type: none"> Limited time remaining on battery connected to Power Source 1 or 2 Battery malfunction 	<ul style="list-style-type: none"> Replace critical battery with fully charged battery or the AC or DC adapter Change controller if new power sources do not correct alarm
		[Critical Battery]	[Replace Battery 2]		

9.0 Quick Reference Guide for Alarms (continued)

Alarm Type: Medium					
Alarm Symbol	Alarm Tone	LCD Display Line 1	LCD Display Line 2	Potential Causes	Potential Actions
Flashing Yellow 	Intermittent beep <ul style="list-style-type: none"> Gradual increase in alarm volume over time if not muted Able to mute alarm for 5 minutes or 1 hour Electrical Fault (audio) and Controller Fault (audio) can be permanently disabled Press the "Scroll" button on the controller to clear resolved medium alarm messages 	[Controller Fault]	[Call]	<ul style="list-style-type: none"> Controller component malfunction but pump still working 	<ul style="list-style-type: none"> Confirm frequency and duration of alarm, concurrent alarms, and pump flow/speed/power Assess patient for complaints of shortness of breath, chest pain, palpitations, dizziness, etc. Isolated alarm should be monitored with download at next visit
		[Controller Fault]	[Call: ALARMS OFF]	<ul style="list-style-type: none"> Controller component malfunction Suction Detection disabled [Low Flow] alarm disabled [VAD Stopped] alarm may be disabled [High Power] alarm may be disabled 	<ul style="list-style-type: none"> Multiple alarms within 24 hours without other issues will be assessed at non-emergent visit Multiple alarms within 1 hour with other alarms or symptoms, replace controller and assess in emergent visit Download/email patient log files from original (alarming) controller and new controller Contact HeartWare Clinical Support
		[High Watts]	[Call]	<ul style="list-style-type: none"> HVAD® Pump Watts have exceeded [High Power] alarm threshold Alarm threshold set too close to average power Thrombus or other materials (e.g., tissue fragments) in the device High RPM High flow VAD electrical fault 	<ul style="list-style-type: none"> Confirm correct settings for [High Power] alarm and pump speed Consider checking blood coagulation labs Assess patient for hemolysis Download/email patient logs files Check for aortic insufficiency, thrombus, etc. Contact HeartWare Clinical Support

9.0 Quick Reference Guide for Alarms (continued)

Alarm Type: Medium					
Alarm Symbol	Alarm Tone	LCD Display Line 1	LCD Display Line 2	Potential Causes	Potential Actions
Flashing Yellow 	Intermittent beep <ul style="list-style-type: none"> Gradual increase in alarm volume over time if not muted Able to mute alarm for 5 minutes or 1 hour Electrical Fault (audio) and Controller Fault (audio) can be permanently disabled Press the "Scroll" button on the controller to clear resolved medium alarm messages 	[Electrical Fault]	[Call]	<ul style="list-style-type: none"> Fault in continuity of pump-to-controller electrical connections Partial driveline fracture Connector malfunction Controller component failure VAD malfunction 	<ul style="list-style-type: none"> Check driveline cover and ensure driveline connector is engaged Inspect driveline for defects Download/email patient log files Contact HeartWare Clinical Support
		[Low Flow]	[Call]	<ul style="list-style-type: none"> Average flow below [Low Flow] alarm threshold Alarm threshold set too close to average flow Suction RPM too high or too low Poor VAD filling (right ventricular failure, hypovolemia, tamponade, arrhythmias, inflow cannula obstruction, etc.) High blood pressure Outflow graft kink 	<ul style="list-style-type: none"> Confirm VAD parameters If possible, confirm correct settings for [Low Flow] alarm limit and viscosity Confirm blood pressure (MAP < 85 mmHg) Evaluate cause of poor left ventricle filling (include attaching patient to monitor to evaluate pump wave form) and consider volume resuscitation if indicated If no potential patient cause can be identified – download/email patient log files Consider ECHO Contact HeartWare Clinical Support
		[Suction]	[Call]	<ul style="list-style-type: none"> RPM too high Poor VAD filling (right ventricular failure, hypovolemia, tamponade, arrhythmias, inflow cannula obstruction, etc.) Thrombus or other materials (e.g., tissue fragments) in the device 	<ul style="list-style-type: none"> Confirm pump flow trends to evaluate a decrease in mean flow Download/email patient log files Consider volume resuscitation and/or correct cause of poor left ventricle filling Consider decreasing pump speed Contact HeartWare Clinical Support Consider ECHO

Alarm Type: Low					
Alarm Symbol	Alarm Tone	LCD Display Line 1	LCD Display Line 2	Potential Causes	Potential Actions
Solid Yellow 	<ul style="list-style-type: none"> Intermittent beep-gradual increase in alarm volume over time if not muted Able to mute alarm for 5 minutes. 	[Low Battery 1]	[Replace Battery 1]	<ul style="list-style-type: none"> Battery power is low 	<ul style="list-style-type: none"> Replace low battery
		[Low Battery 2]	[Replace Battery 2]		
		[Power Disconnect]	[Reconnect Power 1]	<ul style="list-style-type: none"> Power source is disconnected or malfunctioning 	<ul style="list-style-type: none"> Reconnect power source Replace power source Replace controller
		[Power Disconnect]	[Reconnect Power 2]		

+ 10.0 Appendix

Appendix A:
System Components..... **157**

Appendix B:
Product Specifications **158**

Appendix C:
EMC Manual Requirements
Guidance Document..... **160**

Appendix D:
Symbol Definitions..... **164**

Appendix A: System Components

Implantables (Supplied Sterile - ETO)

- HVAD® Pump
- 10mm gel impregnated polyester graft
- Sewing Ring
- Strain Relief

Surgical Tools and Accessories (Supplied Sterile - ETO)

- Tunneler Rod and Handle
- Sewing Ring Torque Wrench
- Coring Tool
- Driveline Extension Cable
- Driveline Cap
- Hex Driver
- Inflow Cap
- Driveline Cover

Externals (Supplied Non-Sterile)

- Controller (includes AC Adapter/Power Cord*, Alarm Adapter*)
- Controller DC Adapter
- **Carrying Case (Shoulder Pack, Waist Pack or Patient Pack)**
- Shower Bag
- Monitor with Display Case (includes AC Adapter/Power Cord*, Data Cable*)
- Battery Charger (includes Power Cord)
- Battery
- USB Flash Drive
- Explant Kit

Instructions for Use (IFU)

*Also available as individual item

Appendix B: Product Specifications

Essential Performance

The HVAD® Pump runs with adequate flow

Pump

Mass (or weight)	160 g
Volume	50 cc
Materials	Titanium, Titanium Nitride, PEEK® and ceramic

Outflow Graft

Length	60 cm
Diameter (or size)	10 mm
Materials	Gelatin sealed polyester

Strain Relief

Material	PEEK®, titanium
----------	-----------------

Driveline

Length	119 cm
Diameter	4.8 mm
Materials	ETFE (Ethylene tetrafluoroethylene) PTFE coated MP35N DFT wire in a silicone inner sleeve with a polyurethane outer sleeve along with a polyester sleeve

Sewing Ring

Materials	Titanium, polyester
-----------	---------------------

Controller

Weight	0.5 kg
Dimensions	13.4 x 10.5 x 5.1 cm
Material	Plastic (ABS)
Display	Main screen, battery Levels 1 & 2
Messages	Status and 3 alarm priorities
Buttons	Alarm Mute, Scroll Arrow

Battery

Type	Li Ion, rechargeable
Weight	0.5 kg
Dimensions	9.9 x 8.9 x 4.6 cm
Indicators	Battery level LED
Ratings	14.8 V, 51.8 Wh or 14.4 V, 63.4 Wh (see battery label)

Battery Charger

Capacity	4 batteries
Recharge Time	5 hours, fully depleted
Weight	1.3 kg
Dimensions	28.6 x 13.4 x 10.2 cm
Electrical Ratings	100-240 V, 50-60 Hz, 75 VA input; 17 V, 4 A output

Controller AC Adapter

Weight	0.7 kg
Dimensions	12.1 x 7.5 x 5.1 cm
Electrical Ratings	100-240 V, 50-60 Hz, 140 VA input; 15 V, 3.3 A output

Controller DC Adapter

Weight	0.7 kg
Dimensions	12.1 x 7.5 x 5.1 cm
Electrical Ratings	12-15.6 V, 7 A input; 15 V, 3.3 A output

Appendix B: Product Specifications (continued)

Monitor	REF1510	REF1520 or REF1521
Type	Notebook with touch screen Input	
Operating System	QNX	QNX
Weight	2.5 kg	3.0 kg
Dimensions	29.9 x 23.5 x 4.5 cm	28.5 x 21.0 x 4.1 cm (without case) 29.9 x 29.9 x 6.4 cm (with case)
Electrical Ratings	19 V, 3 A maximum input	19 V, 3.4 A maximum input
Monitor AC Adapter		
Weight	0.7 kg	
Dimensions	16.6 x 9.6 x 5.6 cm	
Electrical Ratings	100-240 V, 50-60 Hz, 215 VA input; 19 V, 4.7 A output	

Software Parameters, Ranges & Factory Default Settings

Parameter	Range	Resolution	Factory Default
Pump Speed	1,800 to 4,000 RPM	20 RPM	2,500 RPM
[Low Flow] alarm	1.0 to 9.9 L/min	0.1 L/min	1.0 L/min
[High Power] alarm Limit	1.0 to 25.0 Watts	0.5 Watts	16.0 Watts
Suction Detection	Off, Alarm	N/A	Off
Hematocrit	20-50% HCT	1%	30%
Data Logging	15 Minutes	N/A	15 Minutes
Lavare™ Cycle	Off, On	N/A	Off

NOTE: All dimensions are given as length x width x height. PEEK is a registered trademark of Victrex plc.

IEC 60601-1 Classifications

Type of protection against electric shock:

- Controller AC adapter – Class II
- Controller DC adapter – Class II
- Controller – Class II, Internally Powered
- Battery charger – Class I
- Monitor AC adapter – Class I

Degree of protection against electric shock:

- Type CF Defibrillation-Proof Applied Parts

Degree of protection against the ingress of water:

- IPX7 (controller, battery pack)
- IPX5 (driveline extension cable)
- IPX1 (monitor)
- IP22 (controller AC and DC adapter)
- IPX2 (monitor power adapter, data cable)
- IPX0 (battery charger)

Recommended environmental conditions

Component	Temperature Range	Relative Humidity	Atmospheric Pressure
Controller	Operating: -20 to +50°C (-4 to +122°F)	Operating: 15% - 95%	Operating: 700 -1060 hPa
	Storage and Transport: -20 to +50°C (-4 to +122°F)	Storage and Transport: 10% - 93%	Storage and Transport: 500 -1060 hPa
Controller AC and DC Adapter	Operating: -20 to +50°C (-4 to +122°F)	Operating: 15% - 95%	Operating: 700 -1060 hPa
	Storage and Transport: -40 to +70°C (-40 to +158°F)	Storage and Transport: 10% - 93%	Storage and Transport: 500 -1060 hPa
Battery	Operating: +10 to +40°C (+50 to +104°F)	Operating: 15% - 95%	Operating: 700 -1060 hPa
	Storage and Transport: -20 to +25°C (-4 to +77°F)	Storage and Transport: 10% - 93%	Storage and Transport: 500 -1060 hPa

Appendix B: Product Specifications (continued)

Recommended environmental conditions (continued)

Component	Temperature Range	Relative Humidity	Atmospheric Pressure
Battery Charger	Operating: +10 to +40°C (+50 to +104°F)	Operating: 30% - 75%	Operating: 700 -1060 hPa
	Storage and Transport: -40 to +70°C (-40 to +158°F)	Storage and Transport: 10% - 93%	Storage and Transport: 500 -1060 hPa
Monitor and Monitor AC Adapter	Operating: +5 to +40°C (+41 to +104°F) Monitor only; 0 to +40°C (+32 to +104°F) Monitor AC Adapter only	Operating: 15% - 95%	Operating: 700 -1060 hPa
	Storage and Transport: -40 to +70°C (-40 to +158°F)	Storage and Transport: 10% - 90%	Storage and Transport: 500 -1060 hPa

Do not store HeartWare equipment in an area exposed to ultraviolet light.
The box label details conditions for transport and storage.
The device label details the environmental condition limits under which the device should be operated.

Appendix C: EMC Manual Requirements Guidance Document

Electromagnetic Compatibility

Medical electrical equipment needs special precautions regarding electromagnetic compatibility (EMC) and needs to be installed and put into service according to the EMC information provided in this user manual.

Portable and mobile radio frequency (RF) communications equipment can affect medical electrical equipment.

Guidance and Manufacturer's Declaration - Electromagnetic Emissions

The HVAD® Pump is indicated for use in the electromagnetic environments specified below. The customer or the user of the HVAD® Pump should assure it is used in such an environment.

RF Emissions CISPR 11	Compliance	Guidance
RF Emissions CISPR 11	Group 1	The HVAD® Pump uses RF energy only for its internal function. Therefore, its RF emissions are very low and are not likely to cause any interference in nearby electronic equipment.
RF Emissions CISPR 11	Class B	The HVAD® Pump is suitable for use in all establishments, including domestic establishments and those directly connected to the public low-voltage power supply network that supplies buildings used for domestic purposes.
Harmonic Emissions IEC 61000-3-2	Complies	
Voltage Fluctuations/ Flicker Emissions IEC 61000-3-3	Complies	
Radiated emissions Avionics RTCA/DO-160F, Section 21	Category M	The HeartWare™ HVAD™ System with 2 battery packs or one battery pack and controller AC adapter is compliant with all related FAA safety requirements and will not interfere with aviation electronics, per Section 21, Category M of the RTCA document number RTCA/DO-160F, as specified in "Use of Portable Electronic Devices Aboard Aircraft" AC number 91.21-1B, Section 8A.

Appendix C: EMC Manual Requirements Guidance Document (continued)

Guidance and Manufacturer's Declaration - Electromagnetic Immunity

The HVAD® Pump is indicated for use in the electromagnetic environments specified below. The customer or the user of the HVAD® Pump should assure it is used in such an environment.

Immunity Test	IEC 60601 Test Level	Compliance Level	Guidance
Electrostatic Discharge IEC 61000- 4-2	± 8 kV Contact ± 15 kV Air	± 8 kV Contact ± 15 kV Air	Refer to Section 4.2 for guidance on minimizing the impact of ESD.
Electrical Fast Transient / Burst IEC 61000-4-4	± 2 kV on Power Supply Lines ± 1 kV on Input/Output Lines	± 2 kV on Power Supply Lines ± 1 kV on Input/Output Lines	Mains power quality should be that of a typical commercial or hospital environment.
Surge IEC 61000-4-5	± 1 kV Differential Mode ± 2 kV Common Mode	± 1 kV Differential Mode ± 2 kV Common Mode	Mains power quality should be that of a typical commercial or hospital environment.
Voltage Dips, Short Interrupts & Variations on power Supply Lines IEC 61000-4-11	< 5% U_T (95% dip in U_T for 0.5 cycles) < 40% U_T (60% dip in U_T for 5 cycles) < 70% U_T (30% dip in U_T for 25 cycles)	< 5% U_T (95% dip in U_T for 0.5 cycles) < 40% U_T (60% dip in U_T for 5 cycles) < 70% U_T (30% dip in U_T for 25 cycles)	Mains power quality should be that of a typical commercial or hospital environment. The HVAD® Pump will always have a battery back-up power supply connected.
NOTE: U_T is the a.c. mains voltage prior to application of the test level			
Power Frequency Magnetic Fields IEC 61000-4-8	30 A/m	30 A/m	Power frequency magnetic fields should be at levels characteristic of a typical location in a typical commercial or hospital environment.

Appendix C: EMC Manual Requirements Guidance Document (continued)

Guidance and Manufacturer's Declaration - Electromagnetic Immunity (continued)

Immunity Test	IEC 60601 Test Level	Compliance Level	Guidance
			Portable and mobile RF communications equipment should be used no closer to any part of the HVAD® Pump, including cables, than the recommended separation distance calculated from the equation applicable to the frequency of the transmitter.
			Recommended separation distance
Conducted RF IEC 61000-4-6	3 Vrms (150 kHz to 80 MHz outside ISM bands ^a)	3 Vrms	$d = 1.2\sqrt{P}$ (outside ISM bands)
	10 Vrms (150 kHz to 80 MHz inside ISM bands ^a)	10 Vrms	$d = 1.2\sqrt{P}$ (within ISM bands)
Radiated RF IEC 61000-4-3	10 V/m (80 MHz to 2.5 GHz)	10 V/m	$d = 1.2\sqrt{P}$ (80 MHz to 800 MHz)
			$d = 2.3\sqrt{P}$ (800 MHz to 2.5 GHz)
			<p>Where P is the maximum output power rating of the transmitter in Watts (W) according to the transmitter manufacturer and d is the recommended separation distance in meters (m).^b</p> <p>Field strengths from fixed RF transmitters, as determined by an electromagnetic site survey, ^c should be less than the compliance level in each frequency range.^d</p> <p>Interference may occur in the vicinity of equipment marked with the following symbol:</p> 

NOTE 1: At 80 MHz and 800 MHz, the higher frequency range applies.

NOTE 2: These guidelines may not apply in all situations. Electromagnetic propagation is affected by absorption and reflection from structures, objects & people.

Appendix C: EMC Manual Requirements Guidance Document (continued)

- ° The ISM (industrial, scientific and medical) bands between 150 kHz and 80 MHz are 6.765 MHz to 6.795 MHz; 13.553 MHz to 13.567 MHz; 26.957 MHz to 27.283 MHz; and 40.66 MHz to 40.70 MHz.
- ° The compliance levels in the ISM frequency bands between 150 kHz and 80 MHz and in the frequency range 80 MHz to 2.5 GHz are intended to decrease the likelihood that mobile/portable communications equipment could cause interference if it is inadvertently brought into patient areas. For this reason, an additional factor of 10/3 is used in calculating the recommended separation distance for transmitters in these frequency ranges.
- ° Field strengths from fixed transmitters, such as base stations for radio (cellular/cordless) telephones and land mobile radios, amateur radio, AM and FM radio broadcast, and TV broadcast cannot be predicted theoretically with accuracy. To assess the electromagnetic environment due to fixed RF transmitters, an electromagnetic site survey should be considered. If the measured field strength in the location in which the HVAD® Pump is used exceeds the applicable RF compliance level above, the HVAD® Pump should be observed to verify normal operation. If abnormal performance is observed, additional measures may be necessary, such as re-orienting or relocating the HVAD® Pump.
- ° Over the frequency range 150 kHz to 80 MHz, field strengths should be less than 10 V/m.

Recommended separation distances between portable and mobile RF communications equipment and the HVAD® Pump

The HVAD® Pump is indicated for use in an electromagnetic environment in which radiated RF disturbances are controlled. The customer or the user of the HVAD® Pump can help prevent electromagnetic interference by maintaining a minimum distance between portable and mobile RF communications equipment (transmitters) and the HVAD® Pump as recommended below, according to the maximum output power of the communications equipment.

Rated maximum output power of transmitter (W)	Separation distance according to frequency of transmitter (m)			
	150kHz to 80MHz outside ISM bands	150kHz to 80MHz within ISM bands	80MHz to 800MHz	800MHz to 2.5GHz
	$d = 1.2\sqrt{P}$	$d = 1.2\sqrt{P}$	$d = 1.2\sqrt{P}$	$d = 2.3\sqrt{P}$
0.01	0.12	0.12	0.12	0.23
0.1	0.38	0.38	0.38	0.73
1	1.2	1.2	1.2	2.3
10	3.8	3.8	3.8	7.3
100	12	12	12	23

For transmitters rated at a maximum output power not listed above, the recommended separation distance d in meters (m) can be estimated using the equation applicable to the frequency of the transmitter, where P is the maximum output power rating of the transmitter in Watts (W) according to the transmitter manufacturer.

NOTE 1: At 80 MHz and 800 MHz, the separation distance for the higher frequency range applies.

NOTE 2: The ISM (industrial, scientific and medical) bands between 150 kHz and 80 MHz are 6.765 MHz to 6.795 MHz; 13.553 MHz to 13.567 MHz; 26.957 MHz to 27.283 MHz; and 40.66 MHz to 40.70 MHz.

NOTE 3: An additional factor of 10/3 is used in calculating the recommended separation distance for transmitters in the ISM frequency bands between 150 kHz and 80 MHz and in the frequency range 80 MHz to 2.5 GHz to decrease the likelihood that mobile/portable communications equipment could cause interference if it is inadvertently brought into patient areas.

NOTE 4: These guidelines may not apply in all situations. Electromagnetic propagation is affected by absorption and reflection from structures, objects, and people.

Appendix D: Symbol Definitions

	Attention, consult accompanying documents
	Follow operating Instructions
	Batch code
	Catalog number
	Serial number
	Class II equipment
IPX0	Keep dry – no water ingress protection
IPX1	Protected against vertically falling water drops
IPX2	Protected against dripping water
IPX5	Protected against water jets
IPX7	Protected against the effects of water immersion
	Defibrillation proof type CF applied part
	Temperature range
	Humidity range
	Date of manufacture

	Manufacturer
	Sterilized with ethylene oxide gas
	Non sterile
	Single use only, do not reuse
	Do not use if damaged
	Properly dispose battery
	Use by YYYY-MM-DD or YYYY-MM
	Direct current power connection
	Monitor connection
	Pump connection
	Input power required
	Output power delivered
	Atmospheric pressure range
	41 CP11/34/SD-2 pin settings
	Diameter

	Not made with natural rubber latex
Rx only	Prescription only symbol
	UL Classification Mark General medical equipment as to electrical shock, fire and mechanical hazards only in accordance with UL60601-1, CAN/CSA C22.2 no. 601.1, ANSI/AAMI ES60601-1 (2005, 3rd ed.), and CAN/CSA-C22.2 no. 60601-1 (2008).
CE	CE Mark
	Authorized representative in the European Community
	The UL mark, product safety certification
	The INMETRO mark, product safety certification
	Usable length
	Non-pyrogenic
	You must consult accompanying documents
	MR unsafe

Tyvek is a registered trademark of E. I. du Pont de Nemours and Company.
Gelweave is a trademark of Vasctek Ltd.

HeartWare Customer Service:

Direct Dial: (305) 364-2500 or (877) 367-4823

Fax: (305) 818-4118

E-mail: cs@heartware.com

Website: www.heartware.com

24-Hour Clinical Support:

Toll free (888) 494-6365 or (888) HW INFO 5

HeartWare®



HeartWare, Inc.
14400 NW 60th Avenue
Miami Lakes, FL 33014 USA
www.heartware.com